

Concrete Pressure Pipe Engineering Manual

Tenth Edition



THOMPSON[™]
PIPE GROUP



CONCRETE PRESSURE PIPE ENGINEERING MANUAL

Tenth Edition

Thompson Pipe Group – Pressure
1003 MacArthur Blvd.
Grand Prairie, Texas 75050
972-262-3600
ThompsonPipeGroup.com
Rev. April 2021

ABOUT THIS MANUAL

With receipt of this book, you have been registered as a holder of the Thompson Pipe Group Engineering Manual. You will receive future amendments and additions. The information in this engineering manual is applicable to the layout and design of concrete pressure pipelines and includes information on various topics. Laying dimensions, structural and design details are given in tabulated form for pipe and fittings. Laying lengths are tabulated for elbows, adapters, outlets, tees, crosses, wyes and reducers. In some cases, laying lengths supplied may vary slightly due to specific job requirements or changes in end type. The layout submittal furnished with each job will confirm any differences. Fittings of special shapes or designs not shown may be furnished. Additional information relating to pipe design, thrust restraint, special applications and installation have been included for general reference. Detailed information and drawings will be sent upon request.

Note: This manual is for information purposes only to our current and future customers, and their consultants. It is intended to serve as a description of the Thompson Pipe Group product line for prestressed concrete cylinder pipe. A conscientious effort has been made to include the most current information known to Thompson Pipe Group at the time of printing.

None of the information should be construed as a representation that any of the products are fit for use in a specific application. Any advice or information appearing regarding the design of specifications for a pipeline system is taken at the reader's risk and Thompson Pipe Group is not liable for any resulting damages. There are no warranties, either expressed or implied, which extend to the information contained or the products described.

For additional product information and how to use them in a specific application, contact a business development manager or the engineering department.

TABLE OF CONTENTS

Section One 1.1	Section Six.....6.1
Introduction to Concrete Pressure Pipe	Outlet Pipe
	• Typical Threaded Outlet
Section Two 2.1	• Access Manhole
Manufacturing	• Typical Centerline Outlet
• Manufacturing Process	• Typical Tangent Outlet
• Special Sections and Fittings	• Reinforcing Band Thickness
• Quality Assurance	
Section Three..... 3.1	Section Seven 7.1
Standard Pipe	Elbows
• Lined Cylinder Pipe	• Rotation of Elbows
• Embedded Cylinder Pipe	• Cylinder Thickness
• Short Pipe	
Section Four..... 4.1	Section Eight.....8.1
Joints	Tees, Wyes, and Crosses
• Standard Joint	• Laying Lengths
• Deep Joint	• Cylinder Thickness
• Snap Ring® Joint	
• Harnessed Clamp Joint	Section Nine..... 9.1
• Testable Joint	Reducers
• Subaqueous Joint	• Laying Lengths
• Bonded Joint	• Cylinder Thickness
• Ball Joint	
• Extra Deep Joint	Section Ten 10.1
• Zinc Metalizing	Adapters
Section Five..... 5.1	• Flange
Bevels and Deflection	• Carnegie Joint
• Bevel Pipe	• Mechanical Joint
• Deflection	• Victaulic
• Horizontal and Vertical Curves	• Bevel Adapter – Deflection Table
• Deflection Tables	
- Deep Joint	Section Eleven 11.1
- Standard Joint	Miscellaneous Fittings
- Full Bevels	• Bulkheads and Night Caps
- Half Bevels	• Wall Pieces
- Extra Deep Joint	• Closures
	• Custom Fittings

Section Twelve.....	12.1	Section Seventeen	17.1
PCCP and BWP Design		Supplemental Protection for	
• Hydraulics		Concrete Pressure Pipe	
• Head Losses Due to Fittings		• Protective Coatings and Linings	
• PCCP Design Guide		• Exterior Barrier Membranes	
Section Thirteen.....	13.1	Section Eighteen	18.1
Thrust Restraint		Layout	
• Small Deflections		• Typical Documents	
• Large Deflections			
• Harness Distance Calculations		Section Nineteen.....	19.1
• Restrained Joints		Suggested Concrete Pipe Specifications	
• Anchor Ring Pipe		• PCCP – Freshwater and Treated	
		Sewage Lines	
Section Fourteen.....	14.1	• PCCP – Sewer Force Main	
Special Concrete Pressure		• PCCP – Gravity Sewer Line	
Pipe Applications		• Option – Intakes and Outfalls	
• Double Wrapped Pipe			
• Heavy Wall Pipe		Section Twenty	20.1
• Buoyancy		Pipeline Services and Emergency Repair	
• Subaqueous Concrete Pipelines		• Welded Joints	
• Pile Supported Pipe		• Repair Saddles	
• Tunneling Installation			
• Treatment Plant Piping		Section Twenty-One.....	21.1
		Appendix	
Section Fifteen.....	15.1	• Standard Abbreviations	
Concrete Pressure Pipe Tapping Systems		• Pipe Orientation	
• Threaded Pressure Taps		• Joint Lubricant and Grout Quantities	
• Strap Type Taps		• Conversion Factors	
• Strapless Taps			
• Flanged Pressure Taps		Section Twenty-Two.....	22.1
		Index	
Section Sixteen.....	16.1	• Detailed Subject Listing	
Pipeline Environment			
• Corrosion Control			



SECTION 1

INTRODUCTION TO CONCRETE PRESSURE PIPE

Through a series of acquisitions, in 2017 Thompson Pipe Group attained the pressure pipe assets of Price Brothers Company (PBC), Gifford-Hill American and Hanson. In 1926 PBC began serving the water works industry with a contract to manufacture and install an 84-inch diameter concrete pressure pipeline.

The early development of prestressed concrete pipe dates to the 1920s when the Lewiston Pipe Company, forerunner of the PBC Pressure Division, experimented with various methods of prestressing. The first successfully prestressed non-cylinder concrete pipe was produced in 1940. That important step was followed two years later by the introduction of the first prestressed concrete cylinder pipe by PBC. During the past 50 years, more than 20 million linear feet of PCCP have been engineered and manufactured by PBC in diameters from 16 to 192 inches.

Concrete provides the pipe with structural strength and rigidity necessary to withstand heavy external loads, as well as a smooth interior wall for optimum flow. The portland cement-rich mortar coating provides protection for the steel components which are the joint rings, cylinder and prestressing wire.

The prestressing wire places the core in compression, enabling it to withstand high internal water pressures and large external loads. Concrete pressure pipe has a high external load-carrying capacity and is normally installed with less stringent bedding and backfill procedures than other pipe materials.



An early installation of prestressed concrete cylinder pipe.



PCCP is ideally suited for many applications, such as this treatment plant. The precise custom fittings made this complex installation simpler to install with no field cutting or tapping.

In total, this engineered combination of concrete and steel results in a pressure pipe design that will withstand high internal pressure and large external loads and will provide excellent corrosion resistance to assure decades of trouble-free performance.

Prestressed concrete cylinder pipe has achieved widespread acceptance within the water and wastewater industry because of its excellent performance, low cost, and design flexibility.

PCCP is used for transmission mains, distribution feeder lines, water intake and discharge lines, pressure siphons, penstocks, industrial pressure lines, cooling water lines, sewer force mains, gravity sewer lines, and subaqueous pipelines.

The pipe is designed in accordance with American Water Works Association (AWWA) Standard C304 for Design of

Prestressed Concrete Pressure Pipe, Steel Cylinder Type for Water and Other Liquids.

Thompson Pipe Group continues to pioneer and advance the technical development of prestressed concrete cylinder pipe for the water works industry.

American Pipe and Construction Company (American), a cement mortar-lined-and-coated steel pipe manufacturer, whose name was later changed to Ameron in 1970, developed a pipe in 1942 with bar reinforcement to supplement the steel cylinder area required to resist the internal hydrostatic pressure. The advantages of this practice, which results in a composite wall structure, were demonstrated through product testing and field experience. Other major milestones:

The City of San Diego was one of the early users of CCP in early 1940s for their water system for pipe diameter up to 42". Other agencies followed suite including the United States Bureau of Reclamation (USBR) in 1949.

American developed its own design and manufacturing guidelines until the first US Federal Specification SS-P-00381 was issued on April 2, 1953. AWWA C303 standard was issued in 1970 and the USBR standard in 1972 and US Federal Specifications SS-P-381B in 1979. The diameter range in the AWWA C303 was extended gradually, through revisions, to 72".

Since introduction of CCP in 1942, Thompson Pipe Group and other pipe manufacturers have manufactured thousands of miles of CCP pipelines in North and South America, the Middle East and Far East.



MANUFACTURING

Thompson Pipe Group manufactures concrete pressure pipe in compliance with our specially developed quality control standards.

The pipe is manufactured in full compliance with applicable American Water Works Association (AWWA) Standards. All pipe produced by Thompson is custom built to meet the specifications and performance criteria of each particular project.

Prestressed Concrete Cylinder Pipe Manufacturing Process

To help explain the basic step-by-step procedure involved in manufacturing our pressure pipe, flow charts are shown below.

Every step in producing prestressed concrete cylinder pipe is done with care and precision.

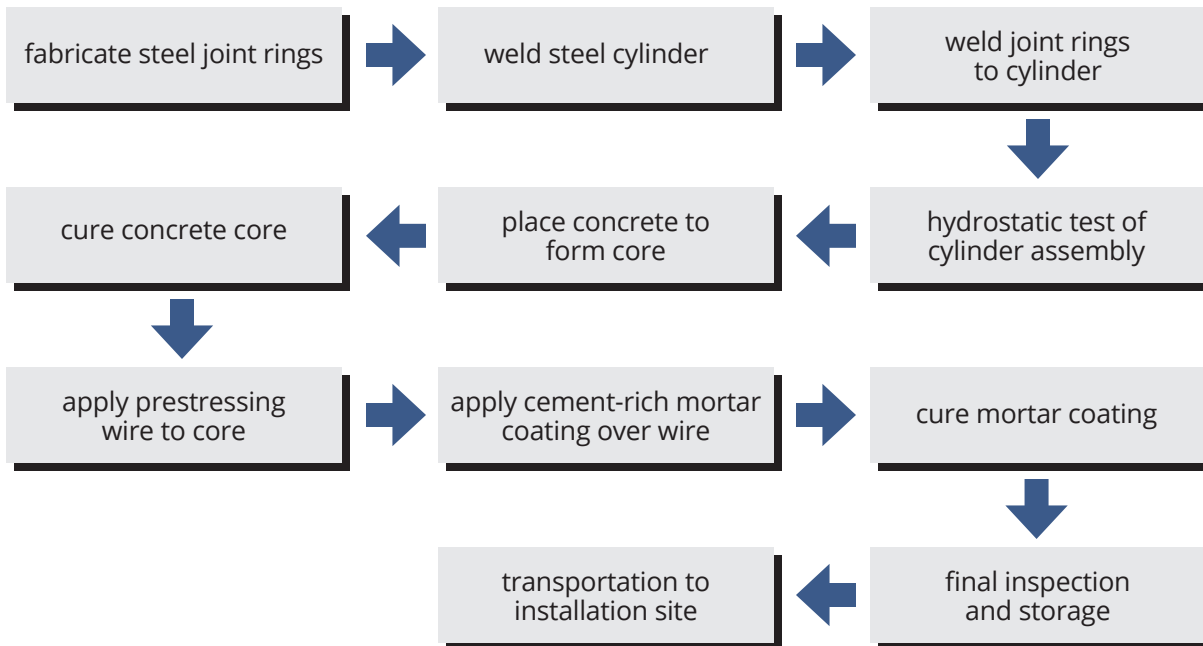

Fabrication of the steel joint rings and forming of the steel cylinder is completed to exact tolerances so they can be welded together to form a watertight membrane.

The steel cylinder, complete with steel joint rings, is then hydrostatically tested to ensure that it is watertight.

When manufacturing lined cylinder pipe (L-301), the next step involves horizontally spinning the steel cylinder as high-strength concrete is centrifugally cast into its inner wall. The centrifugal action forms the concrete into a dense and uniform core.



Concrete is centrifugally cast within the steel cylinder to form the pipe's concrete core.



This newly formed steel cylinder with joint rings welded to each end has just been tested hydrostatically to make certain it is watertight.

When casting larger diameter embedded cylinder pipe (E-301), the steel cylinder is positioned vertically inside a specially designed mold so that it can be embedded within a thick wall of high-strength concrete. During this process, the concrete is poured around the top rim of the vertical mold to form a concrete core on both sides of the steel cylinder. Vibration during the pouring operation assures that the concrete will form a uniformly dense core. Both types of pipe cores are then cured with heat and moisture.

During core placement, concrete test samples are obtained. They are cured along with the pipe and then used for compression testing in the lab. The test samples must meet the compression requirements before the pipe is allowed to proceed to the prestressing stage.

Before the prestressing wire can be used in the manufacturing process, it is tested for ductility, tensile strength, and other physical characteristics. Wire from all sources is tested to ensure it is not susceptible to hydrogen embrittlement as part of the product improvements to prevent recurrence of the 1970s Interpace issues.

The wire is then wrapped under tension around the pipe core. Simultaneously as the wire is wrapped, a portland cement-rich slurry is applied to the surface of the pipe to ensure all steel components are encased. This helically wrapped prestressing wire in combination with the concrete core gives the pipe the capability to accommodate internal pressure and external loads.

During wrapping, the wire's tension is carefully monitored and recorded, and the spacing is continually checked. By varying the spacing of the wire wraps on the pipe, the amount of compression placed in the cylinder and core can be varied. Steel anchor blocks at each end of the pipe maintain the tension in the wire.



The concrete core is placed on the rotating platform of this vertical wrapping machine. Cement slurry is applied as steel prestressing wire is wrapped under tension around the core.



In the coating operation, a slurry of cement and water is sprayed onto the prestressing wire as the mortar is applied over the wire to form a rugged exterior wall that provides protection against corrosion.

The next step is another application of cement slurry immediately followed by a dense, cement-rich mortar coating which encases the steel components to provide protection against corrosion.

After the pipe is coated, it is placed in an enclosure for controlled moisture and temperature curing. This controlled curing ensures that the mortar coating will achieve optimum quality and strength. At this point, the pipe is ready for final inspection. Identification markings are then placed on the pipe's interior.

Bar-Wrapped Concrete Pressure Pipe.

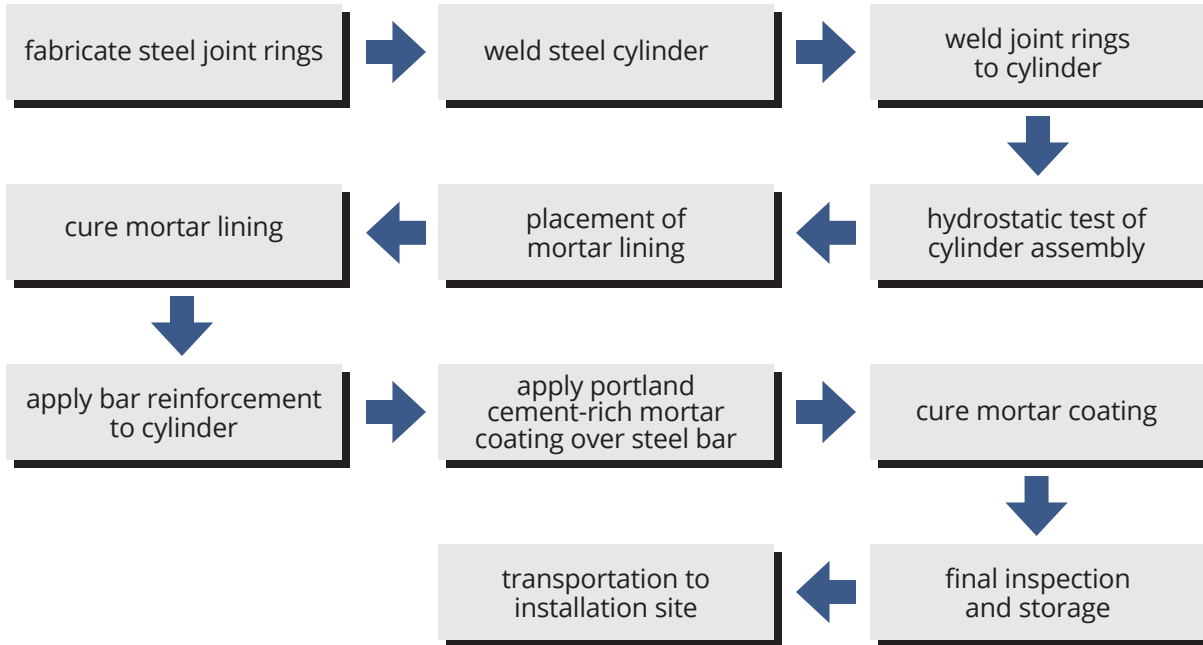

B-303 pipe is comprised of a welded steel cylinder with steel joint rings welded to the ends of the assembly which is then hydrostatically tested to confirm watertightness. The steel cylinder is lined with a $\frac{3}{4}$ " nominal thick centrifugally-placed Portland cement mortar or concrete. This lining is steam-cured to enhance strength gain. A continuous, round reinforcing bar is then wrapped under a moderate tensile stress around the lined steel cylinder before application of a portland cement rich mortar coating. Simultaneously as the wire is wrapped, a portland cement-rich slurry is applied to the surface of the pipe to ensure all steel components are encased. The mortar coating is also steam cured.



A quality control technician checks cylinder steel thickness. Each heat of cylinder steel must also meet ASTM standards referred to in AWWA C301 and C303 for acceptable yield strength.

Special Sections and Fittings

Although most pipeline projects consist largely of straight pipe sections, there will almost always be a number of special pipe and fittings required to complete the job.

These special sections and fittings are designed and custom fabricated to withstand the pressures involved. Each prestressed concrete pressure pipe and bar-wrapped concrete pressure pipe fitting is coated and lined with a mortar coating. To help bond the mortar to the steel plate, wire mesh is welded to each side of the fitting.

Quality Assurance

Thompson Pipe Group places special emphasis on quality assurance. This involves step-by-step attention to precise production procedures and assurance that all machinery and equipment is operating within specified tolerances. Emphasis is made on inspection of every component during each step of the pipe manufacturing process. To further supplement the Quality Assurance Program, Thompson Pipe Group has implemented a computerized Quality Assurance Tracking Program. This system documents the various raw material components that go into each piece of pipe.



Prestressing wire is tested for tensile strength and ductility characteristics.

The prestressing wire is one of the most important structural elements of our prestressed concrete pressure pipe. For this reason, Thompson takes extreme care in its quality control procedures for wire. At each plant, the wire is checked for tensile strength, ductility, internal defects, and for proper wrapping stress when placed around the pipe core.

We also perform quality checks on such things as cement content, absorption, thickness of the mortar lining and coating, and thickness of paint coatings.

Since the early 1940s, our legacy companies have manufactured more than 60 million linear feet of concrete and steel pressure pipe. More than 40,000 man-hours are invested each year to assure the quality of Thompson concrete and steel pressure pipe.



Quality control inspectors monitor wire spacing during prestressing operation. Prestressing wire is tested prior to wrapping and must be within limits specified in ASTM A648 and AWWA C301.



The Thompson Pipe Group team of Quality Assurance inspectors receives extensive training on monitoring in-process and finished pipe quality factors, such as checking roundness of pipe joint rings.



This test specimen of concrete used in the manufacturing of a pipe undergoes a standard concrete compression test. Test specimens are made daily and are cured under the same conditions as the pipe.



SECTION 3

STANDARD PIPE

Two types of prestressed concrete pressure pipe are manufactured by Thompson Pipe Group in accordance with the AWWA C301 standard: lined cylinder pipe and embedded cylinder pipe.

Lined cylinder pipe (L-301) has a concrete core cast inside a steel cylinder that serves as a watertight membrane. The cured concrete core is subsequently wire-wrapped and externally coated with a portland cement-rich mortar.

Embedded cylinder pipe (E-301) has a steel cylinder fully encased in a concrete core which is subsequently wire-wrapped and externally coated with a portland cement-rich mortar.

Thompson Pipe Group also manufactures bar-wrapped concrete pressure pipe (B-303) in accordance with the AWWA C303 standard. A steel cylinder is lined with a centrifugally-placed portland cement mortar. A continuous, round reinforcing bar is then wrapped under a moderate tensile stress around the lined steel cylinder before application of a portland cement-rich mortar coating.

Welded steel pipe is manufactured in accordance with the AWWA C200 Standard. Large diameter steel pipe is fabricated from coils of sheet steel that are helically-formed and continuously welded. The pipes are usually lined with cement mortar by a centrifugal process. After hydrostatic testing, the exterior surfaces are coated with polyurethane or cold-applied tape. Other types of coatings are also available such as mortar coating.

A concrete pressure pipe which incorporates a steel cylinder as well as circumferential and longitudinal reinforcement, designed in accordance with the AWWA C300 standard, can be supplied for direct jacking or other special installation requirements.

The term *standard pipe* refers to straight sections of concrete pressure pipe which are manufactured in nominal laying lengths as shown in the tables. This section contains drawings and data detailing lined cylinder pipe, embedded cylinder pipe, bar-wrapped pipe, and welded steel pipe.

Standard pipe will be manufactured with the bell and spigot shown on the drawings, or where necessary, with various types of special joints on either or both ends. Details of special joints are presented in Section Four of this manual.

SHORT PIPE

A short pipe is any pipe shorter than the standard nominal length. Short pipe sections are used to meet a critical point of intersection, valve, or outlet connection that cannot be accomplished by any other means. Short pipe laying lengths usually range from approximately two feet to two feet less than the nominal laying length. If other lengths are required, contact the pipe manufacturer.

LINED CYLINDER PIPE (L-301) FEATURES

Prestressed concrete lined cylinder pipe (L-301) is designed in accordance with AWWA C304 and manufactured in accordance with AWWA C301.

Concrete structures are prestressed when predetermined compressive stresses are applied to them to counter expected future tensile stresses as a result of field loads.

Prestressing is achieved by helically wrapping, under measured tension and at a uniform spacing, a high tensile strength wire around the concrete-lined steel cylinder. This wire wrap places the steel cylinder and concrete core in compression, developing the pipes' ability to withstand specified hydrostatic pressures and external loads with a safety factor comparable to other waterworks piping materials.

Concrete's high compressive strength and steel's high tensile strength are combined to form an elastic structure. This feature allows the pipe to perform even when design working loads are exceeded.

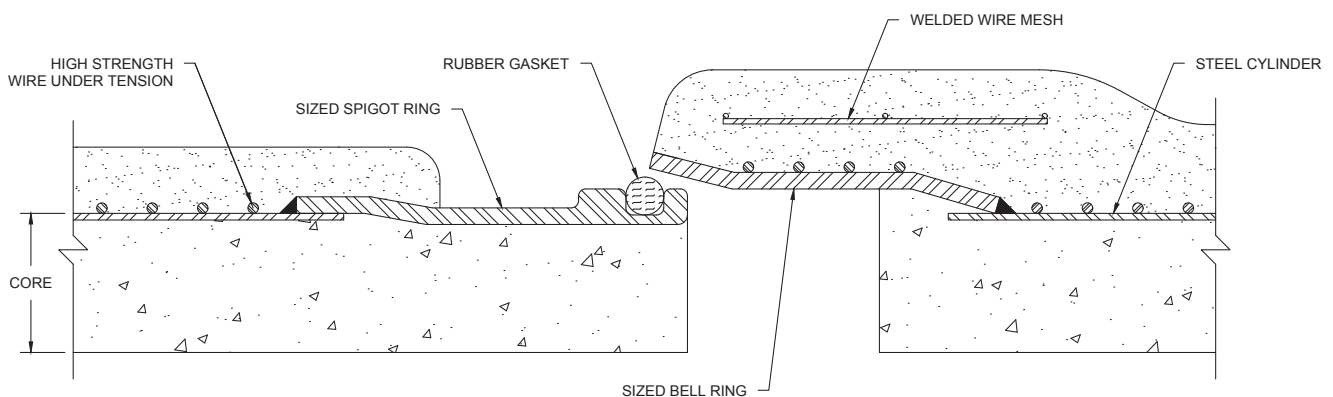

Advantages

Conservative design and rugged construction assures the following benefits:

- ▶ **Long Life**
Cement mortar provides maximum protection from corrosion.
- ▶ **Flexible Joints**
Watertightness is maintained under normal conditions of soil movement.
- ▶ **Strength**
The pipe will withstand normal handling and unplanned concentrated external loadings.
- ▶ **Sustainable High Flow**
Tests on older lines reveal a consistently high carrying capacity with a Hazen-Williams coefficient generally in excess of 140.
- ▶ **Economy of Design**
Each pipe section is designed to meet the requirements of its unique position in the pipeline with an adequate safety factor and no wasteful overdesign.

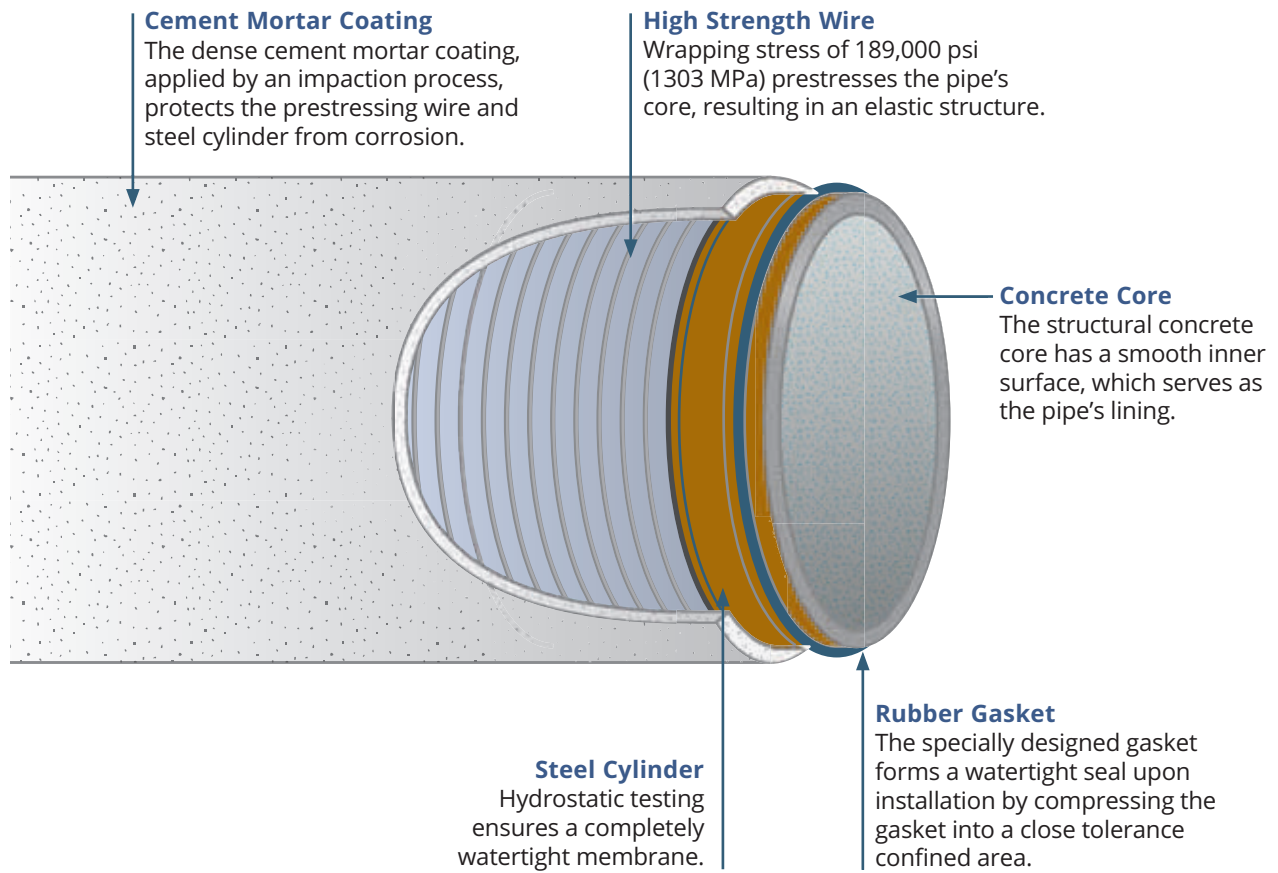

L-301 Standard Dimensions

(For pipe made in Texas)

Pipe Diameter (inches)	Core Thickness (inches)	Joint Depth (inches)	Joint Diameter (inches)	Cylinder Outside Diameter (inches)	Approximate Weight (pounds per linear foot)	Nominal Bell Outside Diameter (inches)	Nominal Barrel Outside Diameter (inches)	Nominal Laying Length (feet)
16	1	4-1/2	18-1/2	18	140	22-1/2	20	20
18	1-1/8	4-1/2	20-3/4	20-1/4	155	24-3/4	22-1/4	24
20	1-1/4	4-1/2	23	22-1/2	185	27	24-1/2	24
24	1-1/2	4-1/2	27-1/2	27	240	31-1/2	29	32
27	1-11/16	4-1/2	30-7/8	30-3/8	290	35	32-1/2	32
30	1-7/8	4-1/2	34-1/4	33-3/4	350	38-1/4	35-3/4	32
33	2-1/16	4-1/2	37-5/8	37-1/8	400	41-3/4	39-1/4	32
36	2-1/4	4-1/2	41	40-1/2	475	45	42-1/2	24
39	1-7/16	4-1/2	44-3/8	43-7/8	520	48-1/2	46	24
42	2-5/8	4-1/2	47-1/4	47-1/4	590	51-1/4	49-1/4	20
45	2-13/16	4-1/2	51-1/8	50-5/8	650	55-1/4	52-3/4	16
48	3	4-1/2	54	54	760	58	56	16

L-301 Standard Dimensions

(For pipe made in Florida and Illinois)

Pipe Diameter (inches)	Core Thickness (inches)	Joint Depth (inches)	Joint Diameter (inches)	Cylinder Outside Diameter (inches)	Approximate Weight (pounds per linear foot)	Nominal Bell Outside Diameter (inches)	Nominal Barrel Outside Diameter (inches)	20
16	1	4-1/2	18-1/2	18	140	22-1/2	20	20
18	1-1/8	4-1/2	20-3/4	20-1/4	155	24-3/4	22-1/4	20
20	1-1/4	4-1/2	23	22-1/2	185	27	24-1/2	20
24	1-1/2	4-1/2	27-1/2	27	240	31-1/2	29	20
30	1-7/8	4-1/2	34-1/4	33-3/4	350	38-1/4	35-3/4	20
36	2-1/4	4-1/2	41	40-1/2	475	45	42-1/2	20
42	2-5/8	4-1/2	47-1/4	47-1/4	590	51-1/4	49-1/4	20
48	3	4-1/2	54	54	760	58	56	20'

EMBEDDED CYLINDER PIPE (E-301) FEATURES

Prestressed concrete embedded cylinder pipe is designed in accordance with AWWA C304 and manufactured in accordance with AWWA C301.

Concrete structures are prestressed when predetermined compressive stresses are applied to them to counter expected future tensile stresses as a result of field loads.

Prestressing is achieved by helically wrapping, under measured tension and at a uniform spacing, a high tensile strength wire around the concrete-lined steel cylinder. This wire wrap places the steel cylinder and concrete core in compression, developing the pipes' ability to withstand specified hydrostatic pressures and external loads with a safety factor comparable to other waterworks piping materials.

Concrete's high compressive strength and steel's high tensile strength are combined to form an elastic structure. This feature allows the pipe to perform even when design working loads are exceeded.

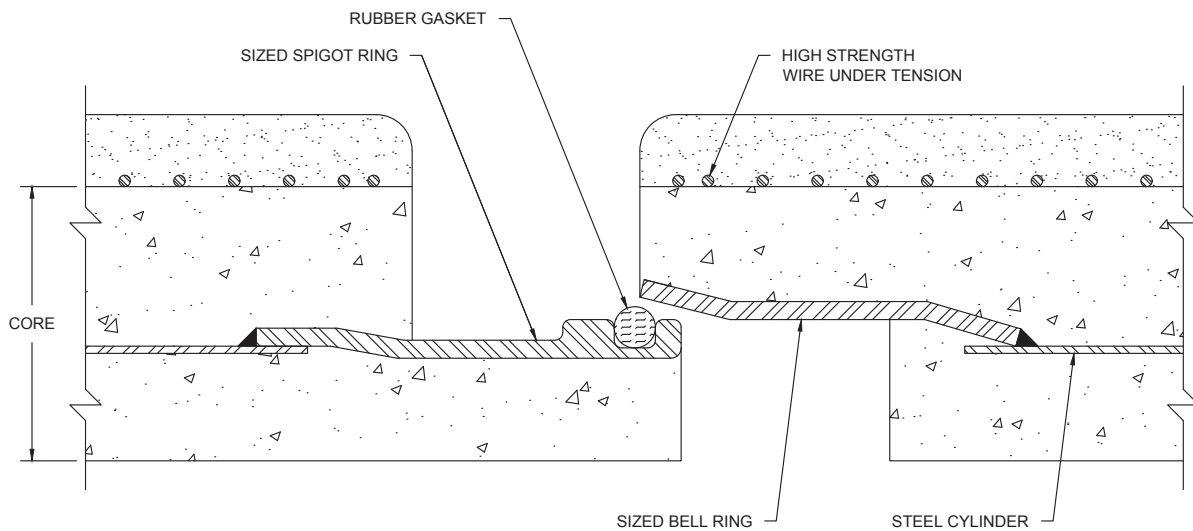

Advantages

Conservative design and rugged construction assures the following benefits:

► Long Life

Cement mortar provides maximum protection from corrosion.

► Flexible Joints

Watertightness is maintained under normal conditions of soil movement.

► Strength

The pipe will withstand normal handling and unplanned concentrated external loadings.

► Sustainable High Flow

Tests on older lines reveal a consistently high carrying capacity with a Hazen-Williams coefficient generally in excess of 140.

► Economy of Design

Each pipe section is designed to meet the requirements of its unique position in the pipeline with an adequate safety factor and no wasteful overdesign.

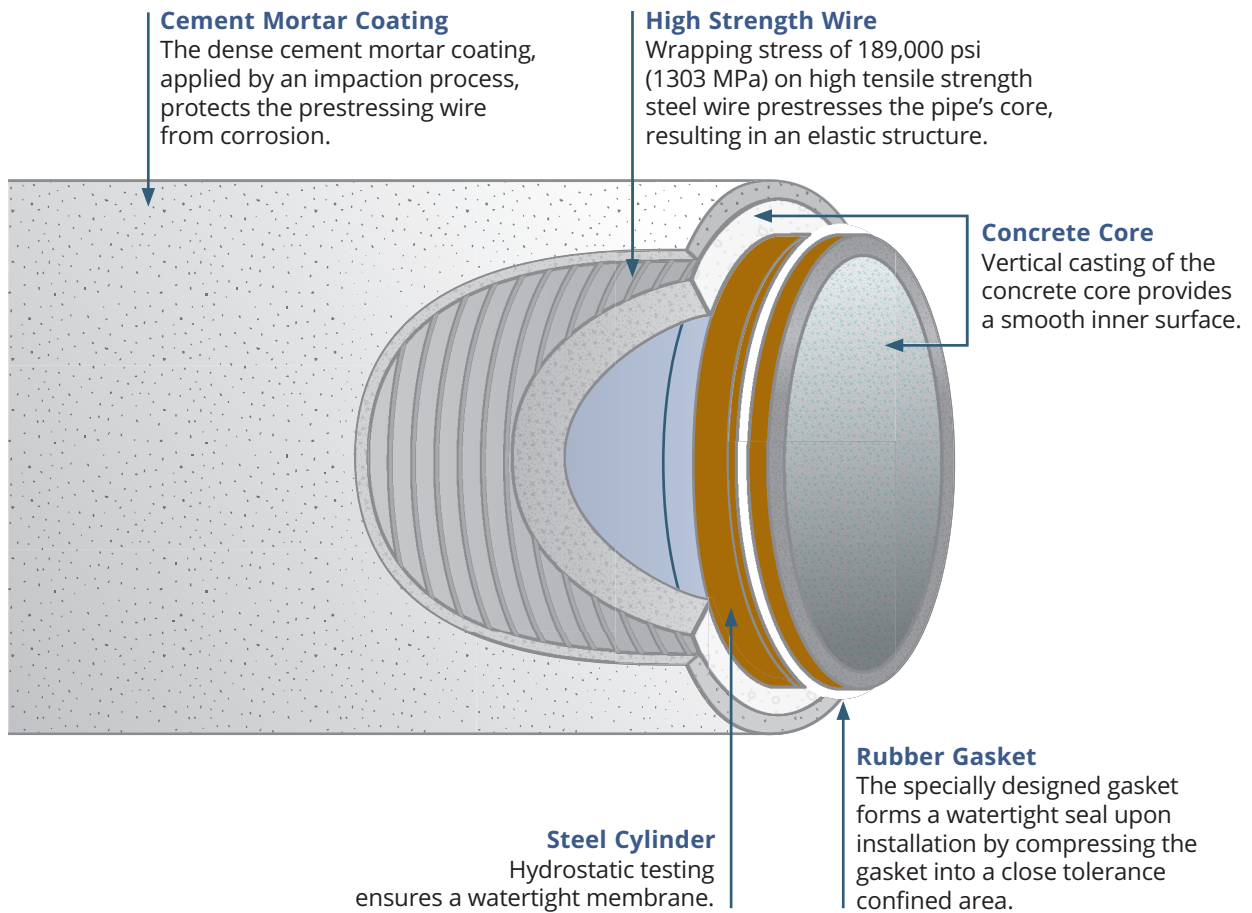

E-301 Standard Dimensions

(For pipe made in Texas)

Pipe Diameter (inches)	Core Thickness (inches)	Joint Depth (inches)	Joint Diameter (inches)	Cylinder Inside/ Outside Diameter (inches)	Approximate Weight (pounds per linear foot)	Nominal Pipe Outside Diameter (inches)	Nominal Laying Length (feet)
54	4	4-1/2	58	57-1/2	1000	64	20
60	4-1/4	4-1/2	64	63-1/2	1175	70-1/2	20
66	5	4-1/2	70	69-1/2	1470	78	16
72	5-1/4	4-1/8	76-1/2	76	1660	84-1/2	24
78	5-1/4	4-1/4	82-1/2	82	1790	90-1/2	20
84	5-1/4	4-3/8	88-1/2	88	1930	96-1/2	20
90	5-3/4	4-1/2	94-1/2	94-3/8	2220	103-1/2	20
96	6-1/2	4-5/8	100-1/2	100-3/8	2640	111	16
102	7	4-3/4	106-1/2	106-3/8	2990	118	16
108	7	4-7/8	112-1/2	112-3/8	3150	124	16
114	7-1/2	4-7/8	118-1/2	118-3/8	3530	131	16
120	8	6	124-1/2	124-3/8	3930	138	16
126	8	6	131-7/8	131-5/8	4450	145-1/8	16
132	8-1/2	6	137-7/8	137-5/8	4535	151	16
138	9	6	143-7/8	143-5/8	4990	158	16
144	9	6	149-7/8	149-5/8	5350	164	16

Note: Some pipe may be supplied with a core thickness other than shown on this chart.

E-301 Standard Dimensions

(For pipe made in Florida and Illinois)

Pipe Diameter (inches)	Core Thickness (inches)	Joint Depth (inches)	Joint Diameter (inches)	Cylinder Inside/ Outside Diameter (inches)	Approximate Pipe Weight (pounds per linear foot)	Nominal Pipe Outside Diameter (inches)	Nominal Pipe Laying Length (feet)
36	2-1/4	4-1/2	39	38-1/2	450	42-1/2	20
42	3-1/2	4-1/2	45	44-1/2	725	51	20
48	4	4-1/2	51-1/4	50-3/4	900	58	20
54	4	4-1/8	57-3/4	56-7/8	1000	64	20
60	4-1/2	4-1/4	63-7/8	63	1240	71	20
66	5	4-3/8	70-1/8	69-1/4	1500	78	20
72	5-1/2	4-1/2	76-3/8	75-1/2	1780	85	20
78	6	4-5/8	82-1/2	81-5/8	2060	92	20
84	6-1/2	4-3/4	88-3/4	87-7/8	2390	99-1/8	20
90	6-1/2	4-7/8	94-7/8	94	2540	105-1/8	20
96	6-1/2	4-7/8	101-1/8	100-1/4	2700	111-1/8	20
102	6-1/2	6	106-7/8	106-1/4	2900	117-1/8	20
108	6-3/4	6	113-1/8	112-1/2	3150	123-5/8	20
114	7-1/8	6	120-5/8	120	3450	130-3/8	20
120	8	6	126-5/8	126	3930	137-1/8	16
126	8-1/2	6	132-5/8	132	4450	145-1/8	16
132	8-1/4	6	138-5/8	138	4550	150-5/8	16
138	8-5/8	6	144-5/8	144	4990	157-3/8	16
144	9	6	150-5/8	150	5350	164-1/8	16

*Note: Some pipe may be supplied with a core thickness other than shown on this chart.
AWWA C301 standard allows a 16:1 ratio between pipe internal diameter and core thickness.*

BAR-WRAPPED PIPE (B-303) FEATURES

Bar-wrapped concrete cylinder pipe combines the strength of steel with the structural and protective properties of high strength cement mortar. A round, mild steel bar is helically wound around the steel cylinder and all surfaces are encased in cement mortar. This composite pipe reacts as a unit when resisting internal pressure and external loads.

The basis of design provides a safety factor comparable to other waterworks pipe materials for normal service conditions and surge or water hammer. The stress in the steel components at working pressure is limited to one half the yield strength of the steel.

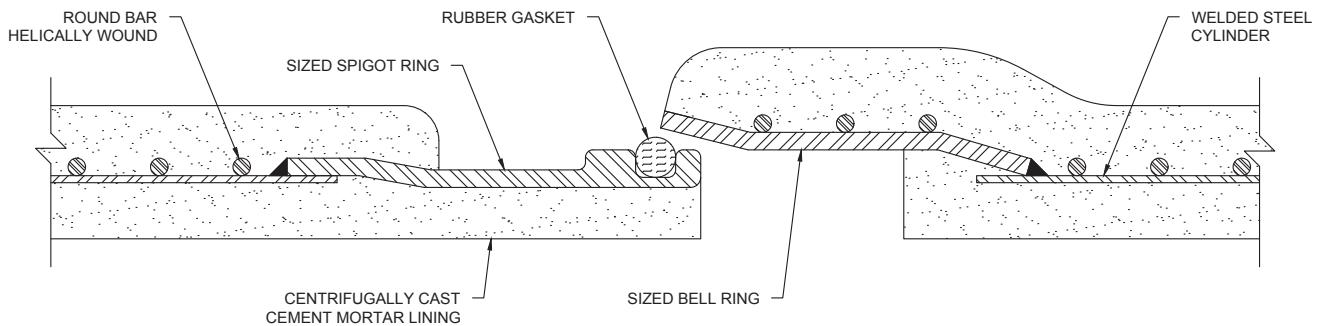

Advantages

Conservative design and rugged construction assures the following benefits:

▶ Long Life

Cement mortar provides maximum protection from corrosion.

▶ Flexible Joints

Watertightness is maintained under normal conditions of soil movement.

▶ Strength

The pipe will withstand normal handling and unplanned concentrated external loadings.

▶ Sustainable High Flow

Tests on older lines reveal a consistently high carrying capacity with a Hazen-Williams coefficient generally in excess of 140.

▶ Economy of Design

Each pipe section is designed to meet the requirements of its unique position in the pipeline with an adequate safety factor and no wasteful overdesign.

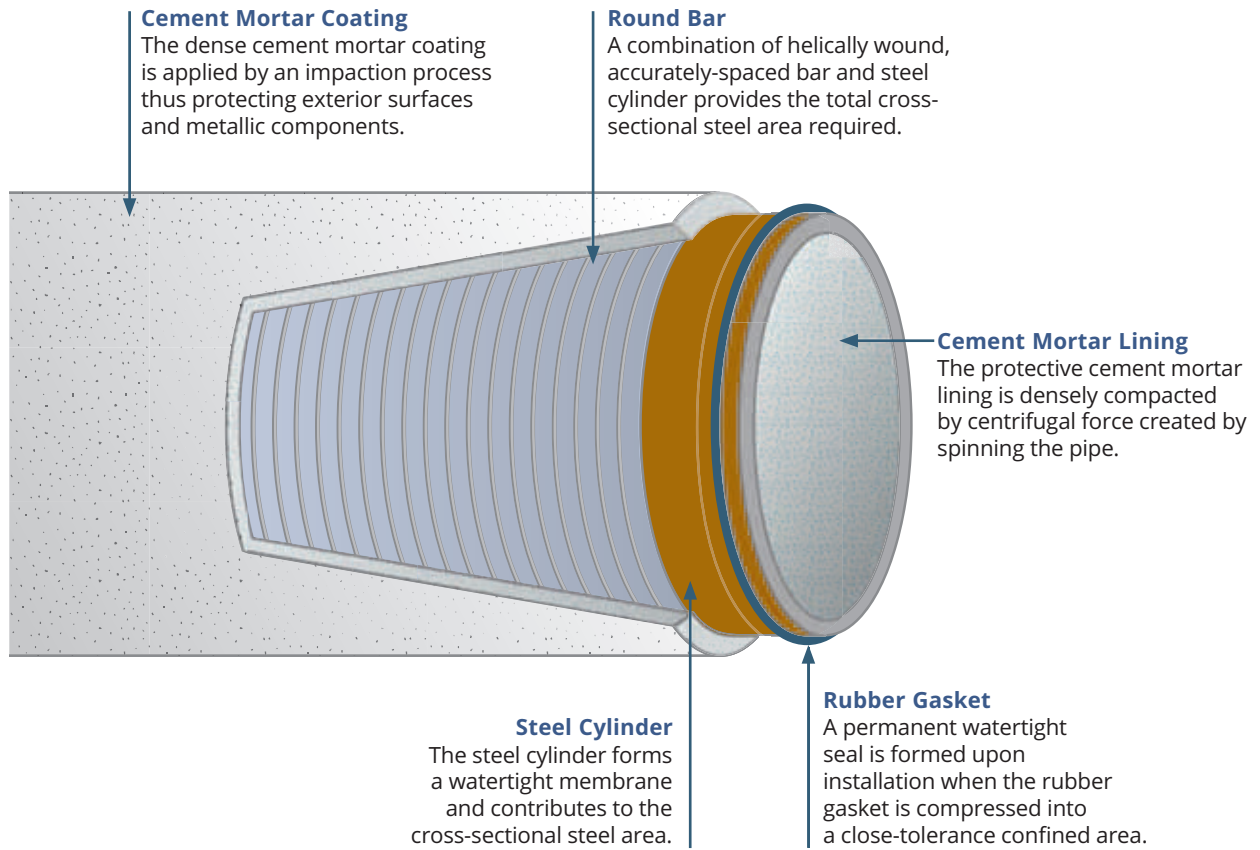

B-303 Standard Dimensions

Pipe Diameter (inches)	Joint Depth (inches)	Joint Diameter (inches)	Cylinder Outside Diameter (inches)	Approximate Weight (pounds per linear foot)	Nominal Bell Outside Diameter (inches)	Nominal Pipe Outside Diameter (inches)	Nominal Laying Length (feet)
10	3-1/4	11-7/8	11-3/8	75	14-1/2	13-1/2	20
12	3-1/4	13-7/8	13-3/8	91	16-1/2	15-1/2	20
14	3-1/4	15-3/4	15-1/4	100	18-1/2	18-1/2	20
16	3-1/4	17-7/8	17-3/8	113	20-1/2	20-1/2	20
18	3-1/4	20-9/32	19-25/32	141	23	22	20
20	3-1/4	22-9/32	21-25/32	157	25	24	20-32
24	3-3/4	26-1/4	25-3/4	188	29	28	20-40
27	3-3/4	29-9/32	28-25/32	222	32	31	20-40
30	3-3/4	32-3/8	31-7/8	247	35	34	20-40
33	3-3/4	35-3/8	34-7/8	282	38	37	20-40
36	3-3/4	36-3/8	37-7/8	316	41	40	20-40
39	3-3/4	41-3/8	40-7/8	347	44	43	20-40
42	3-3/4	44-3/8	43-7/8	375	47	46	20-40
45	3-3/4	47-3/8	46-7/8	416	50	49	20-40
48	3-3/4	50-3/8	49-7/8	450	53	52	20-40
54	3-3/4	56-3/8	55-7/8	522	59	58	20-40
60	3-3/4	62-3/8	61-7/8	557	65	64	20-40
64	3-3/4	66-3/8	65-7/8	613	69	68	24
66	3-3/4	68-3/8	67-7/8	672	71	70	24
72	3-3/4	74-3/8	73-7/8	735	77	76	24



SECTION 4

JOINTS

Standard Joint for L-301, E-301 and B-303

Primary application: This bell and spigot joint is normally used for embedded and lined cylinder prestressed pipes and bar-wrapped pipe.

This joint configuration consists of a steel bell ring and a steel spigot ring which compress a rubber O-ring gasket when assembled. This joint is used in circumstances where other special features such as restraint are not required.

STANDARD JOINT CONSTRUCTION

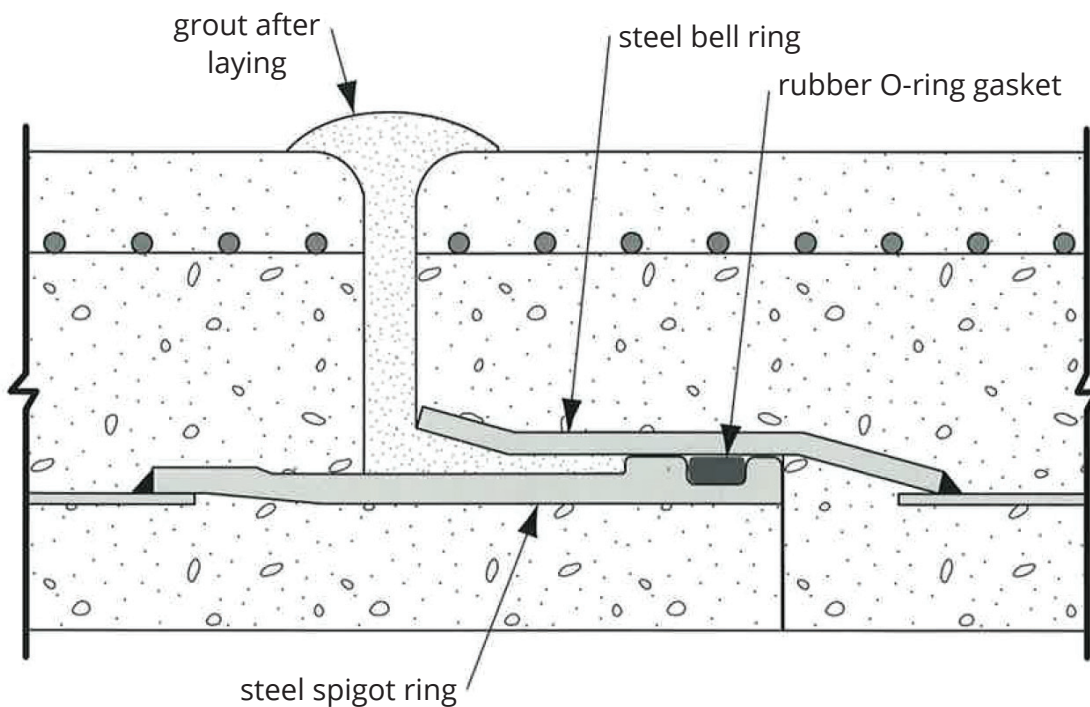

DEEP JOINT

Primary application: This bell and spigot joint is commonly used for lined cylinder prestressed pipe 16 inches through 48 inches in diameter and embedded cylinder prestressed pipe 36 inches through 48 inches in diameter. It can also be used on bar-wrapped pipe.

This joint is constructed in the same fashion as the standard joint described previously except the joint lap is greater to provide additional deflection capability. Deep joints have a minimum joint lap of 4½ inches.

Under certain circumstances, this joint can be supplied on prestressed embedded cylinder pipe 54 inches through 96 inches in diameter. Check with a Thompson Pipe Group representative for more information on availability of deep joints for pipe sizes 54 inches through 96 inches.

DEEP JOINT CONSTRUCTION

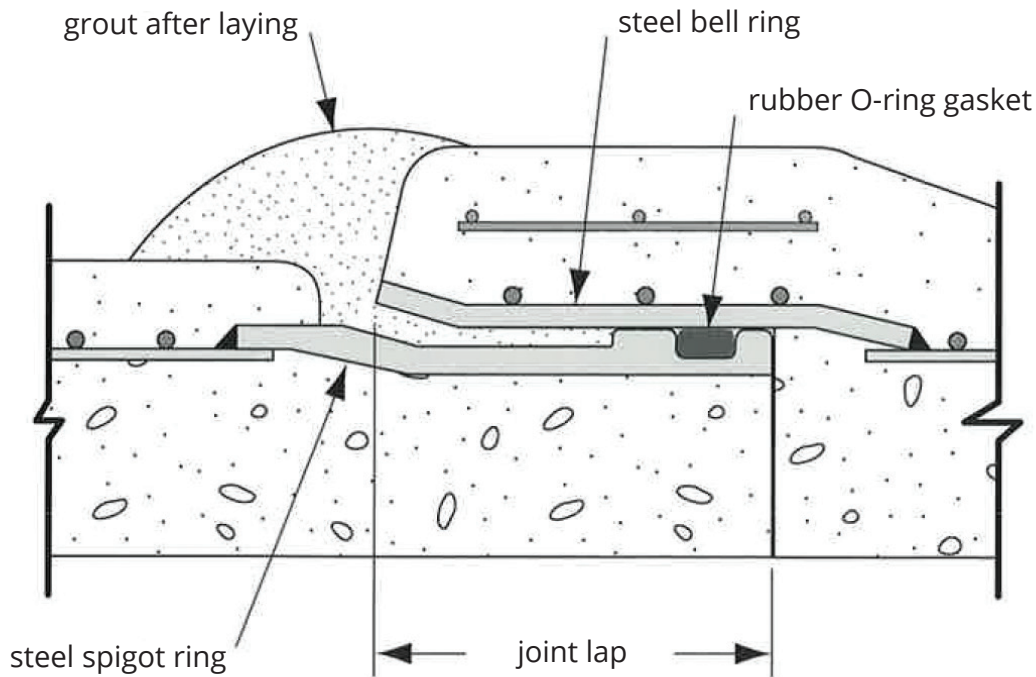

SNAP RING® JOINT

Primary application: This patented joint design provides mechanical restraint for prestressed pipe diameters 16 inches through 66 inches. It can also be supplied on bar-wrapped pipe for diameters 16 inches through 48 inches.

This joint has been offered since 1973 for applications requiring a restrained joint. The outstanding feature of this joint is that it is easier and faster to assemble than any other type of restrained joint.

The joint is completely self-contained and ready to install. Unlike other joint designs, which must be maneuvered into place and held while bolts are aligned and tightened or field welded, the Snap Ring® restraint system is engaged by tightening just one 3/8-inch bolt. The Snap Ring® enables one man to make the joint in just a few minutes using a simple speed wrench. At the same time, the Snap Ring® joint also permits some deflection during installation for slight directional changes or corrections before grouting.

Following installation, the voids around the Snap Ring® are filled with a portland cement grout. Under load, the grout will compress to allow for some settlement. In addition, the grout helps distribute the thrust load uniformly around the joint perimeter. The result is a superior restrained joint that saves installation time in the field.

The thrust-resisting components of this joint are protected from corrosive elements in the soil because they are surrounded by grout.

SNAP RING® JOINT CONSTRUCTION

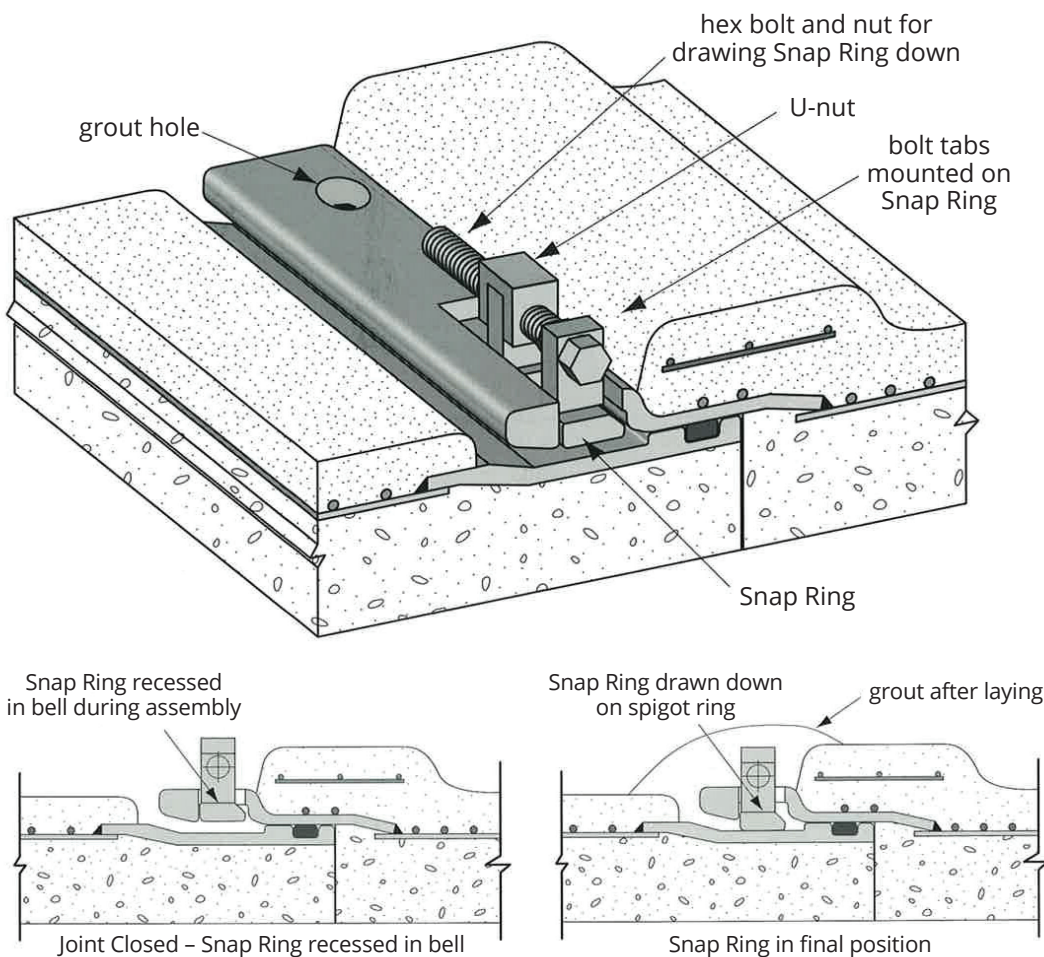

HARNESS CLAMP JOINT

Primary application: This joint provides restraint for prestressed pipe diameters 66 inches and larger and for bar-wrapped pipe 54 inches and larger.

In addition to the Snap Ring® type restrained joint, Thompson Pipe Group offers a clamp-type harness joint. This joint is restrained by a two-part harness clamp. The bottom half of the harness clamp is positioned under the joint prior to placing the next pipe length. After the pipe is installed, the top half of the clamp is positioned over the joint and secured to the bottom half by tightening bolts on each side. Prior to pressurizing the line, portland cement grout is poured into a grout band encapsulating the joint. The portland cement grout distributes any thrust loads around the joint as well as providing corrosion protection for the joint.

HARNESS CLAMP JOINT CONSTRUCTION

Lined cylinder/Bar Wrapped Pipe

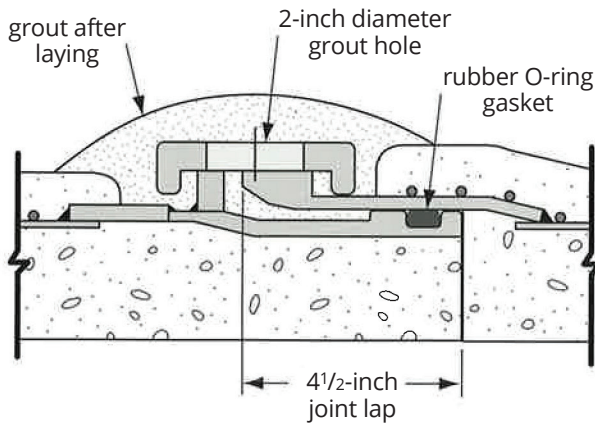

Embedded cylinder pipe

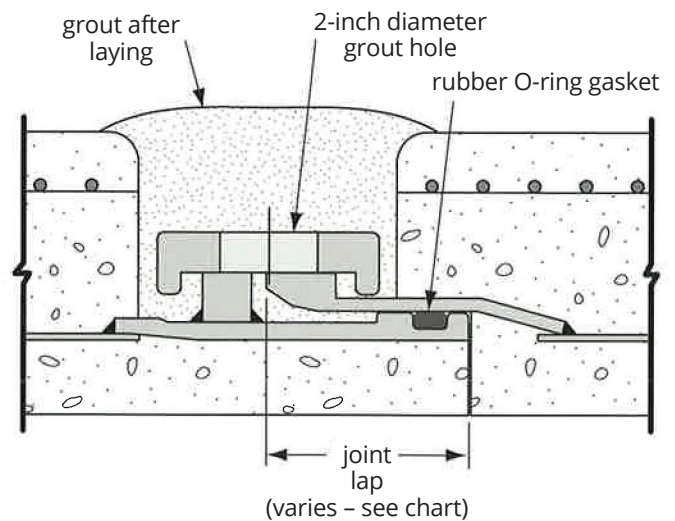

Harness clamp

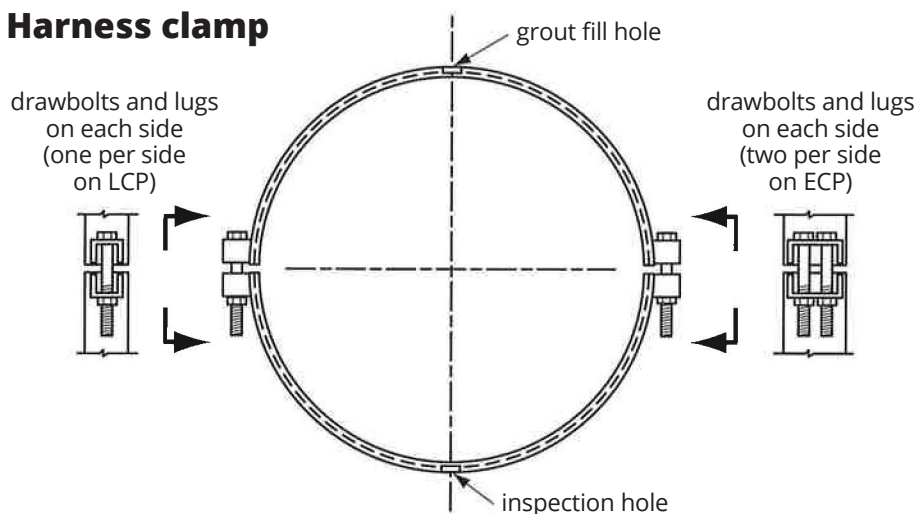

ECP Diameter (inches)	Joint Lap (inches)
54	4-1/8
60	4-1/4
66	4-3/8
72	4-1/2
78	4-5/8
84	4-3/4
90	4-7/8
96	4-7/8

FIELD WELDED JOINT

Welded joints are used to restrain pipe as well as transmit thrust. Depending on pipe size and contractor's preference, welded joints can be either internal or external. Welding from the inside requires a watertight weld due to the absence of the gaskets. For smaller diameters and external welds, the use of a filler rod is required.

FIELD WELDED JOINT CONSTRUCTION

B-303 or L-301

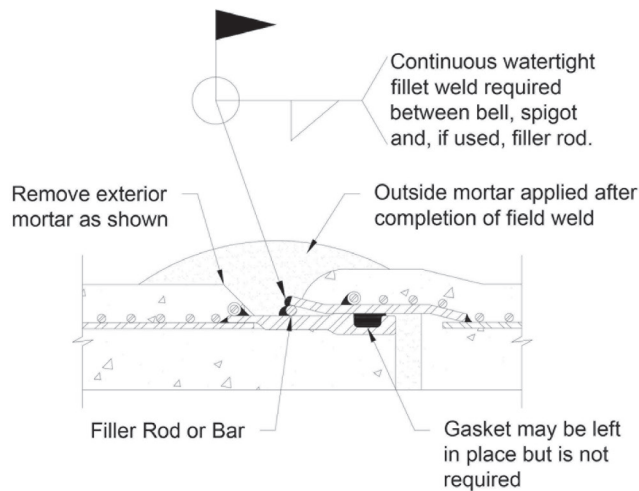

E-301

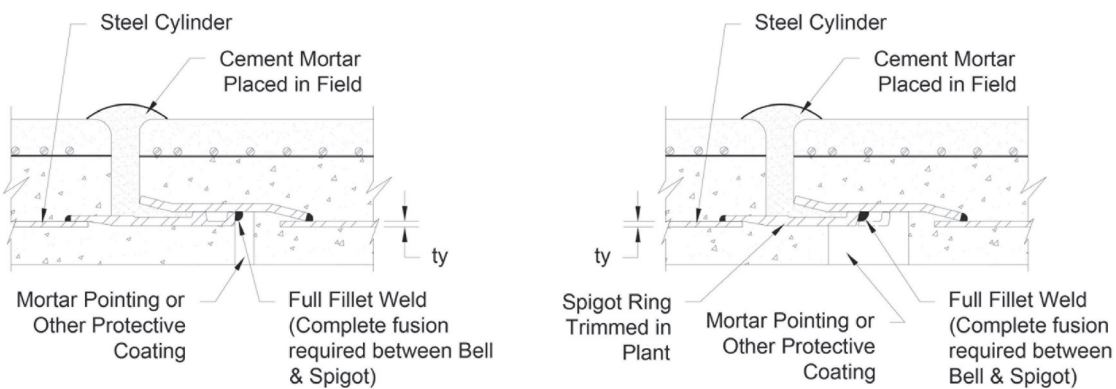

For ty less than $3/16"$, where ty is equal to cylinder thickness.

For ty $3/16"$ or greater, where ty is equal to cylinder thickness.

TESTABLE JOINT

Primary application: Allows testing of joints individually at time of installation.

When large diameter pipe is required in a difficult laying environment where a rolled gasket would be difficult to repair, such as in a casing, under a riverbed, and in power, industrial, water, and wastewater treatment plants, the Thompson testable joint is one of the most effective tools for air testing each joint seal at the time of installation and when it would be easiest to repair a problem. Thompson Pipe Group provides testable joints for Snap Ring® and Harness Clamp restraints.

TESTABLE JOINT CONSTRUCTION

Testable joint construction for E-301 pipe

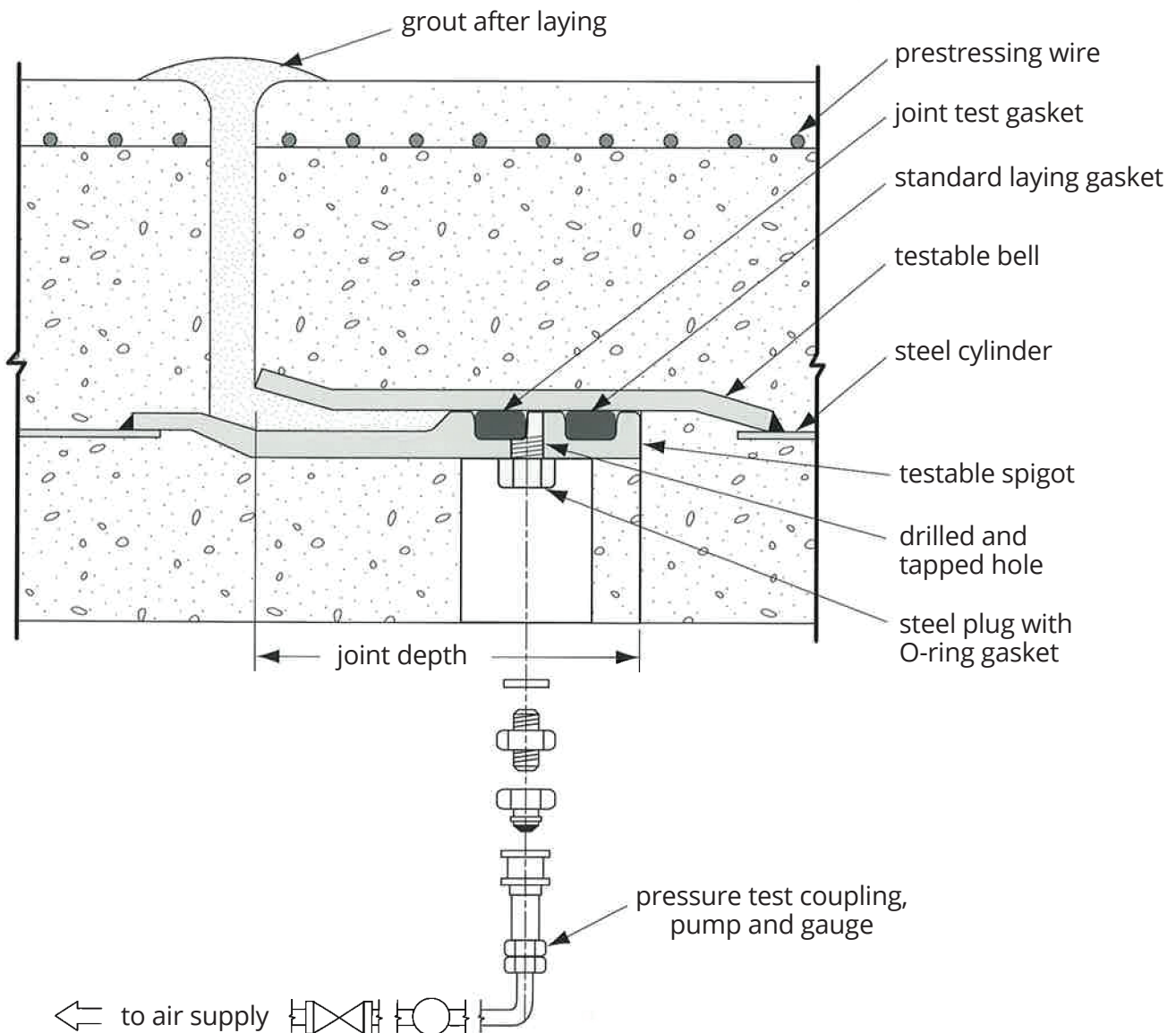

Testable joint construction for B-303 pipe

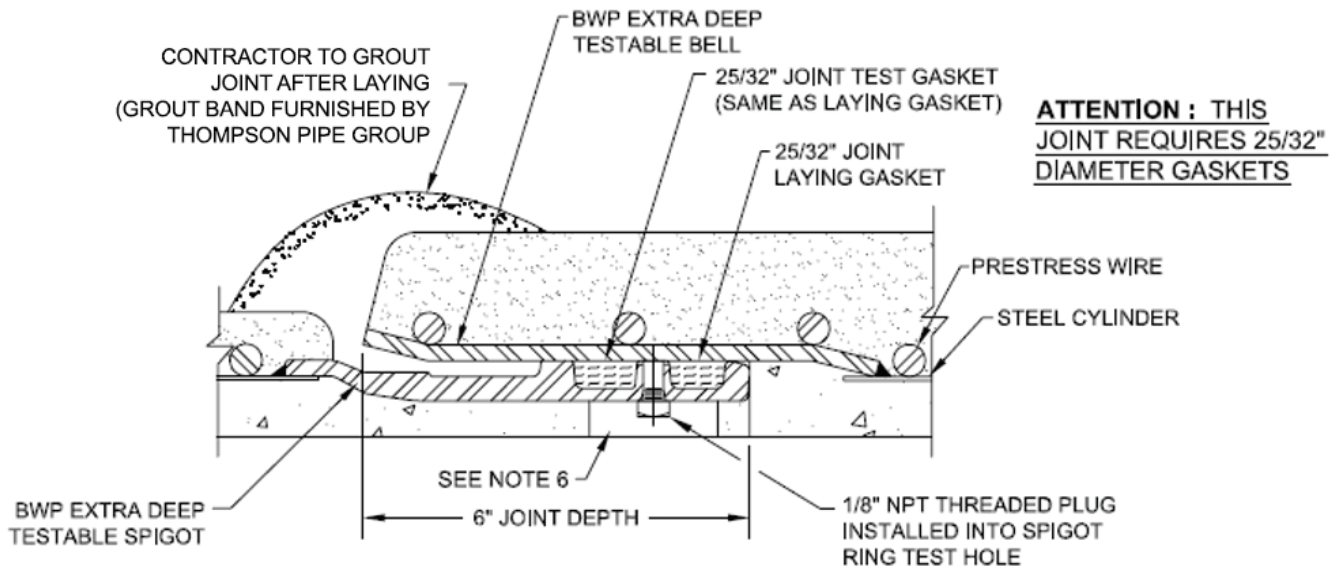

Testable joint construction for L-301 pipe

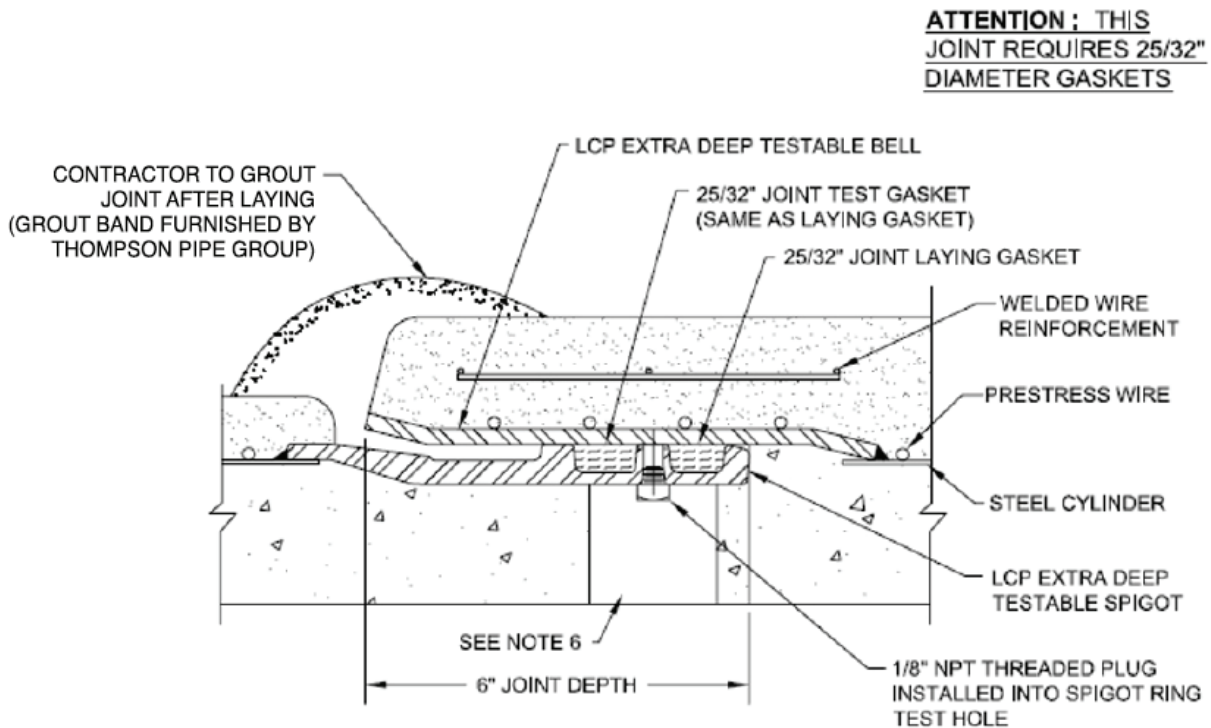

BONDED JOINT

Primary application: This joint allows for monitoring of environmental conditions.

It is seldom necessary to bond concrete pressure pipe joints for the purpose of achieving electrical continuity, unless stray currents are known to exist. In most environments, joint bonding is unnecessary and should be avoided. Recommendations for where and when it is necessary to bond concrete pressure lines are presented in Section Seventeen.

If bonding is necessary, Thompson can provide steel plates at each end of pipe and fittings so that a field exothermic fusion weld can be made across the joint as the pipe is installed. For L-301 and B-303, a steel “U” clip can be field welded to the joints in lieu of the stranded copper cable.

BONDED JOINT CONSTRUCTION

Embedded cylinder pipe Exothermic fusion welded copper cable method

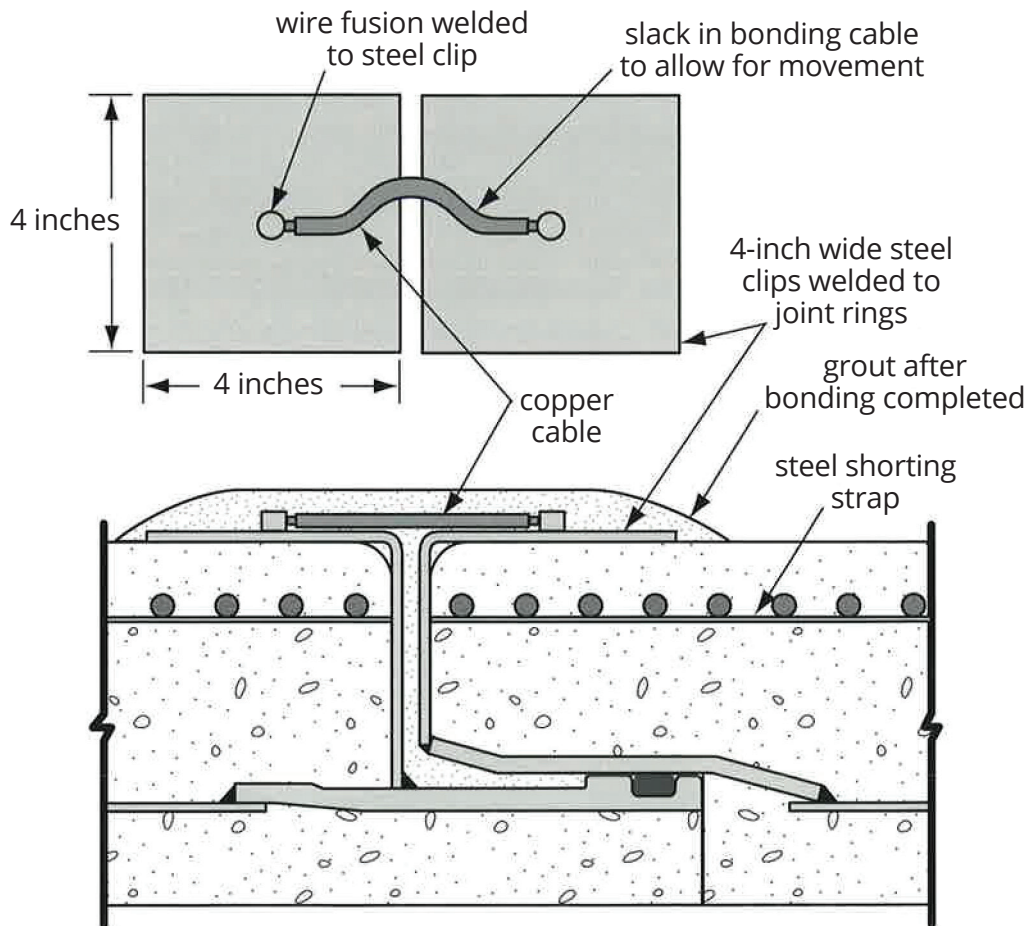

Lined cylinder pipe Exothermic fusion welded copper cable method

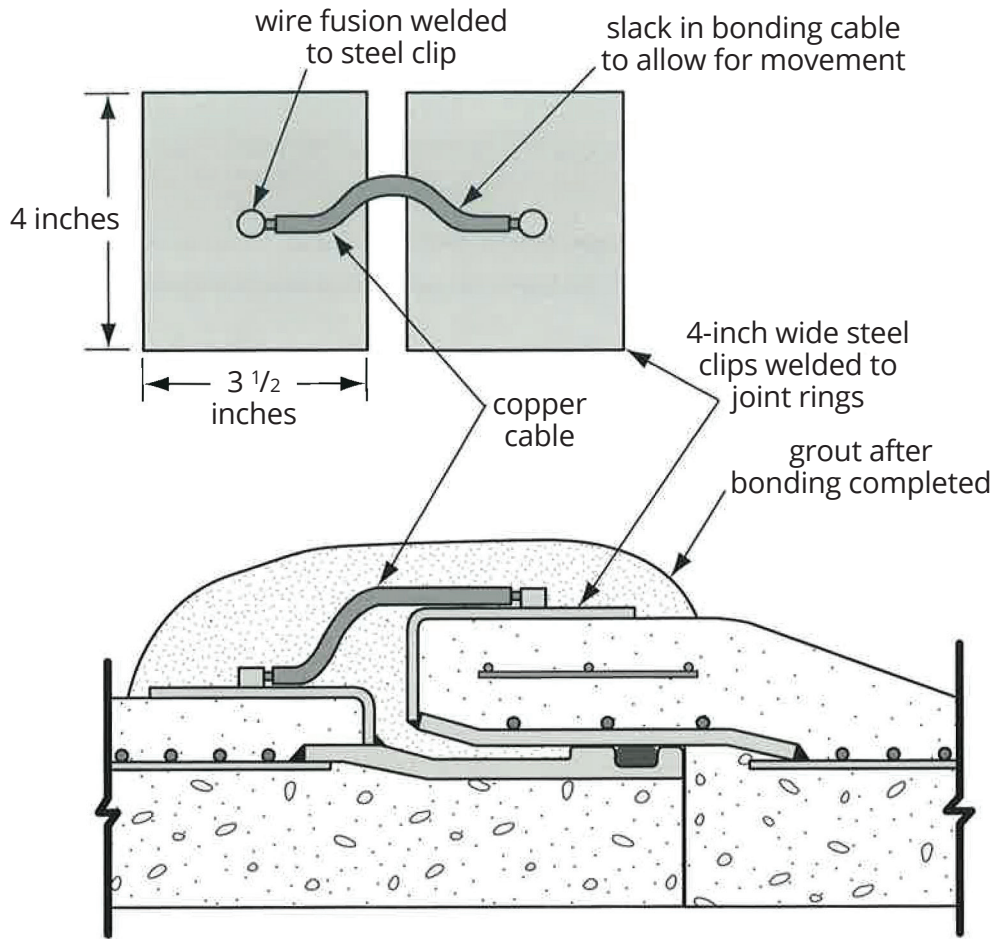

Field-welded U-clip method - E-301

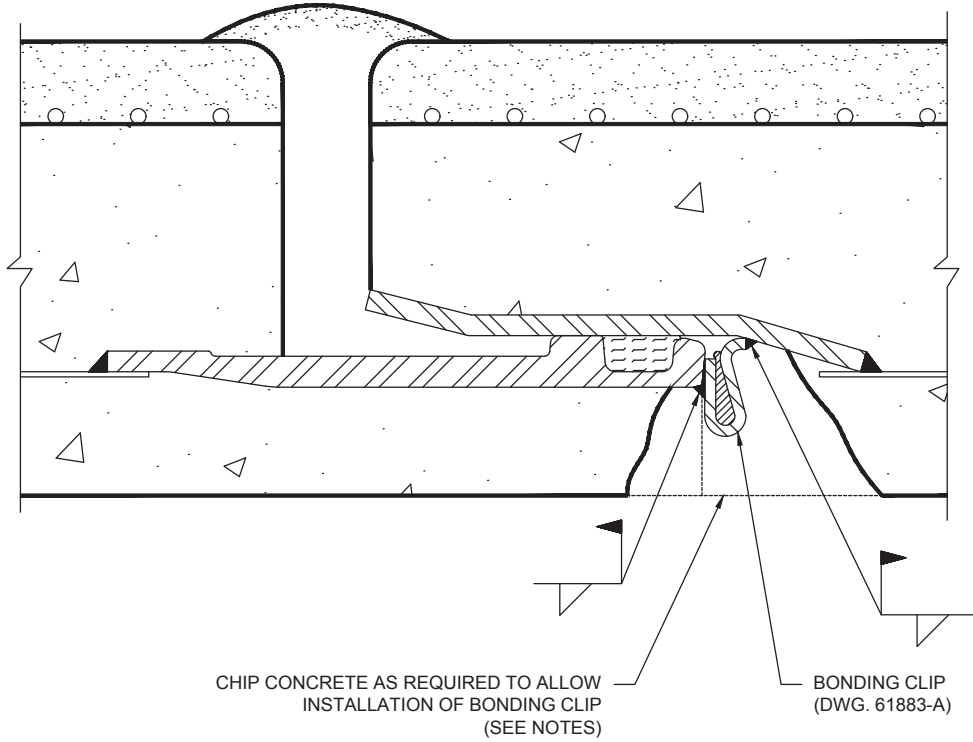

NOTES:

1. MORTAR OVER BONDING CLIP HOLE AFTER JOINTING AND BONDING IS COMPLETE.
2. USE ONE BONDING CLIP PER JOINT UNLESS OTHERWISE REQUIRED BY PROJECT.

Field-welded U-clip method - L-301 and B-303

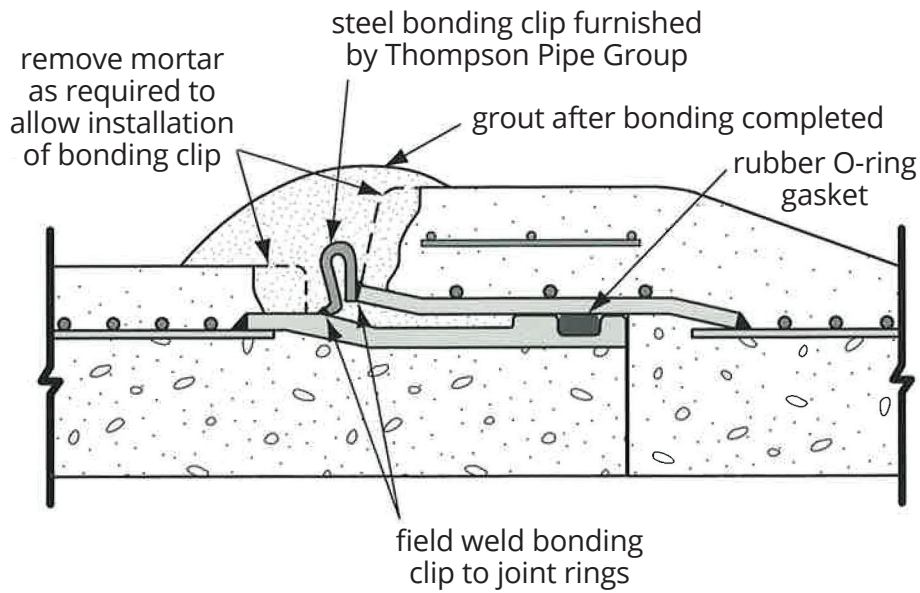

BALL JOINT

Primary application: This joint system is used mainly for river crossings and other installations where significant joint rotations might be required.

The ball joint combines longitudinal thrust restraint with a high degree of rotation of up to 15 degrees in any direction.

After joining the pipe, the closely machined spherical ball-and-socket ends remain free to rotate in any direction. A compressed, lubricated gasket maintains the watertight seal in the deflected position. The ball joint is a good choice for many subaqueous installations because it allows the pipe to conform to the river bottom contour while providing thrust restraint.

At river crossings, for instance, separate pipe sections can be joined on one bank as the line is pulled across from the other side.

The Thompson Pipe Group ball joint is most commonly used in pipe up to 48 inches in diameter. Generally, this type of pipe is supplied in 40-foot lengths by shop-welding two 20-foot pipe sections together, but can also be supplied in 20-foot lengths.

BALL JOINT CONSTRUCTION

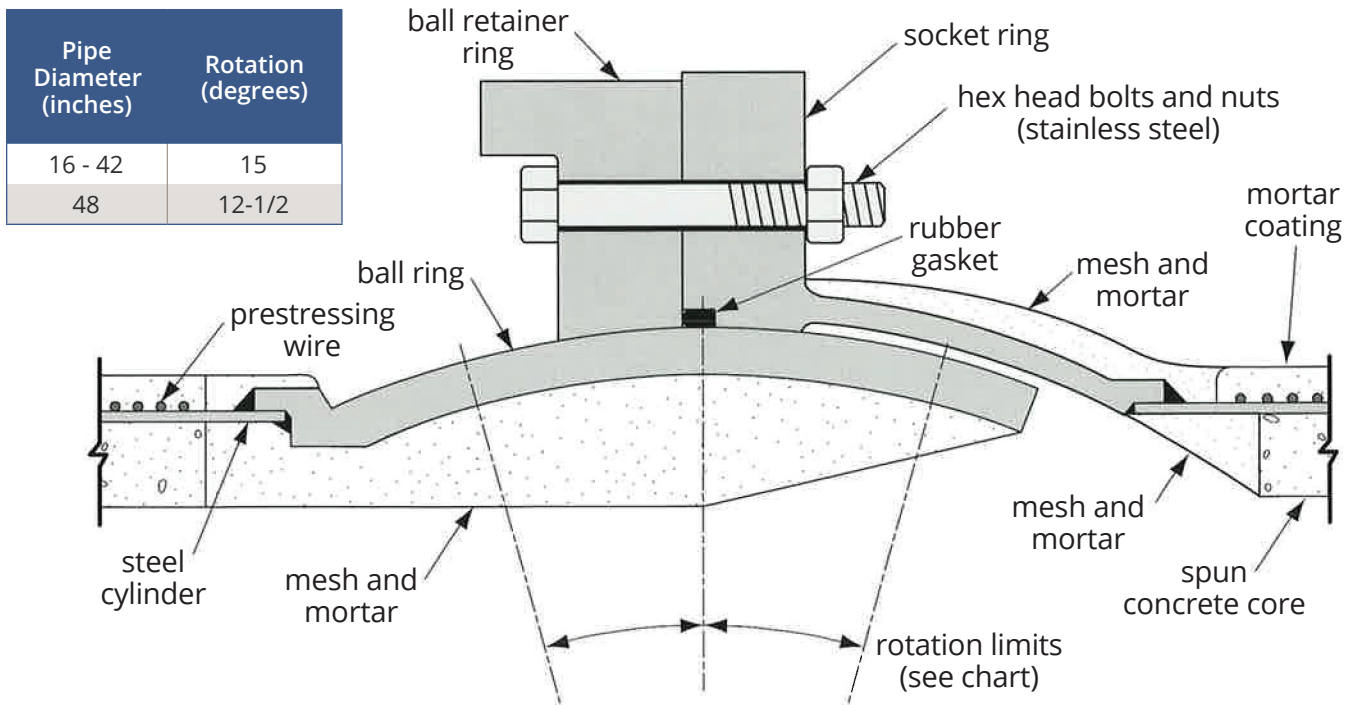

EXTRA DEEP JOINT

Primary application: This joint is used on prestressed pipe sections where additional joint flexibility is required such as soil settlement.

This joint was originally designed to meet the special conditions found in earth fill dams. The principal requirement of such conditions is that the joints must have greater flexibility and extensibility. This is accomplished by increasing the joint depth, thereby increasing the allowable joint opening.

With this joint, slope changes of up to 18 percent and deflection angles as great as 10 degrees can be provided without compromising the joint seal. Deflection tables for the extra deep joint are provided in Section Five.

EXTRA DEEP JOINT CONSTRUCTION

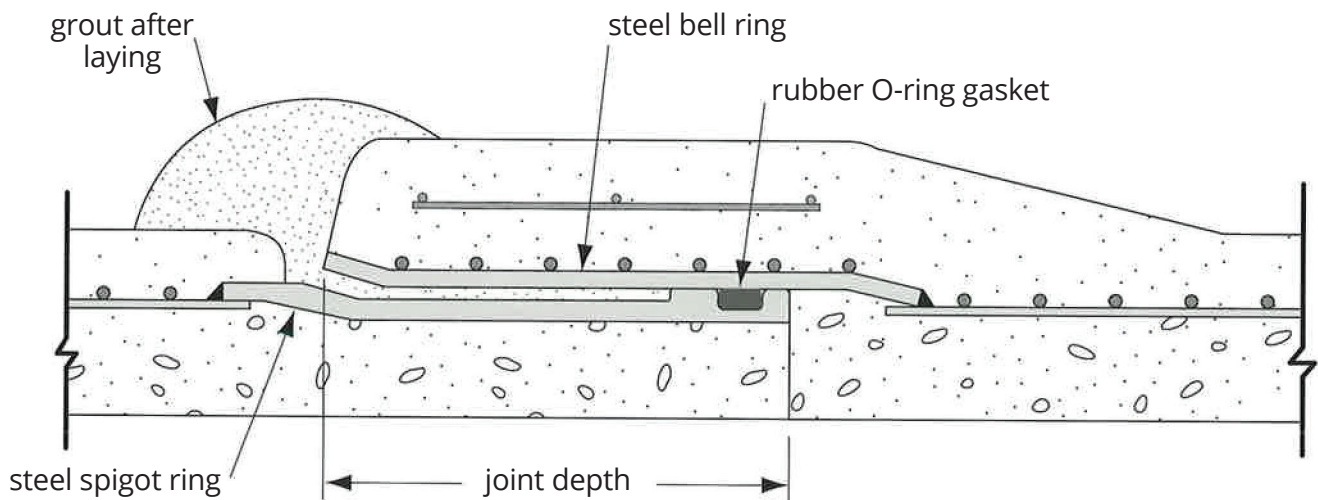

Thompson Pipe Group manufactures joints with three layers of protection. Unlike the pipe itself, in which steel components are encased in protective concrete, sealing portions of the steel joint rings are not encased. To protect these steel components, three layers of exterior protection are incorporated:

- ▶ Zinc metallized coating
- ▶ Cement mortar
- ▶ Typar/Ethafoam

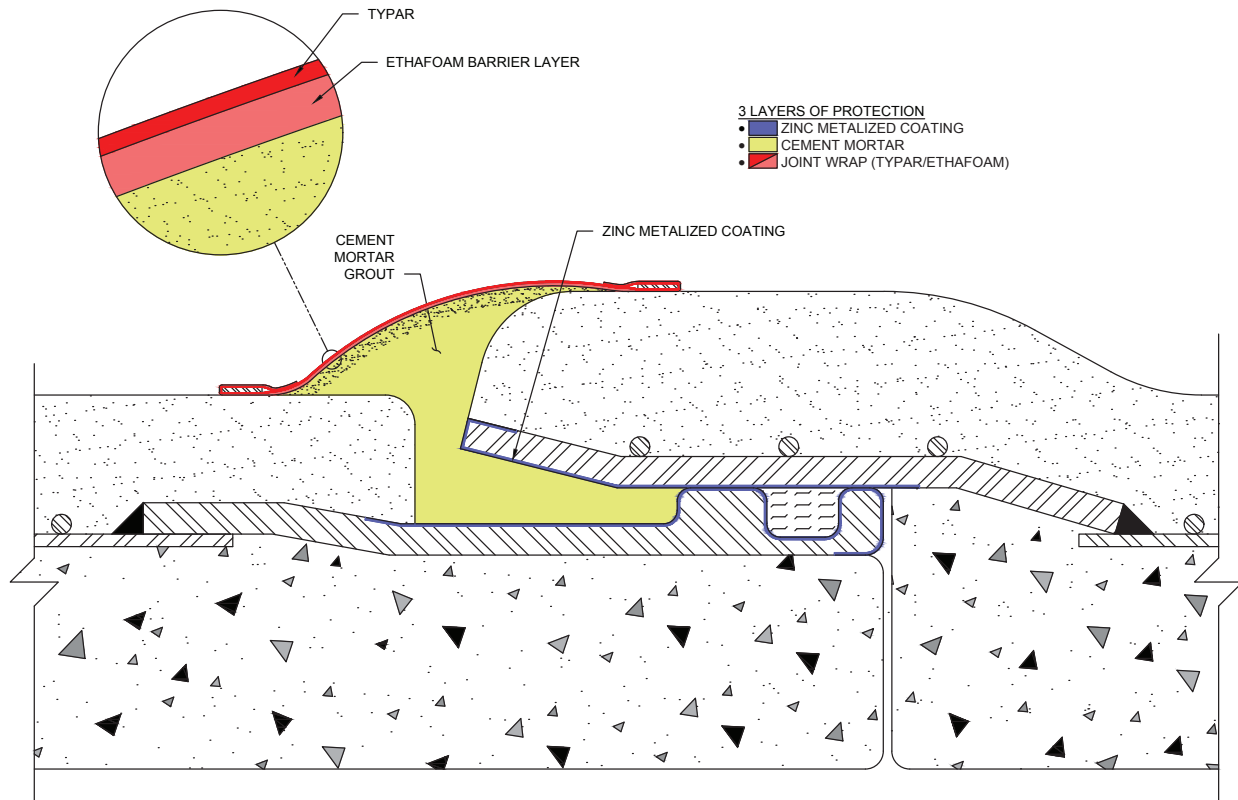

ZINC METALLIZED COATING

The Thompson Pipe Group facility in Bakewell, Tennessee, manufactures and metalizes steel joint rings. These rings are used in all Thompson facilities to produce prestressed concrete cylinder pipe (AWWA C301) and bar-wrapped pipe (AWWA C303). The use of zinc metallized rings provides corrosion protection for the steel joint rings and eliminates the need to mortar point the interior joints on water and treated wastewater lines.

Zinc metalizing provides corrosion protection for the steel in two ways: as a barrier and through galvanic action.

APPLICATION

Steel joint ring stock moves through a cabinet to be abrasively cleaned. Once properly cleaned of all scale and rust, the steel sections move down a conveyor belt into an enclosed metal cabinet.

Once a section reaches the enclosure, zinc wire is fed into multiple applications, atomized and propelled onto steel. Heat atomizes the zinc into tiny droplets. A nozzle directs a stream of high pressure compressed air and sprays the zinc droplets onto the steel. The liquid cools quickly and provides a continuous protective barrier.

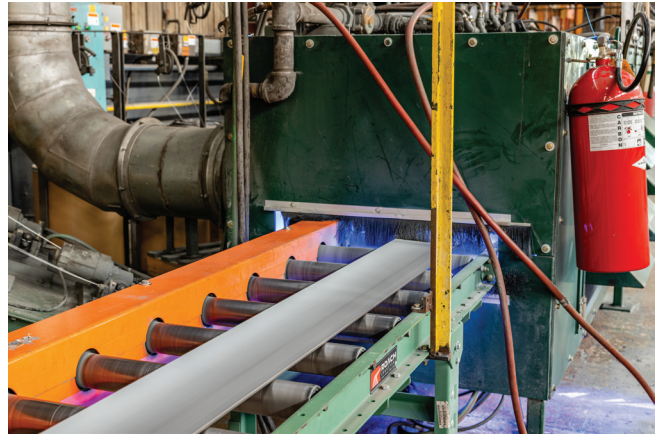
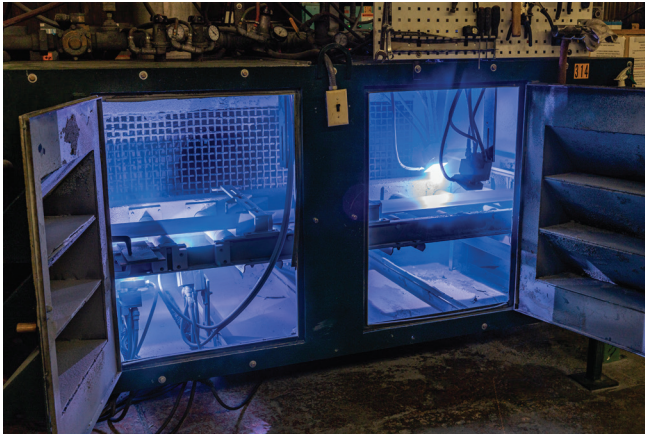



BEVELS AND DEFLECTION

Bevel Pipe

A bevel pipe is manufactured by placing the spigot ring at an angle on the end of a full length of pipe, which permits greater pipe deflection than that possible with the standard joint. A bevel pipe has a long and a short side. A “full” bevel pipe has a difference between the long and short side of 1 inch per foot of pipe diameter. A “half” bevel pipe has a difference of 1/2 inch per foot of pipe diameter.

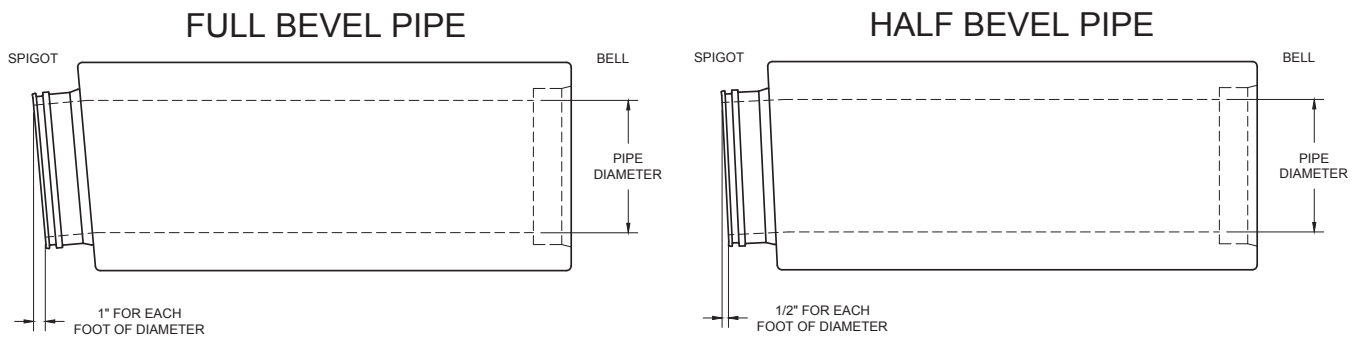

Deflection

The deflection tables that accompany this section indicate the recommended maximum joint opening for lined cylinder pipe (L-301) and embedded cylinder pipe (E-301) in each diameter for 20-foot laying lengths. Bar-wrapped pipe (B-303) deflection tables are included. The maximum recommended joint opening for layout purposes on unrestrained joints is shown in the deflection tables. In all cases, the joint can be opened an additional 1/2 inch beyond the recommendations in these tables without losing seal. All restrained joints, however, are limited to a maximum joint opening of 1/2 inch.

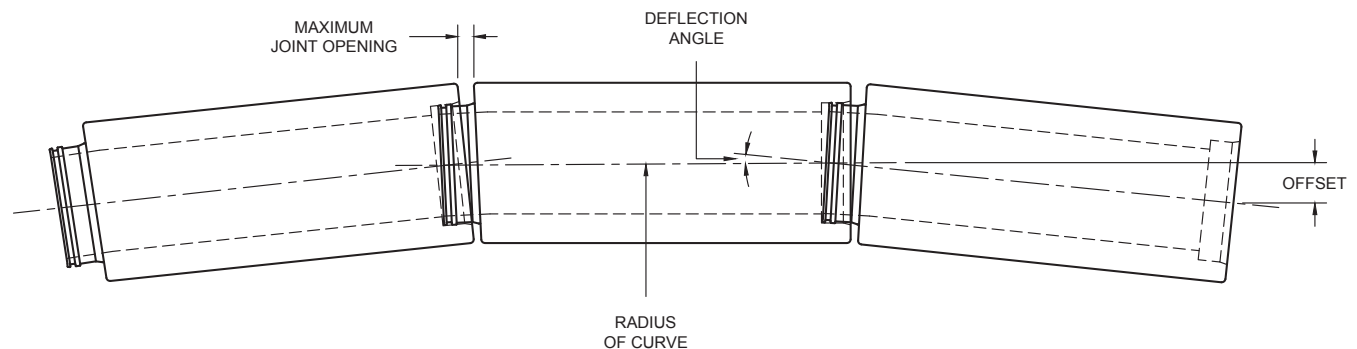

Horizontal and Vertical Curves

One common use for deflected deep joint, standard joint, and bevel pipe is to negotiate large-radius horizontal and vertical curves. Using the pipe in this way eliminates the need for elbow fittings. The project site must, in this case, have sufficient room to handle the long-radius curves. The deflection tables that follow indicate the curve radii and offsets possible with deep joints, standard joints and bevel joints.

DEFLECTION TABLE – B-303 STANDARD JOINTS

Pipe Diameter (inches)	Joint Depth (inches)	Maximum Joint Opening (inches)	Maximum Deflection Angle (degrees)	Maximum Offset (inches)	Minimum Curve Radius (feet)	Average Laying Length (feet)
16 B-303	3-1/4	3/4	2.40	10-1/16	477	20
18 B-303	3-1/4	3/4	2.12	8-7/8	541	20
20 B-303	3-1/4	3/4	1.93	12-7/8	951	32
24 B-303	3-3/4	3/4	1.63	12	1225	35
27 B-303	3-3/4	3/4	1.47	10-3/4	1367	35
30 B-303	3-3/4	3/4	1.33	9-3/4	1511	35
33 B-303	3-3/4	3/4	1.22	8-7/8	1651	35
36 B-303	3-3/4	3/4	1.12	8-1/4	1791	35
39 B-303	3-3/4	3/4	1.03	7-5/8	1931	35
42 B-303	3-3/4	3/4	0.97	7-1/8	2071	35
45 B-303	3-3/4	3/4	0.90	6-5/8	2211	35
48 B-303	3-3/4	3/4	0.85	6-1/4	2351	35
54 B-303	3-3/4	3/4	0.77	5-9/16	2631	35
60 B-303	3-3/4	3/4	0.69	5-1/16	2911	35
64 B-303	3-3/4	3/4	0.65	3-1/4	2124	24
66 B-303	3-3/4	3/4	0.63	3-3/16	2188	24
72 B-303	3-3/4	3/4	0.58	2-7/8	2380	24

DEFLECTION TABLE – L-301 & E-301 DEEP JOINTS

Pipe Diameter (inches)	Joint Depth (inches)	Maximum Joint Opening (inches)	Maximum Deflection Angle (degrees)	Maximum Offset (inches)	Minimum Curve Radius (feet)	Average Laying Length (feet)
16 L-301	4-1/2	1-3/4	5.40	22-5/8	215	19.93
18 L-301	4-1/2	1-3/4	4.82	20-3/16	240	19.93
20 L-301	4-1/2	1-3/4	4.35	18-1/4	265	19.93
24 L-301	4-1/2	1-3/4	3.64	15-1/4	315	19.93
30 L-301	4-1/2	1-3/4	2.92	12-1/4	395	19.93
36 L-301	4-1/2	1-3/4	2.44	10-1/4	470	19.94
42 L-301	4-1/2	1-3/4	2.12	8-7/8	545	19.97
48 L-301	4-1/2	1-3/4	1.86	7-13/16	620	19.98
36 E-301	4-1/2	1-3/4	2.57	10-3/4	450	19.94
42 E-301	4-1/2	1-3/4	2.23	9-5/16	515	19.97
48 E-301	4-1/2	1-3/4	1.96	8-3/16	590	19.98
54 E-301	5-1/8	1-7/8	1.85	7-3/4	620	19.95
60 E-301	5-1/4	2	1.80	7-1/2	640	19.95
66 E-301	5-3/8	2-1/8	1.73	7-1/4	665	19.96
72 E-301	5-1/2	2-1/4	1.68	7	685	19.96
78 E-301	5-5/8	2-3/8	1.65	6-7/8	700	19.96
84 E-301	5-3/4	2-1/2	1.62	6-3/4	710	19.96
90 E-301	5-7/8	2-5/8	1.58	6-5/8	725	19.97
96 E-301	5-7/8	2-5/8	1.49	6-1/4	780	19.97

DEFLECTION TABLE – E-301 STANDARD JOINT

Pipe Diameter (inches)	Joint Depth (inches)	Maximum Joint Opening (inches)	Maximum Deflection Angle (degrees)	Maximum Offset (inches)	Minimum Curve Radius (feet)	Average Laying Length (feet)
54 E-301	4-1/8	7/8	0.87	3-5/8	1325	20.03
60 E-301	4-1/4	1	0.90	3-3/4	1280	20.03
66 E-301	4-3/8	1-1/8	0.92	3-7/8	1250	20.04
72 E-301	4-1/2	1-1/4	0.94	3-15/16	1225	20.04
78 E-301	4-5/8	1-3/8	0.95	4	1205	20.04
84 E-301	4-3/4	1-1/2	0.97	4-1/16	1190	20.04
90 E-301	4-7/8	1-5/8	0.98	4-1/8	1175	20.05
96 E-301	4-7/8	1-5/8	0.92	3-7/8	1250	20.05
102 E-301	6	2-1/2	1.34	5-5/8	860	20.05
108 E-301	6	2-1/2	1.27	5-5/16	910	20.05
114 E-301	6	2-1/2	1.19	5	970	20.05
120 E-301	6	2-1/2	1.13	3-3/4	815	16.06
126 E-301	6	2-1/2	1.08	3-5/8	855	16.06
132 E-301	6	2-1/2	1.03	3-1/2	895	16.06
138 E-301	6	2-1/2	0.99	3-5/16	930	16.06
144 E-301	6	2-1/2	0.95	3-3/16	970	16.06

DEFLECTION TABLE – L-301 & E-301 FULL BEVEL PIPE

Pipe Diameter (inches)	Joint Depth (inches)	Maximum Joint Opening (inches)	Range of Deflection Angle (degrees)	Range of Offset (inches)	Range of Curve Radius (feet)	Average Laying Length (feet)
16 L-301	4-1/2	1-3/4	0.00-9.53	0 to 39-11/16	120 to ∞	19.87
18 L-301	4-1/2	1-3/4	0.00-8.96	0 to 37-5/16	130 to ∞	19.87
20 L-301	4-1/2	1-3/4	0.00-8.50	0 to 35-3/8	135 to ∞	19.86
24 L-301	4-1/2	1-3/4	0.52-7.80	2-3/16 to 32-1/2	150 to 2205	19.85
30 L-301	4-1/2	1-3/4	1.25-7.10	5-3/16 to 29-9/16	165 to 915	19.83
36 L-301	4-1/2	1-3/4	1.74-6.63	7 1/4 to 27-9/16	175 to 655	19.82
42 L-301	4-1/2	1-3/4	2.12-6.36	8-13/16 to 26-7/16	180 to 540	19.82
48 L-301	4-1/2	1-3/4	2.38-6.09	9-7/8 to 25-5/16	190 to 480	19.81
36 E-301	4-1/2	1-3/4	1.83-6.97	7-5/8 to 29	165 to 625	19.82
42 E-301	4-1/2	1-3/4	2.22-6.67	9-1/4 to 27-3/4	175 to 515	19.82
48 E-301	4-1/2	1-3/4	2.51-6.42	10-7/16 to 26-5/8	180 to 455	19.81
54 E-301	4-1/8	7/8	3.59-5.32	14-7/8 to 22-1/16	215 to 320	19.84
60 E-301	4-1/4	1	3.58-5.26	14-7/8 to 22-1/4	215 to 320	19.82
66 E-301	4-3/8	1-1/8	3.57-5.40	14-13/16 to 22-3/8	210 to 320	19.81
72 E-301	4-1/2	1-1/4	3.55-5.43	14-3/4 to 22-1/2	210 to 320	19.79
78 E-301	4-5/8	1-3/8	3.55-5.46	14-11/16 to 22-9/16	210 to 320	19.77
84 E-301	4-3/4	1-1/2	3.54-5.48	14-5/8 to 22-5/8	210 to 320	19.75
90 E-301	4-7/8	1-5/8	3.54-5.50	14-5/8 to 22-11/16	210 to 320	19.74
96 E-301	4-7/8	1-5/8	3.60-5.44	14-7/8 to 22-7/16	210 to 315	19.72
102 E-301	6	2-1/2	3.21-5.89	13-1/4 to 24-1/4	195 to 355	19.70
108 E-301	6	2-1/2	3.28-5.81	13-1/2 to 23-15/16	195 to 345	19.68
114 E-301	6	2-1/2	3.32-5.69	13-5/8 to 23-3/8	200 to 340	19.65
120 E-301	6	2-1/2	3.38-5.65	11-1/16 to 18-1/2	155 to 265	15.64
126 E-301	6	2-1/2	3.45-5.61	11-1/4 to 18-5/16	160 to 260	15.62
132 E-301	6	2-1/2	3.50-5.57	11-7/16 to 18-3/16	165 to 255	15.60
138 E-301	6	2-1/2	3.56-5.54	11-5/8 to 18-1/16	165 to 255	15.58
144 E-301	6	2-1/2	3.60-5.51	11-3/4 to 17-15/16	165 to 250	15.56

DEFLECTION TABLE – L-301 & E-301 HALF BEVEL PIPE

Pipe Diameter (inches)	Joint Depth (inches)	Maximum Joint Opening (inches)	Range of Deflection Angle (degrees)	Range of Offset (inches)	Range of Curve Radius (feet)	Average Laying Length (feet)
16 L-301	NOT MADE	NOT MADE	NOT MADE	NOT MADE	NOT MADE	NOT MADE
18 L-301	NOT MADE	NOT MADE	NOT MADE	NOT MADE	NOT MADE	NOT MADE
20 L-301	4-1/2	1-3/4	0.00-6.43	0 to 26-7/8	180 to ∞	19.90
24 L-301	4-1/2	1-3/4	0.00-5.72	0 to 23-15/16	2.00 to ∞	19.89
30 L-301	4-1/2	1-3/4	0.00-5.02	0 to 20-15/16	230 to ∞	19.88
36 L-301	4-1/2	1-3/4	0.00-4.54	0 to 18-11/16	255 to ∞	19.88
42 L-301	4-1/2	1-3/4	0.00-4.24	0 to 17-11/16	270 to ∞	19.90
48 L-301	4-1/2	1-3/4	0.2673.98	1-1/8 to 16-5/8	290 to 4315	19.90
36 E-301	4-1/2	1-3/4	0.00-4.77	0 to 19-15/16	240 to ∞	19.88
42 E-301	4-1/2	1-3/4	0.00-4.45	0 to 18-5/8	260 to ∞	19.90
48 E-301	4-1/2	1-3/4	0.28-4.19	1-3/16 to 17-1/2	275 to 4095	19.90
54 E-301	4-1/8	7/8	1.36-3.10	5-11/16 to 12-15/16	370 to 840	19.94
60 E-301	4-1/4	1	1.34-3.14	5-5/8 to 13-1/16	365 to 850	19.93
66 E-301	4-3/8	1-1/8	1.33-3.16	5-9/16 to 13-3/16	365 to 865	19.93
72 E-301	4-1/2	1-1/4	1.31-3.19	5-1/2 to 13-5/16	360 to 870	19.92
78 E-301	4-5/8	1-3/8	1.30-3.21	5-7/16 to 13-3/8	355 to 880	19.90
84 E-301	4-3/4	1-1/2	1.29-3.23	5-3/8 to 13-7/16	355 to 885	19.89
90 E-301	4-7/8	1-5/8	1.28-3.24	5-5/16 to 13-1/2	355 to 890	19.89
96 E-301	4-7/8	1-5/8	1.34-3.19	3-5/8 to 13-1/4	360 to 850	19.88
102 E-301	6	2-1/2	0.94-3.62	3-7/8 to 15-1/16	315 to 1215	19.87
108 E-301	6	2-1/2	1.01-3.54	4-3/16 to 14-3/4	325 to 1125	19.86
114 E-301	6	2-1/2	1.07-3.44	4-7/16 to 14-5/16	330 to 1065	19.85
120 E-301	6	2-1/2	1.13-3.39	3-3/4 to 11-1/4	270 to 800	15.85
126 E-301	6	2-1/2	1.19-3.35	3-15/16 to 11-1/8	275 to 765	15.84
132 E-301	6	2-1/2	1.24-3.31	4-1/8 to 10-15/16	275 to 735	15.83
138 E-301	6	2-1/2	1.29-3.27	4-1/4 to 10-13/16	280 to 705	15.82
144 E-301	6	2-1/2	1.33-3.23	4-3/8 to 10-11/16	280 to 685	15.81

DEFLECTION TABLE – L-301 EXTRA DEEP JOINTS

Pipe Diameter (inches)	Joint Depth (inches)	Maximum Joint Opening (inches)	Maximum Deflection Angle (degrees)	Maximum Offset (inches)	Minimum Curve Radius (feet)	Average Laying Length (feet)
16 L-301	6-1/4	3-3/8	10.33	42-9/16	110	19.78
18 L-301	6-1/4	3-3/8	9.23	38-1/16	120	19.78
20 L-301	6-1/4	3-3/8	8.33	34-3/8	135	19.78
24 L-301	6-1/4	3-3/8	7.00	28-15/16	160	19.78
30 L-301	6-1/4	3-3/8	5.63	23-1/4	200	19.78
36 L-301	6-1/4	3-3/8	4.70	19-7/16	240	19.79
42 L-301	6-1/4	3-3/8	4.08	16-15/16	280	19.82
48 L-301	6-1/4	3-3/8	3.58	14-13/16	315	19.83



OUTLET PIPE

Various types of outlets can be incorporated into the wall of concrete pressure pipe during manufacture to accommodate branch lines, manholes, air relief valves, vacuum valves, sampling points and blowoffs. For outlets with end connections other than those shown in this section, see Section Eleven.

To preserve the strength of the pipe wall at the point where the outlet is installed, additional reinforcement is required. Collars, saddles, or reinforcing bands are used, depending on the size and type of outlet.

The position of an outlet is located by reference to the distance from the centerline of the outlet to the spigot end of the pipe.

The distance between the centerline of the outlet and either end of the pipe must be great enough to allow for the additional reinforcement that is required.

Small, threaded outlets can be provided at the joints by welding a steel casting to a reinforcing band attached to the steel cylinder. For larger outlets, the steel outlet neck is centered on and welded to a reinforcing band or collar attached to the pipe cylinder.

Typical threaded outlet in lined cylinder pipe (LCP)

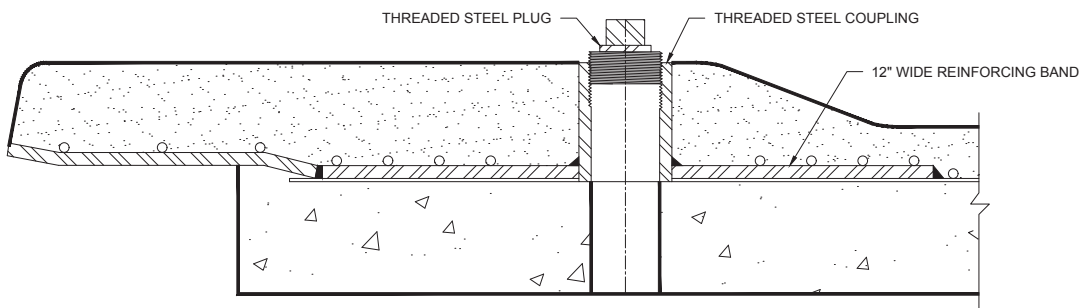
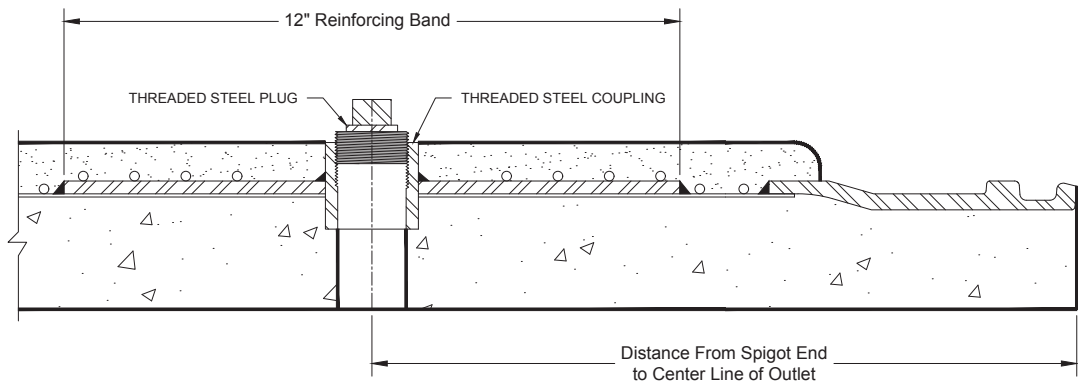

Typical threaded outlet in embedded cylinder pipe (ECP)

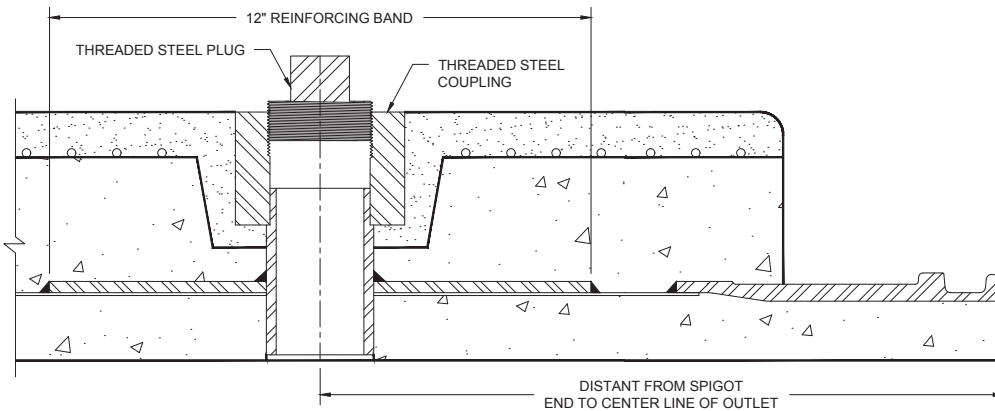
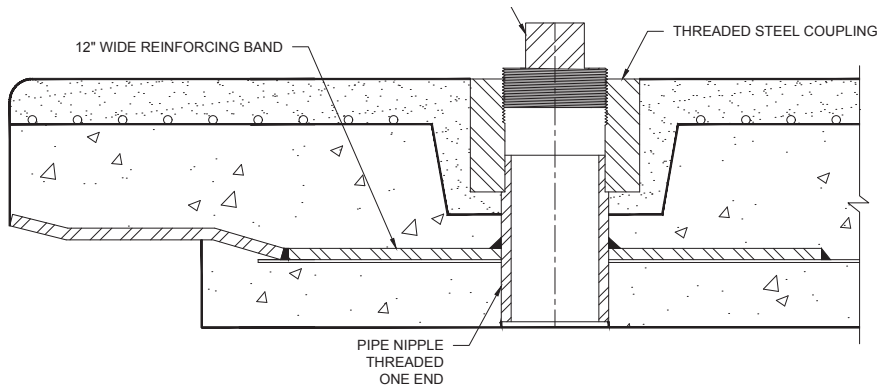

Determining outlet reinforcement

Outlet Diameter (inches)	Reinforcing Band Width (inches)	Working Pressure (pounds per square inch)	Maximum Pipe Diameter (inches) Reinforcing Band Thickness (inches)					
			3/16	1/4	5/16	3/8	7/16	1/2
3/4" - 3"	12	50	90	120	144			
		100	42	54	72	90	102	120
		150	24	36	42	60	66	78
		200	20	24	30	42	48	60

Access manholes can be furnished in all sizes of pipe over 30 inches in diameter. The elliptical opening provided is 16 inches by 18 inches. The manhole frame, cover, and arches are of cast steel. The cover is chained to the frame to prevent loss.

A boss is cast in the cover for a 2-inch or smaller threaded outlet, if it is necessary. Two arches, bolts, and nuts and one cover, gasket, and chain are furnished as a complete assembly.

Typical centerline outlet in lined cylinder pipe (L-301)

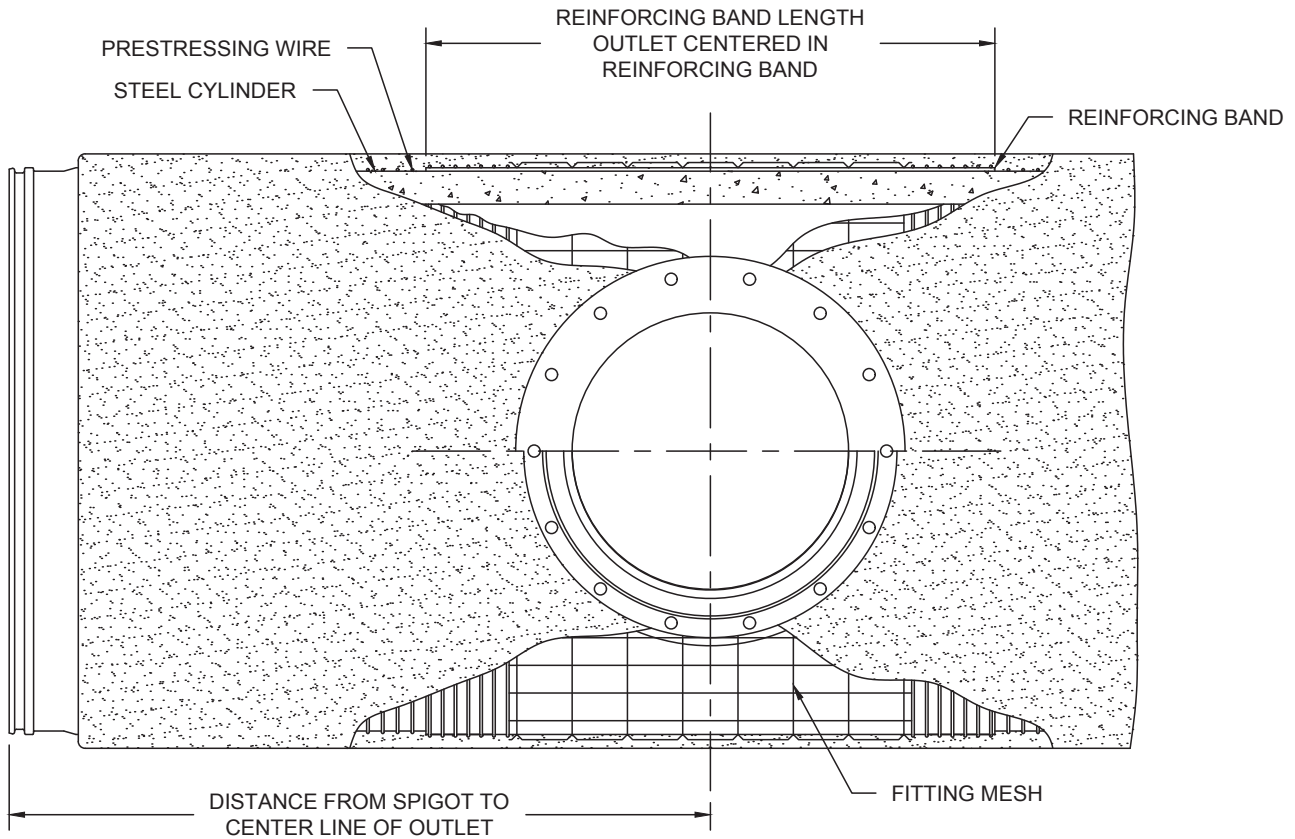

Note: The above view shows two styles of outlets: flanged (top half) and mechanical joint bell (bottom half).

Outlets can be furnished as:

- Bell
- Spigot
- Mechanical joint bell
- Mechanical joint spigot
- Flanged
- Victaulic

See Section 10 for details of end connections.

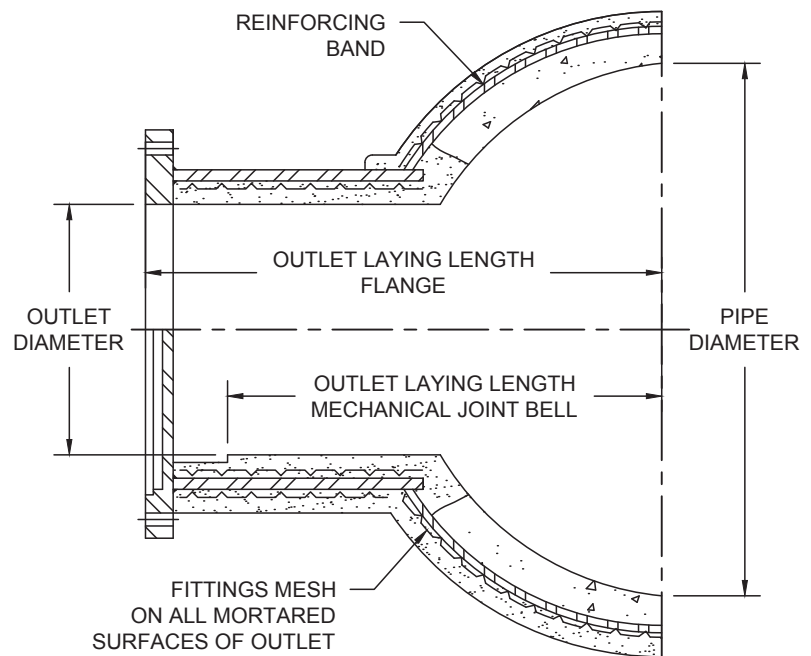

Note: The above view shows two styles of outlets: flanged (top half) and mechanical joint bell (bottom half).

Typical centerline outlet in lined cylinder pipe (L-301)

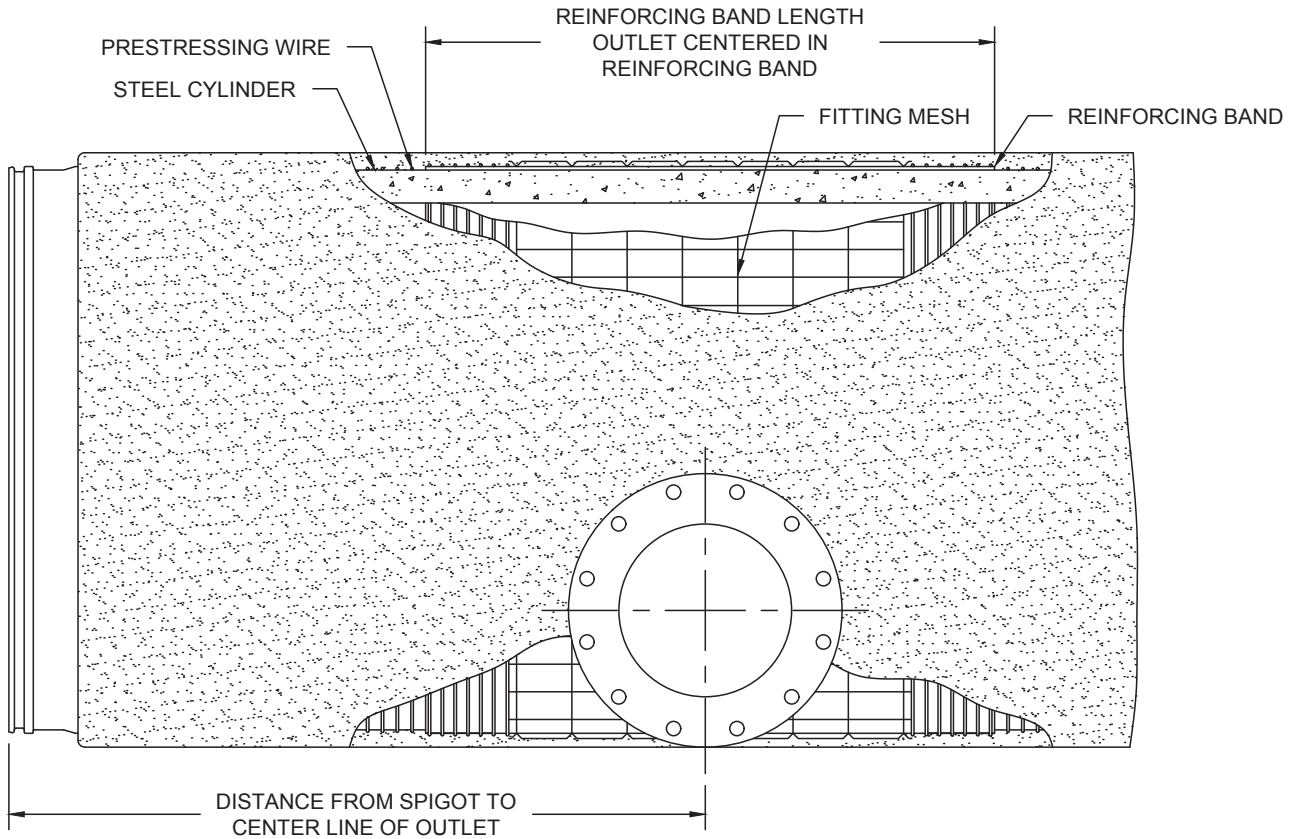

Note: The above view shows two styles of outlets: flanged (top half) and mechanical joint bell (bottom half).

Tangent outlets are most commonly flanges or mechanical joint bells, as shown here, but can be furnished with other end connections.

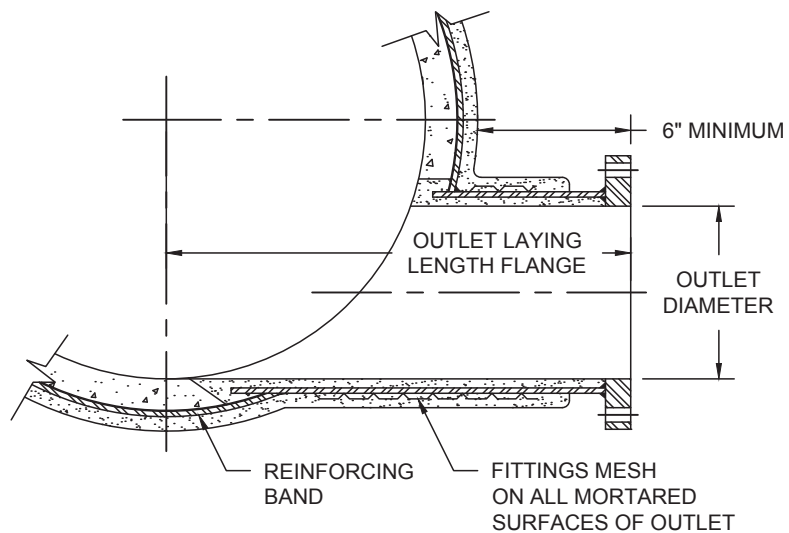

Note: The above view shows two styles of outlets: flanged (top half) and mechanical joint bell (bottom half).

OUTLET LAYING LENGTHS 4- TO 6-INCH DIAMETERS

Lined cylinder pipe

Pipe Diameter (inches)	Flange		Mechanical Joint				Tangent			
	4-inch	6-inch	4-inch	6-inch	4-inch	6-inch	4-inch	6-inch	4-inch	6-inch
	Slip-on (feet)		Spigot* (feet)		Bell (feet)		Mech. Joint Bell (feet)		Flange (feet)	
16	1.33	1.34	2.33		1.25	1.27	1.25	1.27	1.33	1.34
18	1.42	1.43	2.43		1.35	1.37	1.35	1.37	1.42	1.43
20	1.52	1.53	2.52		1.45	1.47	1.45	1.47	1.52	1.53
24	1.71	1.71	2.71		1.64	1.67	1.64	1.67	1.71	1.71
30	1.99	2.00	2.99		1.93	1.96	1.93	1.96	1.99	2.00
36	2.27	2.28	3.27		2.21	2.25	2.21	2.25	2.27	2.28
42	2.55	2.56	3.55		2.49	2.53	2.49	2.53	2.55	2.56
48	2.82	2.84	3.83		2.78	2.82	2.78	2.82	2.82	2.84

Embedded cylinder pipe

Pipe Diameter (inches)	Flange		Mechanical Joint				Tangent			
	4-inch	6-inch	4-inch	6-inch	4-inch	6-inch	4-inch	6-inch	4-inch	6-inch
	Slip-on (feet)		Spigot* (feet)		Bell (feet)		Mech. Joint Bell (feet)		Flange (feet)	
36	2.45	2.48	3.42		2.42	2.43	2.42	2.43	2.45	2.48
42	2.74	2.77	3.63		2.71	2.72	2.71	2.72	2.74	2.77
48	3.04	3.06	3.92		3.00	3.01	3.00	3.01	3.04	3.06
54	3.29	3.30	4.17		3.29	3.30	3.29	3.30	3.29	3.30
60	3.62	3.64	4.46		3.58	3.59	3.58	3.59	3.62	3.64
66	3.91	3.93	4.75		3.87	3.89	3.87	3.89	3.91	3.93
72	4.21	4.22	5.04		4.17	4.18	4.17	4.18	4.21	4.22
78	4.50	4.51	5.25		4.46	4.47	4.46	4.47	4.50	4.51
84	4.79	4.80	5.63		4.75	4.76	4.75	4.76	4.79	4.80
90	5.04	5.04	5.88		5.00	5.01	5.00	5.01	5.04	5.04
96	5.33	5.34	6.13		5.25	5.26	5.26	5.26	5.33	5.34

*Plain end same laying length as mechanical joint spigot

OUTLET LAYING LENGTHS 8- TO 10-INCH DIAMETERS

Lined cylinder pipe

Pipe Diameter (inches)	Flange		Mechanical Joint				Tangent			
	8-inch	10-inch	8-inch	10-inch	8-inch	10-inch	8-inch	10-inch	8-inch	10-inch
	Slip-on (feet)		Spigot* (feet)		Bell (feet)		Mech. Joint Bell (feet)		Flange (feet)	
16	1.36	1.40	2.33		1.30	1.32	1.30	1.32	1.36	1.40
18	1.45	1.49	2.43		1.41	1.44	1.41	1.44	1.45	1.49
20	1.55	1.58	2.52		1.52	1.55	1.52	1.55	1.55	1.58
24	1.72	1.77	2.71		1.72	1.77	1.72	1.77	1.72	1.77
30	2.02	2.05	2.99		2.02	2.07	2.02	2.07	2.02	2.05
36	2.30	2.33	3.27		2.31	2.37	2.31	2.37	2.30	2.33
42	2.58	2.62	3.55		2.60	2.66	2.60	2.66	2.58	2.62
48	2.87	2.90	3.83		2.89	2.95	2.89	2.95	2.87	2.90

Embedded cylinder pipe

Pipe Diameter (inches)	Flange		Mechanical Joint				Tangent			
	8-inch	10-inch	8-inch	10-inch	8-inch	10-inch	8-inch	10-inch	8-inch	10-inch
	Slip-on (feet)		Spigot* (feet)		Bell (feet)		Mech. Joint Bell (feet)		Flange (feet)	
36	2.51	2.56	3.42		2.47	2.47	2.51	2.56	2.45	2.48
42	2.80	2.85	3.63		2.76	2.76	2.80	2.85	2.74	2.77
48	3.09	3.14	3.92		3.05	3.05	3.09	3.14	3.04	3.06
54	3.32	3.36	4.17		3.34	3.34	3.32	3.36	3.29	3.30
60	3.66	3.69	4.46		3.64	3.64	3.66	3.69	3.62	3.64
66	3.95	3.98	4.75		3.93	3.93	3.95	3.98	3.91	3.93
72	4.24	4.27	5.04		4.22	4.22	4.24	4.27	4.21	4.22
78	4.53	4.56	5.25		4.51	4.51	4.53	4.56	4.50	4.51
84	4.82	4.85	5.63		4.80	4.80	4.82	4.85	4.79	4.80
90	5.07	5.10	5.88		5.05	5.05	5.07	5.10	5.04	5.04
96	5.36	5.39	6.13		5.30	5.30	5.36	5.39	5.33	5.34

*Plain end same laying length as mechanical joint spigot

OUTLET LAYING LENGTHS 12- TO 14-INCH DIAMETERS

Lined cylinder pipe

Pipe Diameter (inches)	Flange		Mechanical Joint				Tangent			
	12-inch	14-inch	12-inch	14-inch	12-inch	14-inch	12-inch	14-inch	12-inch	14-inch
	Class D (feet)		Spigot* (feet)	Bell (feet)		Mech. Joint Bell (feet)		Class D Flange (feet)		
16	1.40	1.45	2.33	1.33	1.28	1.33	-	-	-	
18	1.49	1.54	2.43	1.46	1.49	1.46	-	1.49	-	
20	1.58	1.64	2.52	1.59	1.64	1.59	-	1.58	1.64	
24	1.77	1.82	2.71	1.82	1.90	1.82	1.90	1.77	1.82	
30	2.05	2.10	2.99	2.13	2.24	2.13	2.24	2.05	2.10	
36	2.33	2.39	3.27	2.44	2.55	2.44	2.55	2.33	2.39	
42	2.62	2.67	3.55	2.73	2.86	2.73	2.86	2.62	2.67	
48	2.90	2.95	3.83	3.03	3.16	3.03	3.16	2.90	2.95	

Embedded cylinder pipe

Pipe Diameter (inches)	Flange		Mechanical Joint				Tangent			
	8-inch	10-inch	8-inch	10-inch	8-inch	10-inch	8-inch	10-inch	8-inch	10-inch
	Class D (feet)		Spigot* (feet)	Bell (feet)		Mech. Joint Bell (feet)		Class D Flange (feet)		
36	2.56	2.58	3.42	2.48	2.46	2.48	-	2.56	2.58	
42	2.85	2.87	3.63	2.77	2.74	2.77	-	2.85	2.87	
48	3.14	3.16	3.92	3.06	3.02	3.06	-	3.14	3.16	
54	3.36	3.41	4.17	3.35	3.31	3.35	-	3.36	3.41	
60	3.69	3.74	4.46	3.65	3.60	3.65	3.60	3.69	3.74	
66	3.98	4.03	4.75	3.94	3.90	3.94	3.90	3.98	4.03	
72	4.27	4.32	5.04	4.23	4.19	4.23	4.19	4.27	4.32	
78	4.56	4.61	5.25	4.52	4.48	4.52	4.48	4.56	4.61	
84	4.85	4.90	5.63	4.81	4.69	4.81	4.69	4.85	4.90	
90	5.10	5.15	5.88	5.06	5.02	5.06	5.02	5.10	5.15	
96	5.39	5.44	6.13	5.31	5.31	5.31	5.31	5.39	5.44	

*Plain end same laying length as mechanical joint spigot

OUTLET LAYING LENGTHS 16- TO 20-INCH DIAMETERS

Lined cylinder pipe

Pipe Diameter (inches)	Flange		Mechanical Joint				Tangent				Carnegie Joint			
	16-inch	20-inch	16-inch	20-inch	16-inch	20-inch	16-inch	20-inch	16-inch	20-inch	16-inch	20-inch	16-inch	20-inch
	Class D (feet)		Spigot* (feet)		Bell (feet)		Flange (feet)		Mech. Joint Bell (feet)		Spigot (feet)		Bell (feet)	
16	-	-	-	-	-	-	-	-	-	-	-	-	-	-
18	-	-	-	-	-	-	-	-	-	-	-	-	-	-
20	-	-	-	-	-	-	-	-	-	-	-	-	-	-
24	1.85	-	2.71	-	1.90	-	1.85	-	1.90	-	2.11	-	1.89	-
30	2.13	-	2.99	-	2.24	-	2.13	-	2.24	-	2.36	-	2.14	-
36	2.41	2.46	3.27	3.27	2.55	-	2.41	-	2.55	-	2.65	2.65	2.42	2.42
42	2.69	2.74	3.55	3.55	2.86	2.86	2.69	2.74	2.86	2.86	2.95	2.95	2.67	2.67
48	2.97	3.02	3.83	3.83	3.16	3.16	2.97	3.02	3.16	3.16	3.25	3.25	2.97	2.97

Embedded cylinder pipe

Pipe Diameter (inches)	Flange		Mechanical Joint				Tangent				Carnegie Joint			
	16-inch	20-inch	16-inch	20-inch	16-inch	20-inch	16-inch	20-inch	16-inch	20-inch	16-inch	20-inch	16-inch	20-inch
	125 Pound (feet)		Spigot* (feet)		Bell (feet)		Flange (feet)		Mech. Joint Bell (feet)		Spigot (feet)		Bell (feet)	
36	2.59	2.63	3.42	2.45	-	2.59	-	-	-	2.65	2.42			
42	2.89	2.93	3.63	2.74	2.75	2.89	2.93	-	-	2.95	2.67			
48	3.18	3.22	3.92	3.03	3.04	3.18	3.22	-	-	3.25	2.97			
54	3.43	3.49	4.17	3.32	3.33	3.43	3.49	-	-	3.52	3.29			
60	3.76	3.82	4.46	3.61	3.62	3.76	3.82	3.61	-	3.81	3.45			
66	4.05	4.11	4.75	3.91	3.92	4.05	4.11	3.91	-	4.23	3.84			
72	4.35	4.41	5.04	4.20	4.21	4.35	4.41	4.20	4.21	4.52	4.13			
78	4.64	4.70	5.25	4.49	4.50	4.64	4.70	4.49	4.50	4.81	4.41			
84	4.93	4.99	5.63	4.70	4.71	4.93	4.99	4.70	4.71	5.21	4.68			
90	5.18	5.24	5.88	5.03	5.04	5.18	5.24	5.03	5.04	5.47	5.05			
96	5.47	5.53	6.13	5.32	5.33	5.47	5.53	5.32	5.33	5.79	5.38			

*Plain end same laying length as mechanical joint spigot

OUTLET LAYING LENGTHS 24- TO 60-INCH DIAMETERS

Lined cylinder and embedded cylinder pipe

Pipe Diameter (inches)	Flange							Plain End		
	24-inch	30-inch	36-inch	42-inch (feet)	48-inch	54-inch	60-inch	24-inch	30-inch (feet)	36-inch
42	3.07	-	-	-	-	-	-	3.55	-	-
48	3.36	3.44	-	-	-	-	-	3.83	3.83	-
54	3.66	3.74	-	-	-	-	-	4.17	4.17	-
60	3.95	4.03	4.14	-	-	-	-	4.46	4.46	4.46
66	4.23	4.32	4.43	4.49	-	-	-	4.75	4.75	4.75
72	4.53	4.61	4.72	4.78	-	-	-	5.04	5.04	5.04
78	4.81	4.90	5.02	5.07	5.10	-	-	5.25	5.25	5.25
84	5.11	5.19	5.31	5.36	5.39	5.50	-	5.63	5.63	5.63
90	5.36	5.44	5.56	5.61	5.64	5.75	5.78	5.88	5.88	5.88
96	5.65	5.73	5.84	5.90	5.94	6.04	6.07	6.13	6.13	6.13

OUTLET LAYING LENGTHS 24- TO 60-INCH DIAMETERS

Lined cylinder and embedded cylinder pipe

Pipe Diameter (inches)	Maximum Outlet Diameter (inches)	Carnegie Spigot (feet)	Carnegie Bell (feet)
42	24	2.95	2.67
48	30	3.25	2.97
54	30	3.52	3.29
60	36	3.81	3.45
66	42	4.23	3.84
72	42	4.52	4.13
78	48	4.81	4.41
84	54	5.21	4.68
90	60	5.47	5.05
96	60	5.79	5.38

OUTLETS – REINFORCING BAND THICKNESS AND WIDTH

Lined cylinder pipe

Pipe Diameter (inches)	Working Pressure (pounds per square inch)	Maximum Outlet Diameter (inches)	Outlet Diameter (inches)											
			4	6	8	10	12	14	16	18	20	24	30	
			Reinforcing Band Width (inches)											
			18	22	26	30	34	40	44	48	53	62	74	
16	100	12	← 3/16 →				-	-	-	-	-	-	-	-
	150		← 3/16 →				-	-	-	-	-	-	-	-
	200		← 3/16 →				-	-	-	-	-	-	-	-
18	100	12	← 3/16 →				-	-	-	-	-	-	-	
	150		← 3/16 →				-	-	-	-	-	-	-	
	200		← 3/16 →				-	-	-	-	-	-	-	
20	100	14	← 3/16 →					-	-	-	-	-	-	
	150		← 3/16 →					-	-	-	-	-	-	
	200		← 3/16 →					-	-	-	-	-	-	
24	100	16	← 3/16 →						-	-	-	-		
	150		← 3/16 →						-	-	-	-		
	200		← 1/4 →						-	-	-	-		
30	100	18	← 3/16 →							-	-	-		
	150		← 1/4 →							-	-	-		
	200		← 5/16 →							-	-	-		
36	100	20	← 3/16 →								-	-		
	150		← 1/4 →								-	-		
	200		← 3/8 →								-	-		
42	100	24	← 3/16 →									-		
	150		← 5/16 →									-		
	200		← 3/8 →									-		
48	100	30	← 1/4 →											
	150		← 3/8 →											
	200		← 7/16 →											

OUTLETS – REINFORCING BAND THICKNESS AND WIDTH

Embedded cylinder pipe

Pipe Diameter (inches)	Working Pressure (pounds per square inch)	Maximum Outlet Diameter (inches)	Outlet Diameter (inches)																
			4	6	8	10	12	14	16	18	20	24	30	36	42	48	54	60	
			Reinforcing Band Width (inches)																
			18	22	26	30	34	40	44	48	53	62	74	87	101	114	120	132	
36	100	20	←----- 3/16 ----->										-	-	-	-	-	-	-
	150		←----- 1/4 ----->										-	-	-	-	-	-	-
	200		←----- 3/8 ----->										-	-	-	-	-	-	-
42	100	24	←----- 3/16 ----->										-	-	-	-	-	-	
	150		←----- 5/16 ----->										-	-	-	-	-	-	
	200		←----- 3/8 ----->										-	-	-	-	-	-	
48	100	30	←----- 1/4 ----->										-	-	-	-	-		
	150		←----- 3/8 ----->										-	-	-	-	-		
	200		←----- 7/16 ----->										-	-	-	-	-		
54	50	30	←----- 3/16 ----->										-	-	-	-	-		
	100		←----- 1/4 ----->										-	-	-	-	-		
	150		←----- 3/8 ----->										-	-	-	-	-		
	200		←----- 1/2 ----->										-	-	-	-	-		
60	50	36	←----- 3/16 ----->										-	-	-	-			
	100		←----- 5/16 ----->										-	-	-	-			
	150		←----- 3/8 ----->										-	-	-	-			
	200		←----- 1/2 ----->										-	-	-	-			
66	50	42	←----- 3/16 ----->										-	-	-				
	100		←----- 5/16 ----->										-	-	-				
	150		←----- 7/16 ----->										-	-	-				
	200		←----- 9/16 ----->										-	-	-				
72	50	42	←----- 3/16 ----->										-	-	-				
	100		←----- 5/16 ----->										-	-	-				
	150		←----- 1/2 ----->										-	-	-				
	200		←----- 5/8 ----->										-	-	-				
78	50	48	←----- 3/16 ----->										-	-					
	100		←----- 3/8 ----->										-	-					
	150		←----- 9/16 ----->										-	-					
84	50	54	←----- 3/16 ----->										-						
	100		←----- 3/8 ----->										-						
	150		←----- 9/16 ----->										-						
90	50	60	←----- 1/4 ----->										-						
	100		←----- 3/4 ----->										-						
	150		←----- 9/16 ----->										-						
96	50	60	←----- 1/4 ----->										-						
	100		←----- 7/16 ----->										-						
	150		←----- 5/8 ----->										-						



ELBOWS

Elbows can be used where it is impractical to make long radius curves with deflected straight or bevel pipe. Dimensions for elbows of standard laying length and radius are tabulated in this section. However, as standard practice, Thompson Pipe Group can fabricate elbows to other dimensions and deflection angles.

Joint openings and bevel pipe or bevel adapters (see Section Five) may be used in conjunction with the elbows to adjust the specified angle.

The approximate laying lengths for elbows of intermediate deflection can be obtained by interpolation of the standard elbow laying length tables in this section.

Prefabricated, large diameter elbows can be supplied but may be limited by shipping dimensions or weight. When these limitations occur, the required deflection may be obtained by the use of two or three elbows with smaller deflections.

Standard Elbow

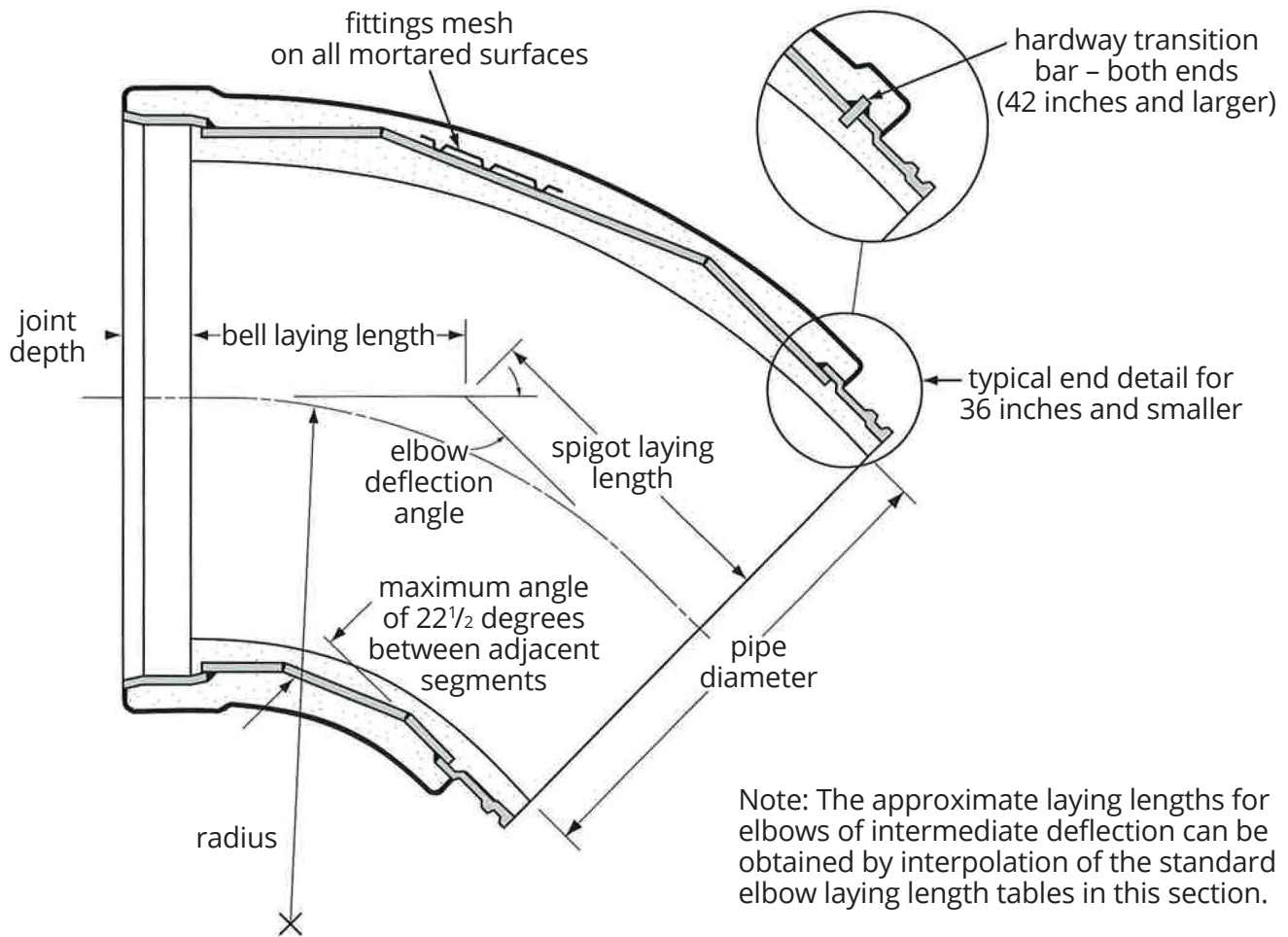

ROTATION OF ELBOWS AND COMBINED BENDS

By rotating an elbow, it is possible to obtain a simultaneous horizontal and vertical deflection by what is known as a combined bend.

Formulas are given below for computing the manufactured angle of elbows in terms of their combined horizontal and vertical deflections, and for determining their degree of rotation required in order to obtain required deflections. The latter formula can also be applied to the location of lugs on elbow joints.

DETERMINING THE MANUFACTURED ANGLE

The manufactured angle of a combined bend can be determined from:

$$\cos C = (\cos H \cos V \cos V') + (\sin V \sin V')$$

The rotation of an elbow to obtain the required horizontal and vertical deflections can be determined from:

$$\sin S = \frac{(\sin V \cos C) - (\sin V')}{(\cos V \sin C)}$$

$$\sin B = \frac{\sin V' \cos C - (\sin V)}{(\cos V' \sin C)}$$

Where:

- C = Manufactured angle of elbow (deflection angle in plane of elbow)
- H = Horizontal projection of deflection angle of bend
- V = Vertical angle of approaching line (near end) with horizontal plane
- V' = Vertical angle of departing line (far end) with horizontal plane
- S = Required rotation from the horizontal of elbow at near end
- B = Required rotation from the horizontal of elbow at far end

Note: V and V' are positive or negative if the pipe is sloping upward or downward, respectively, in the direction of laying. For V and V' positive, SinV or V' and CosV or V' are positive. For V or V' negative, SinV or V' is negative, and CosV or V' is positive

Elbow Rotation

Looking at the spigot end, measure rotation distance X around the spigot ring from the long side (LS) mark; clockwise for vertical up, counter-clockwise for vertical down. Rotate elbow until point A is at the horizontal springline. X dimension is indicated on the laying schedule.

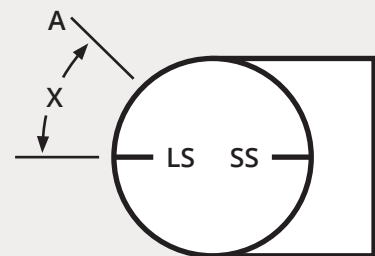

APPROXIMATE ELBOW LAYING LENGTHS

Elbow Angle		11¼ degrees		22½ degrees		30 degrees		45 degrees		60 degrees		90 degrees	
Pipe Diameter (inches)	Elbow Radius (inches)	Spigot LL (feet)	Bell LL (feet)	Spigot LL (feet)	Bell LL (feet)	Spigot LL (feet)	Bell LL (feet)	Spigot LL (feet)	Bell LL (feet)	Spigot LL (feet)	Bell LL (feet)	Spigot LL (feet)	Bell LL (feet)
16	24	0.66	0.26	0.86	0.46	0.99	0.60	1.29	0.89	1.61	1.22	2.46	2.06
18	26	0.67	0.28	0.89	0.49	1.04	0.64	1.36	0.96	1.71	1.31	2.62	2.23
20	28	0.69	0.29	0.92	0.53	1.08	0.69	1.42	1.03	1.81	1.41	2.79	2.40
24	30	0.70	0.31	0.96	0.56	1.13	0.73	1.49	1.10	1.90	1.51	2.96	2.56
30	34	0.74	0.34	1.02	0.63	1.22	0.82	1.63	1.24	2.09	1.70	3.29	2.90
36	38	0.77	0.37	1.09	0.69	1.31	0.91	1.77	1.37	2.29	1.89	3.62	3.23
42	42	0.88	0.54	1.23	0.89	1.47	1.14	1.98	1.65	2.55	2.22	4.03	3.70
48	48	0.93	0.59	1.33	0.99	1.60	1.27	2.19	1.85	2.84	2.51	4.53	4.20
54	54	1.08	0.63	1.53	1.08	1.84	1.39	2.50	2.05	3.23	2.79	5.14	4.69
60	60	1.14	0.69	1.64	1.19	1.99	1.54	2.72	2.27	3.53	3.08	5.65	5.20
66	66	1.21	0.74	1.76	1.29	2.14	1.67	2.94	2.48	3.84	3.37	6.17	5.70
72	72	1.26	0.78	1.86	1.38	2.27	1.80	3.15	2.67	4.13	3.65	6.67	6.19
78	78	1.31	0.82	1.96	1.47	2.41	1.92	3.36	2.87	4.42	3.93	7.17	6.68
84	84	1.36	0.86	2.06	1.56	2.54	2.04	3.57	3.07	4.71	4.21	7.67	7.17
90	90	1.43	0.92	2.18	1.67	2.70	2.19	3.79	3.28	5.02	4.51	8.19	7.68
96	96	1.48	0.97	2.28	1.77	2.83	2.32	4.00	3.49	5.31	4.80	8.69	8.18

- Notes :
1. Elbows 42 inches and larger may be manufactured with a transition bar at each end.
 2. Laying lengths for elbows may vary slightly dependent on pipe type and laying lengths for elbows larger than 96 inches are available upon request.
 3. Commonly used angles are listed in this table. Elbows of any degree plus or minus ½ degree are available.
 4. These laying lengths are based upon the use of Snap Ring® joints for diameters 16-inch through 60-inch and Harness Clamp joints for diameters 66-inch through 96-inch.
 5. Elbow legs may be extended to eliminate the need for a stationing short.

ELBOW CYLINDER THICKNESS

Pipe Diameter (inches)	Working Pressure (pounds per square inch)				Pipe Diameter (inches)	Working Pressure (pounds per square inch)			
	50	100	150	200		50	100	150	200
	Steel Cylinder Thickness (inches)					Steel Cylinder Thickness (inches)			
16	3/16	3/16	3/16	3/16	54	5/16	5/16	1/2	5/8
18	3/16	3/16	3/16	3/16	60	5/16	3/8	1/2	3/4
20	3/16	3/16	3/16	1/4	66	3/8	3/8	5/8	3/4
24	3/16	3/16	3/16	5/16	72	3/8	7/16	5/8	7/8
30	3/16	3/16	5/16	3/8	78	7/16	7/16	3/4	7/8
36	3/16	1/4	3/8	7/16	84	7/16	1/2	3/4	1
42	1/4	5/16	7/16	5/8	90	1/2	1/2	3/4	1
48	1/4	5/16	1/2	5/8	96	1/2	5/8	7/8	1-1/8

Note: Elbow cylinder thicknesses and lay lengths listed above based on standard elbow radii supplied by Thompson Pipe Group.



TEES, WYES, AND CROSSES

Tables for laying lengths of tees and wyes are included in the following pages.

Information in these tables includes both approximate run and branch laying lengths for various types of joints with run diameters from 16 inches to 96 inches. Types of joints other than those tabulated here are available and additional information on larger diameters can be obtained from Thompson Pipe Group.

Small diameter tees can be manufactured without crotch plates by using a collar or wrapper or a thicker steel cylinder for the "run." A drawing of this type of tee is shown on the next page.

TEE WITH CROTCH PLATES

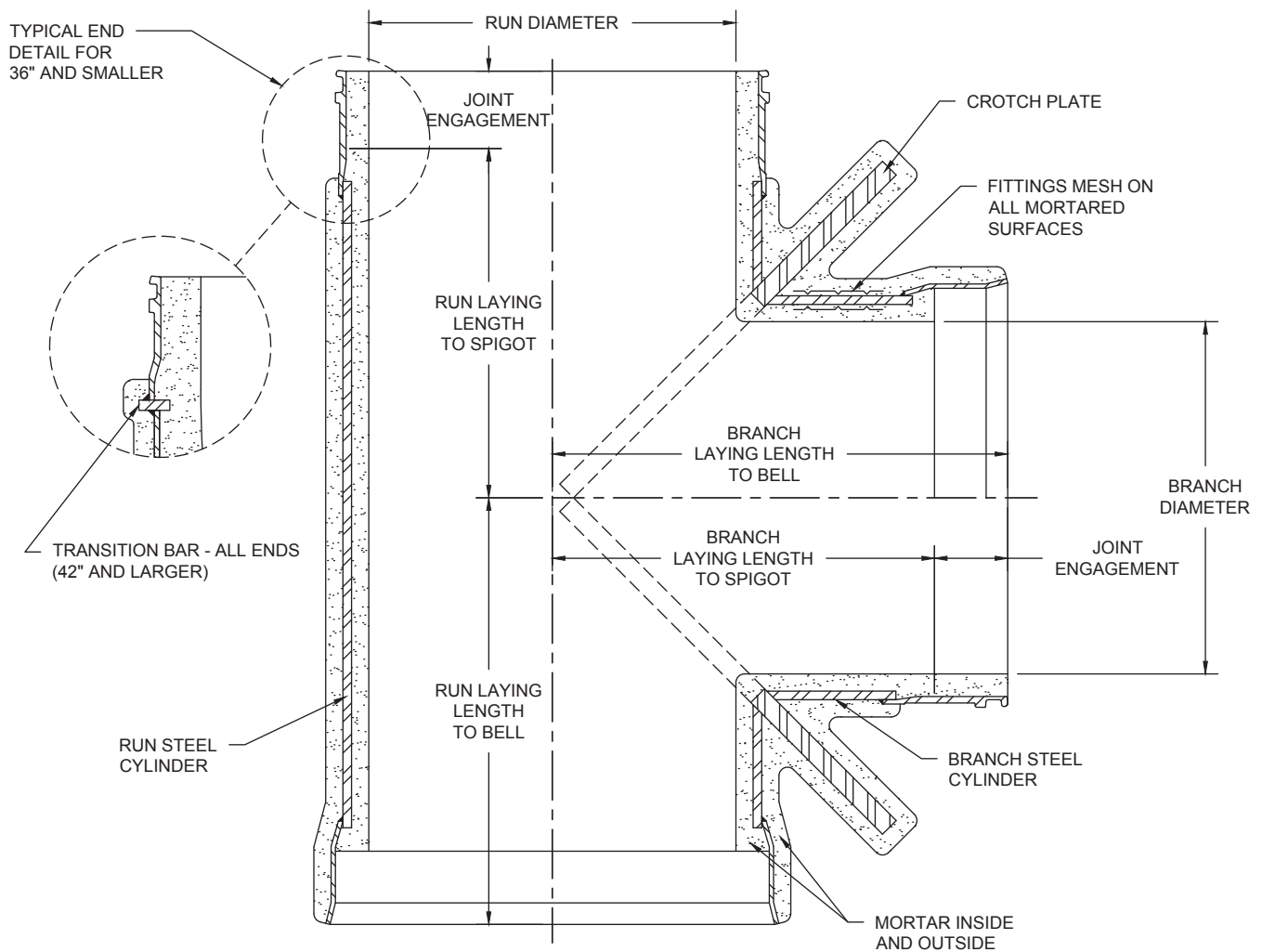

TEE WITHOUT CROTCH PLATES

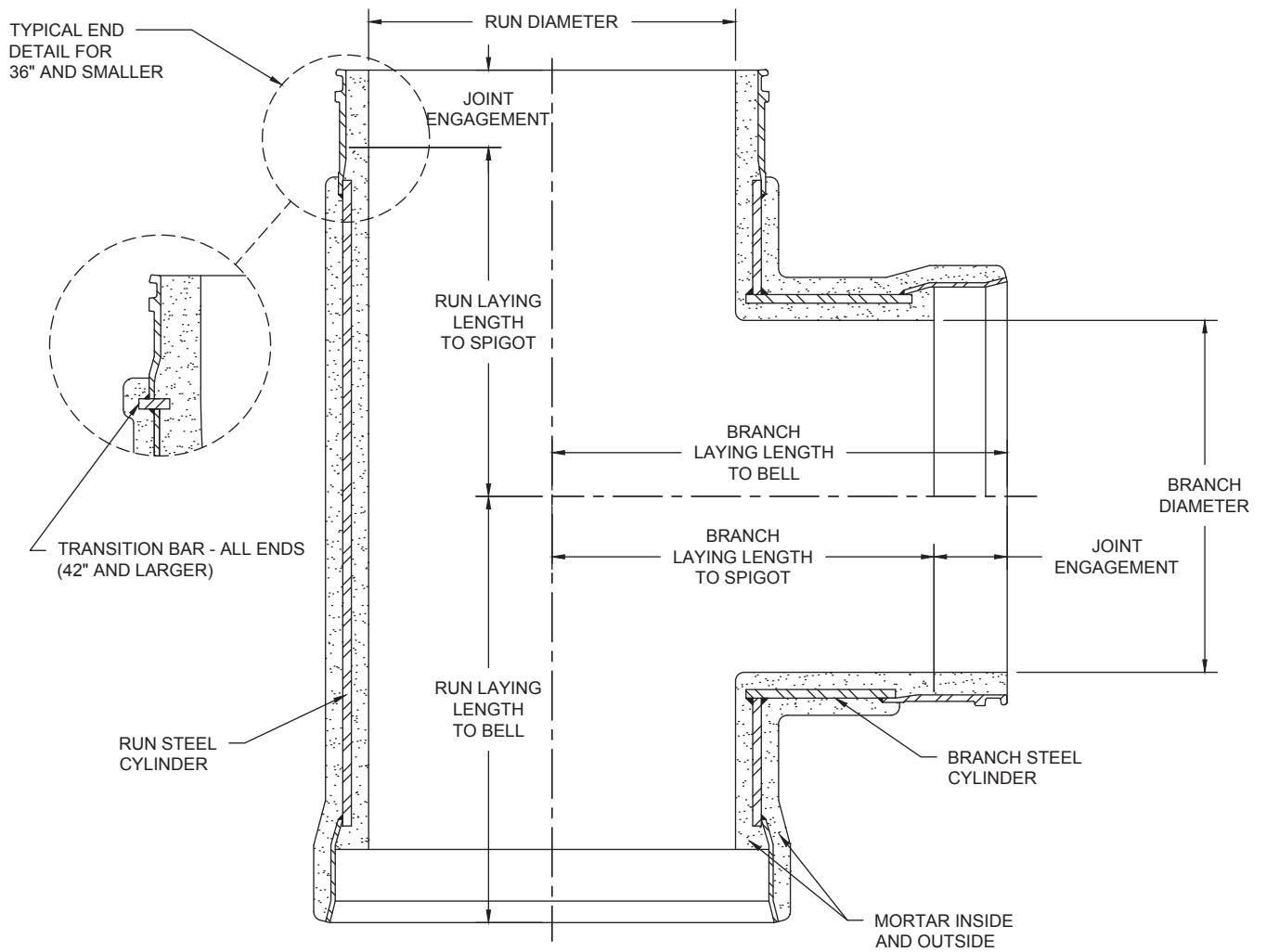

TEE LAYING LENGTHS 16-INCH TO 60-INCH DIAMETER

Diameter		Run Laying Length				Branch Laying Length			
Run (inches)	Branch (inches)	Carnegie Spigot (feet)	Carnegie Bell (feet)	Flange (feet)	Mechanical Joint Bell (feet)	Carnegie Spigot (feet)	Carnegie Bell (feet)	Flange (feet)	Mechanical Joint Bell (feet)
16	16	2.46	2.08	3.04	2.69	2.21	1.83	2.76	2.44
18	18	2.46	2.08	3.04	2.69	2.30	1.93	2.85	2.53
	16	2.46	2.08	3.04	2.69	2.30	1.93	2.90	2.53
20	20	2.46	2.08	3.05	2.70	2.40	2.02	2.95	2.64
	18	2.46	2.08	3.05	2.70	2.40	2.02	2.99	2.63
	16	2.46	2.08	3.05	2.70	2.40	2.02	2.99	2.63
24	24	2.96	2.58	3.56	3.20	2.58	2.21	3.19	2.83
	20	2.46	2.08	3.06	2.70	2.58	2.21	3.18	2.83
	18	2.46	2.08	3.06	2.70	2.58	2.21	3.18	2.82
30	30	2.96	2.58	3.57	3.18	2.86	2.49	3.48	3.09
	24	2.96	2.58	3.57	3.18	2.86	2.49	3.47	3.11
	20	2.46	2.08	3.07	2.68	2.86	2.49	3.46	3.11
36	36	3.46	3.08	4.09	3.70	3.15	2.77	3.78	3.39
	30	2.96	2.58	3.59	3.20	3.15	2.77	3.76	3.37
	24	2.96	2.58	3.59	3.20	3.15	2.77	3.75	3.39
42	42	3.53	3.16	4.10	3.70	3.50	3.13	4.07	3.67
	36	3.53	3.16	4.10	3.70	3.43	3.05	4.06	3.67
	30	3.03	2.66	3.60	3.20	3.43	3.05	4.04	3.65
48	48	4.03	3.66	4.63	4.20	3.78	3.41	4.38	3.95
	42	3.53	3.16	4.13	3.70	3.78	3.41	4.35	3.95
	36	3.53	3.16	4.13	3.70	3.71	3.33	4.34	3.95
54	54	4.14	3.69	4.88	-	4.01	3.56	4.47	-
	48	4.14	3.69	4.88	-	3.90	3.53	4.49	4.07
	42	3.64	3.19	4.38	-	3.90	3.53	4.47	4.07
	36	3.64	3.19	4.38	-	3.83	3.45	4.46	4.07
60	60	4.65	4.19	5.40	-	4.27	3.90	4.98	-
	54	4.15	3.69	4.90	-	4.26	3.81	4.73	-
	48	4.15	3.69	4.90	-	4.16	3.78	4.75	4.33
	42	3.65	3.19	4.40	-	4.16	3.78	4.73	4.33

TEE LAYING LENGTHS

66-INCH TO 96-INCH DIAMETER

Diameter		Run Laying Length				Branch Laying Length			
Run (inches)	Branch (inches)	Carnegie Spigot (feet)	Carnegie Bell (feet)	Flange (feet)	Mechanical Joint Bell (feet)	Carnegie Spigot (feet)	Carnegie Bell (feet)	Flange (feet)	Mechanical Joint Bell (feet)
66	66	4.67	4.29	5.44	-	4.55	4.17	5.33	-
	60	4.67	4.28	5.44	-	4.53	4.16	5.29	-
	54	4.17	3.78	4.94	-	4.52	4.07	5.27	-
	48	4.17	3.78	4.94	-	4.42	4.01	5.02	4.59
72	72	5.17	4.77	5.95	-	4.81	4.42	5.60	-
	66	4.67	4.27	5.45	-	4.81	4.43	5.59	-
	60	4.67	4.27	5.45	-	4.79	4.42	5.55	-
	54	4.17	3.77	4.95	-	4.78	4.33	5.53	-
	48	4.17	3.77	4.95	-	4.68	4.27	5.28	4.85
78	78	5.17	4.76	5.96	-	5.07	4.66	5.86	-
	72	5.17	4.76	5.96	-	5.07	4.67	5.85	-
	66	4.67	4.26	5.46	-	5.07	4.68	5.84	-
	60	4.67	4.26	5.46	-	5.05	4.65	5.80	-
	54	4.17	3.76	4.96	-	5.04	4.59	5.78	-
84	84	5.67	5.25	6.46	-	5.33	4.91	6.12	-
	78	5.17	4.75	5.96	-	5.33	4.92	6.12	-
	72	5.17	4.75	5.96	-	5.33	4.93	6.11	-
	66	4.67	4.25	5.46	-	5.33	4.94	6.10	-
	60	4.67	4.25	5.46	-	5.31	4.93	6.06	-
90	90	5.69	5.26	6.50	-	5.60	5.18	6.42	-
	84	5.69	5.26	6.50	-	5.58	5.17	6.38	-
	78	5.19	4.76	6.00	-	5.58	5.18	6.38	-
	72	5.19	4.76	6.00	-	5.58	5.19	6.37	-
	66	4.69	4.26	5.50	-	5.58	5.20	6.36	-
96	96	6.18	5.76	7.00	-	5.86	5.43	6.68	-
	90	5.69	5.26	6.50	-	5.86	5.44	6.68	-
	84	5.69	5.26	6.50	-	5.84	5.43	6.64	-
	78	5.19	4.76	6.00	-	5.84	5.44	6.64	-
	72	5.19	4.76	6.00	-	5.84	5.45	6.63	-
	66	4.69	4.26	5.50	-	5.84	5.46	6.62	-

TEES AND CROSSES - CYLINDER THICKNESS

With crotch plates

Run or Branch Diameter (inches)	Working Pressure (pounds per square inch)			
	50	100	150	200
	Steel Cylinder Thickness (inches)			
16	3/16	3/16	3/16	3/16
18	3/16	3/16	3/16	3/16
20	3/16	3/16	3/16	3/16
24	3/16	3/16	3/16	1/4
30	3/16	3/16	3/16	5/16
36	3/16	3/16	1/4	3/8
42	1/4	1/4	1/4	3/8
48	1/4	1/4	5/16	7/16
54	5/16	5/16	3/8	1/2
60	5/16	5/16	3/8	1/2
66	3/8	3/8	7/16	9/16
72	3/8	3/8	1/2	5/8
78	7/16	7/16	1/2	3/4
84	7/16	7/16	9/16	3/4
90	1/2	1/2	9/16	3/4
96	1/2	1/2	5/8	7/8

Without crotch plates

Run or Branch Diameter (inches)	Working Pressure (pounds per square inch)			
	50	100	150	200
	Steel Cylinder Thickness (inches)			
16	3/16	3/16	1/4	5/16
18	3/16	3/16	1/4	3/8
20	3/16	3/16	5/16	3/8
24	3/16	1/4	3/8	1/2
30	3/16	3/8	5/8	*
36	1/4	1/2	*	*

*Use crotch plates.

The tables for wyes cover 45-degree branch wyes only. Information on other angles is available from Thompson Pipe Group. Tees and wyes are described in the following manner: run by run by branch. For example, a 60-inch, 45-degree wye with a spigot and bell and a 48-inch bell on the branch of the wye, would be described as a 60-inch spigot by 60-inch bell by 48-inch bell 45-degree branch wye.

The information on crosses is not detailed specifically in this manual. For laying purposes, crosses may be considered basically as double tees, and the tee laying lengths can therefore be used for specifying crosses. The additional branch on a cross has an additional laying length equal to a tee branch using the same type of joint.

To find wye cylinder thicknesses, refer to the table for tees and crosses with crotch plates, found on page 8.5.

45-DEGREE BRANCH WYE

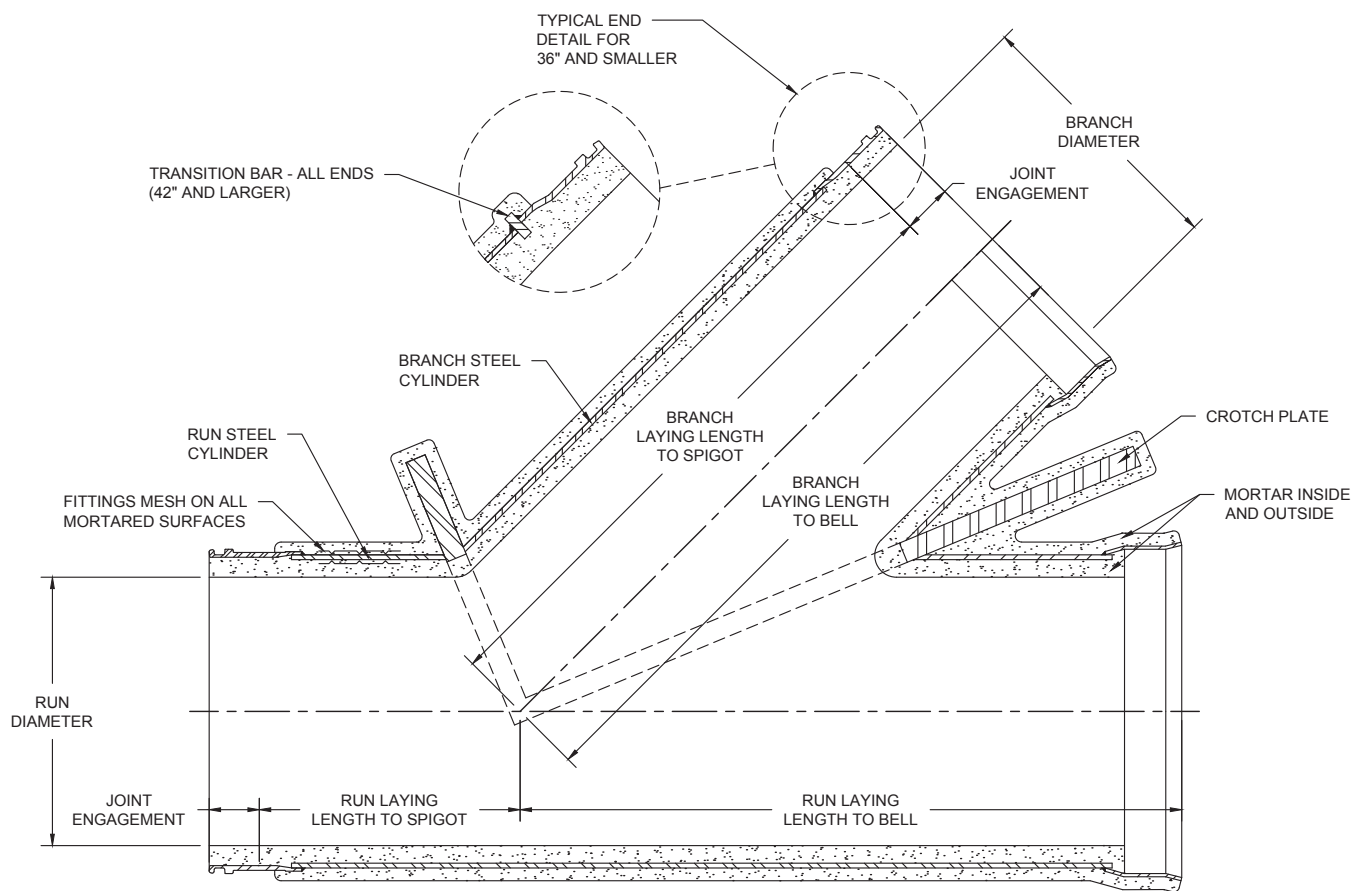

WYE LAYING LENGTHS

16-INCH TO 24-INCH DIAMETERS

Run Diameter (inches)	Segment	Branch Diameter (inches)	Carnegie Bell (feet)	Carnegie Spigot (feet)	Flange (feet)	Mechanical Joint Spigot (feet)	Mechanical Joint Bell (feet)
16	A	16	1.61	1.84	2.59	2.96	2.32
	B	16	3.61	3.84	4.59	4.96	4.32
	C	16	3.11	3.34	4.09	4.46	3.82
18	A	18	1.61	1.84	2.59	2.96	2.32
		16	1.64	1.84	2.59	2.96	2.32
	B	18	3.61	3.84	4.59	4.96	4.32
		16	3.61	3.84	4.59	4.96	4.32
	C	18	4.11	4.34	5.05	5.46	4.82
		16	3.11	3.34	4.05	4.46	3.82
20	A	20	1.61	1.84	2.56	2.96	2.33
		18	1.61	1.84	2.56	2.96	2.33
		16	1.61	1.84	2.56	2.96	2.33
	B	20	3.61	3.84	4.56	4.96	4.33
		18	3.61	3.84	4.56	4.96	4.33
		16	3.61	3.84	4.56	4.96	4.33
	C	20	4.11	4.34	5.05	5.46	4.82
		18	4.11	4.34	5.05	5.46	4.82
		16	4.11	4.34	5.05	5.46	4.82
24	A	24	2.11	2.34	3.10	3.50	2.83
		20	2.11	2.34	3.10	3.50	2.83
		18	2.11	2.34	3.10	3.50	2.83
		16	2.11	2.34	3.10	3.50	2.83
	B	24	4.11	4.34	5.10	5.50	4.83
		20	4.11	4.34	5.10	5.50	4.83
		18	4.11	4.34	5.10	5.50	4.83
		16	4.11	4.34	5.10	5.50	4.83
	C	24	4.11	4.34	5.10	5.50	4.83
		20	4.11	4.34	5.06	5.46	4.83
		18	4.11	4.34	5.05	5.46	4.82
		16	4.11	4.34	5.05	5.46	4.82

WYE LAYING LENGTHS

30-INCH & 36-INCH DIAMETERS

Run Diameter (inches)	Segment	Branch Diameter (inches)	Carnegie Bell (feet)	Carnegie Spigot (feet)	Flange (feet)	Mechanical Joint Spigot (feet)	Mechanical Joint Bell (feet)
30	A	30	2.11	2.34	3.11	3.50	2.81
		24	2.11	2.34	3.11	3.50	2.81
		20	2.11	2.34	3.11	3.50	2.81
		18	2.11	2.34	3.11	3.50	2.81
		16	2.11	2.34	3.11	3.50	2.81
	B	30	5.11	5.34	6.11	6.50	5.81
		24	5.11	5.34	6.11	6.50	5.81
		20	5.11	5.34	6.11	6.50	5.81
		18	5.11	5.34	6.11	6.50	5.81
		16	4.11	4.34	5.11	5.50	4.81
	C	30	5.11	5.34	6.11	6.50	5.81
		24	4.11	4.34	5.10	5.50	4.83
		20	4.11	4.34	5.06	5.46	4.83
		18	4.11	4.34	5.05	5.46	4.82
		16	4.11	4.34	5.05	5.46	4.82
36	A	36	2.09	2.33	3.13	3.50	2.83
		30	2.10	2.34	3.13	3.50	2.83
		24	1.60	1.84	2.63	3.00	2.33
		20	1.60	1.84	2.63	3.00	2.33
		18	1.60	1.84	2.63	3.00	2.33
	B	36	6.09	6.33	7.13	7.50	6.83
		30	6.10	6.34	7.13	7.50	6.83
		24	5.60	5.84	6.52	7.00	6.33
		20	5.60	5.84	6.53	7.00	6.33
		18	5.60	5.84	6.52	7.00	6.33
	C	36	6.09	6.33	7.03	7.50	6.83
		30	5.11	5.34	6.11	6.50	5.81
		24	5.11	5.34	6.13	6.50	5.83
		20	5.11	5.34	6.10	6.46	5.83
		18	5.11	5.34	6.10	6.46	5.82
16	4.11	4.34	5.09	5.46	4.82		

WYE LAYING LENGTHS

42-INCH & 48-INCH DIAMETERS

Run Diameter (inches)	Segment	Branch Diameter (inches)	Carnegie Bell (feet)	Carnegie Spigot (feet)	Flange (feet)	Mechanical Joint Spigot (feet)	Mechanical Joint Bell (feet)
42	A	42	2.07	2.47	3.15	4.00	2.79
		36	2.10	2.46	3.15	4.00	2.79
		30	1.61	1.97	2.65	3.50	2.29
		24	1.11	1.47	2.15	3.00	1.79
		20	1.11	1.47	2.15	3.00	1.79
		18	1.11	1.47	2.15	3.00	1.79
	B	42	7.07	7.47	8.15	9.00	7.79
		36	7.10	7.46	8.15	9.00	7.79
		30	6.61	6.97	7.65	8.50	7.29
		24	6.11	6.47	7.15	8.00	6.79
		20	6.11	6.47	7.15	8.00	6.79
		18	6.11	6.47	7.15	8.00	6.79
	C	42	7.07	7.43	8.15	9.00	7.83
		36	6.09	6.33	7.13	7.50	6.83
		30	6.10	6.34	7.11	7.50	6.81
		24	5.11	5.34	6.10	6.50	5.83
		20	5.11	5.34	6.05	6.50	5.83
		18	5.11	5.34	6.05	6.50	5.83
48	A	48	2.31	2.71	3.42	4.25	3.04
		42	2.31	2.72	3.42	4.25	3.04
		36	1.47	1.84	2.55	3.38	2.17
		30	1.48	1.85	2.55	3.38	2.17
		24	1.10	1.47	2.17	3.00	1.79
		20	1.10	1.47	2.17	3.00	1.79
	B	48	6.81	7.21	7.92	8.75	7.58
		42	6.81	7.22	7.92	8.75	7.58
		36	6.71	7.08	7.79	8.62	7.41
		30	6.72	7.09	7.79	8.62	7.41
		24	6.10	6.47	7.17	8.00	6.79
		20	6.10	6.47	7.17	8.00	6.79
	C	48	7.10	7.42	8.17	9.00	7.83
		42	7.07	7.43	8.14	9.00	7.83
		36	6.09	6.33	7.12	7.50	6.83
		30	6.11	6.34	7.11	7.50	6.81
		24	6.11	6.34	7.13	7.50	6.83
		20	6.11	6.34	7.13	7.50	6.83

WYE LAYING LENGTHS

54-INCH & 60-INCH DIAMETERS

Run Diameter (inches)	Segment	Branch Diameter (inches)	Carnegie Bell (feet)	Carnegie Spigot (feet)	Flange (feet)	Mechanical Joint Spigot (feet)	Mechanical Joint Bell (feet)
54	A	54	2.61	3.06	3.68	4.50	-
		48	2.58	3.06	3.68	4.50	-
		42	2.58	3.07	3.68	4.50	-
		36	1.61	2.06	2.68	3.50	-
		30	1.62	2.07	2.68	3.50	-
		24	1.12	1.57	2.18	3.00	-
	B	54	7.61	8.06	8.68	9.50	-
		48	7.58	8.06	8.68	9.50	-
		42	7.58	8.07	8.68	9.50	-
		36	7.61	8.06	8.68	9.50	-
		30	7.62	8.07	8.68	9.00	-
		24	6.12	6.57	7.18	8.00	-
	C	54	7.11	7.56	8.18	9.00	-
		48	7.10	7.42	8.17	9.00	7.83
		42	7.07	7.43	8.14	9.00	7.83
		36	7.09	7.33	8.12	8.50	6.83
		30	6.11	6.34	7.11	7.50	6.81
		24	6.11	6.34	7.13	7.50	6.83
60	A	60	3.09	3.56	4.19	5.00	-
		54	3.21	3.56	4.19	5.00	-
		48	2.18	2.56	3.19	4.00	-
		42	2.18	2.57	3.19	4.00	-
		36	2.21	2.56	3.19	4.00	-
		30	1.72	2.07	2.69	3.50	-
	B	60	8.09	8.56	9.19	10.00	-
		54	8.21	8.56	9.19	10.00	-
		48	8.18	8.56	9.19	10.00	-
		42	8.18	8.57	9.19	10.00	-
		36	8.21	8.56	9.19	10.00	-
		30	7.72	8.07	8.69	9.50	-
	C	60	8.09	8.56	9.19	10.00	-
		54	8.11	8.56	9.18	10.00	-
		48	8.10	8.42	9.17	10.00	8.83
		42	7.07	7.43	8.14	9.00	7.83
		36	7.09	7.33	8.12	8.50	7.83
		30	7.11	7.34	8.11	8.50	7.81

WYE LAYING LENGTHS

66-INCH & 72-INCH DIAMETERS

Run Diameter (inches)	Segment	Branch Diameter (inches)	Carnegie Bell (feet)	Carnegie Spigot (feet)	Flange (feet)	Mechanical Joint Spigot (feet)	Mechanical Joint Bell (feet)
66	A	66	2.72	3.10	3.71	-	-
		60	2.64	3.10	3.71	-	-
		54	2.76	3.10	3.71	-	-
		48	2.73	3.10	3.71	-	-
		42	2.73	3.11	3.71	-	-
		36	2.76	3.10	3.71	-	-
	B	66	8.72	9.10	8.71	-	-
		60	8.64	9.10	8.71	-	-
		54	8.76	9.10	8.71	-	-
		48	8.73	9.10	8.71	-	-
		42	8.73	9.11	8.71	-	-
		36	8.22	8.60	8.21	-	-
	C	66	9.18	9.56	10.21	-	-
		60	9.10	9.56	10.19	-	-
		54	8.22	8.56	9.18	-	-
		48	8.10	8.42	9.17	8.04	8.83
		42	8.07	8.43	9.15	8.04	8.83
		36	8.09	8.33	9.14	8.04	8.83
72	A	72	3.21	3.60	4.22	-	-
		66	3.21	3.60	4.22	-	-
		60	3.13	3.60	4.22	-	-
		54	2.25	2.60	3.22	-	-
		48	2.22	2.60	3.22	-	-
		42	2.22	2.61	3.22	-	-
	B	72	9.21	9.60	10.22	-	-
		66	9.21	9.60	10.22	-	-
		60	9.13	9.60	10.22	-	-
		54	9.25	9.60	10.22	-	-
		48	9.22	9.60	10.22	-	-
		42	9.22	9.61	10.22	-	-
	C	72	9.17	9.56	10.22	-	-
		66	9.17	9.56	10.21	-	-
		60	9.09	9.56	10.19	-	-
		54	8.11	8.56	9.18	-	-
		48	8.10	8.42	9.17	10.00	8.83
		42	8.07	8.43	9.14	10.00	8.83



SECTION 9

REDUCERS

In the application of either concentric or eccentric reducers, consideration needs to be given to the potential thrust developed toward the small end of the reducer, particularly when the piece is made as a reducing adapter involving a plain end or unrestrained joint of any kind.

Thrust restraint is usually not needed if grouted bell and spigot joints are used leading away from the small end. See Section 13 for more details on restraining reducers.

The following pages include laying length formulas for the most frequently used types of concentric reducers. Many other sizes and types can also be fabricated when detailed information is submitted to Thompson Pipe Group. Special reducers that are eccentric, or have different laying lengths than those shown, can also be furnished upon request.

TYPICAL CONCENTRIC REDUCER

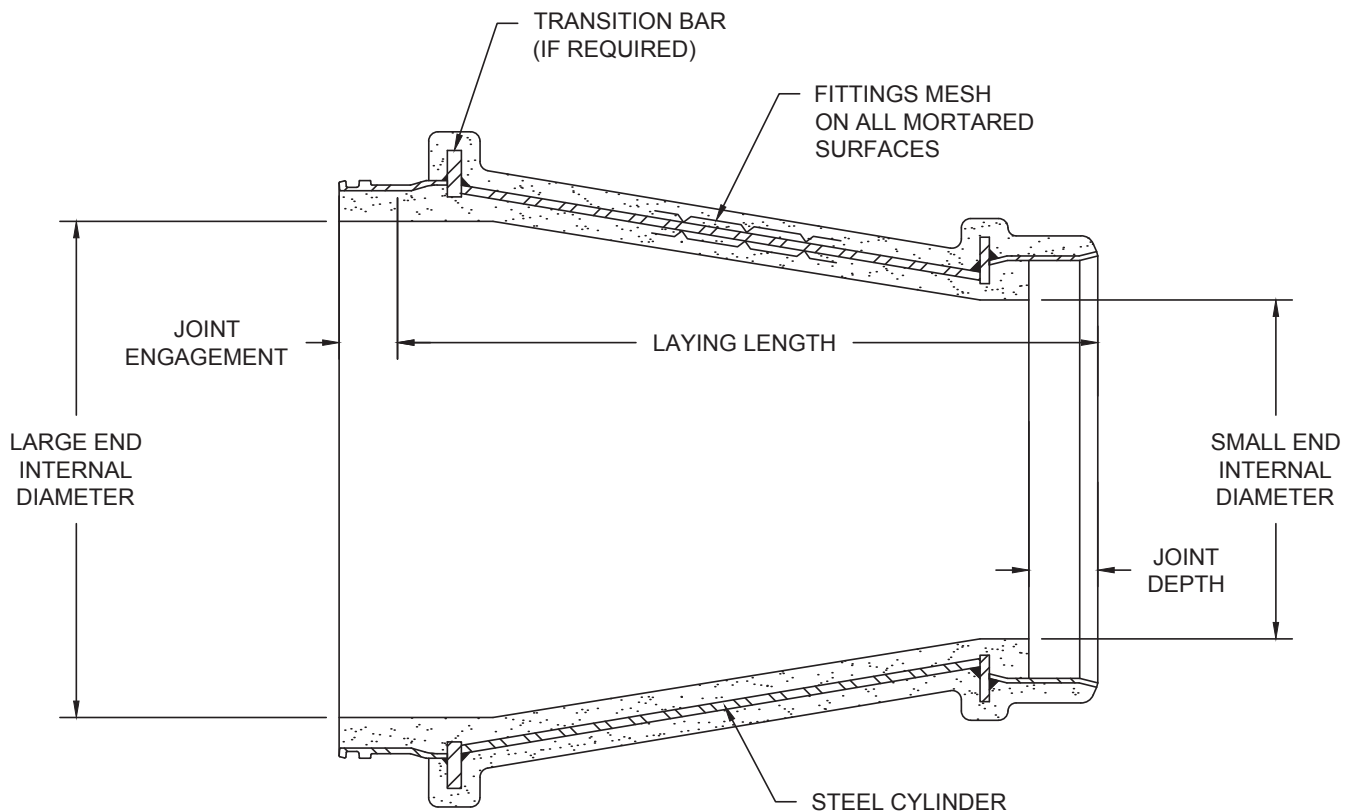

REDUCER LAYING LENGTHS

Nominal laying lengths for concentric or eccentric reducers can be determined by taking the large end diameter minus small end diameter and multiply by four before adding length of joints on both ends. Lay lengths of different joint are listed in table below.

Reducer laying length = (large end diameter – small end diameter) x 4 + joint length

REDUCER JOINT LENGTHS

Bell (feet)	Spigot (feet)	Flange (feet)	MJ Bell (feet)	Plain End (feet)
0.25	0.75	1.00	0.75	2.00

REDUCER CYLINDER THICKNESS

Large End Diameter (inches)	Working Pressure (pounds per square inch)			
	50	100	150	200
	Cylinder Thickness (inches)			
16	3/16	3/16	3/16	3/16
18	3/16	3/16	3/16	3/16
20	3/16	3/16	3/16	3/16
24	3/16	3/16	3/16	1/4
30	3/16	3/16	3/16	5/16
36	3/16	3/16	1/4	3/8
42	1/4	1/4	1/4	3/8
48	1/4	1/4	5/16	7/16
54	5/16	5/16	3/8	1/2
60	5/16	5/16	3/8	1/2
66	3/8	3/8	7/16	9/16
72	3/8	3/8	1/2	5/8
78	7/16	7/16	1/2	3/4
84	7/16	7/16	9/16	3/4
90	1/2	1/2	9/16	3/4
96	1/2	1/2	5/8	7/8



ADAPTERS

Adapters are used primarily to connect concrete pressure pipe to valves or pipelines made of other materials. Thompson Pipe Group can manufacture adapters to fit various non-proprietary types of joints. The ends are fabricated or machined to the dimensions required to connect to the adjoining piece.

SPIGOT x FLANGE ADAPTER

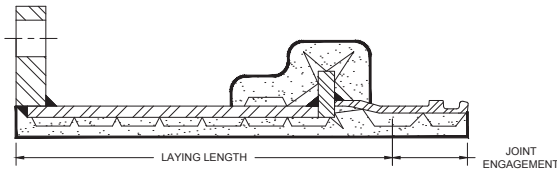

SPIGOT x SPIGOT JOINT ADAPTER

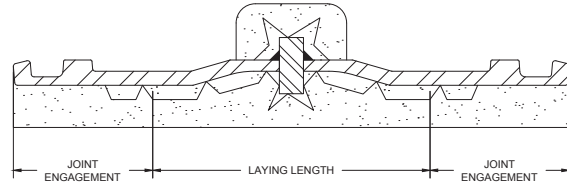

BELL x FLANGE ADAPTER

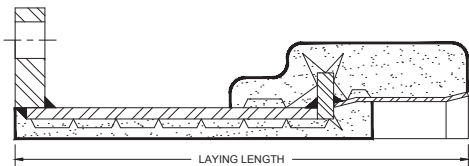

BELL x BELL JOINT ADAPTER

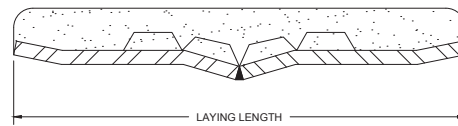

Pipe Diameter (inches)	Flange by	
	Spigot (feet)	Bell (feet)
16	1.47	1.09
18	1.47	1.09
20	1.55	1.18
24	1.56	1.19
30	1.57	1.20
36	1.59	1.22
42	1.60	1.23
48	1.63	1.25
54	1.98	1.53
60	2.00	1.54
66	2.04	1.66
72	2.05	1.66
78	2.06	1.66
84	2.06	1.65
90	2.10	1.68
96	2.10	1.68

Pipe Diameter (inches)	Double Spigot (feet)	Double Bell (feet)
18	1.03	0.02
20	1.03	0.02
24	1.03	0.02
30	1.03	0.02
36	1.03	0.02
42	1.03	0.02
48	1.03	0.02
54	1.24	0.34
60	1.25	0.33
66	1.27	0.50
72	1.27	0.48
78	1.27	0.46
84	1.27	0.44
90	1.29	0.44
96	1.29	0.44

Mechanical joint bell and spigot adapters

MECHANICAL JOINT SPIGOT X SPIGOT

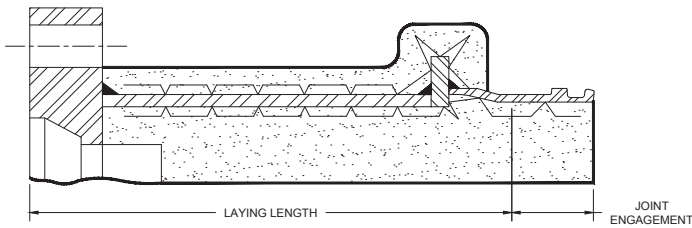

MECHANICAL JOINT SPIGOT X SPIGOT

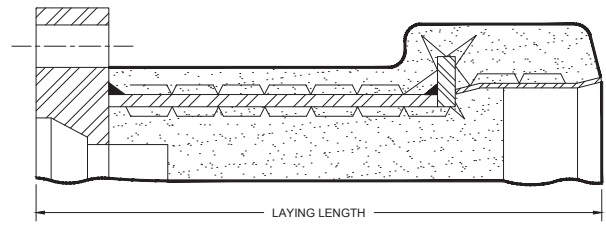

MECHANICAL JOINT SPIGOT X SPIGOT

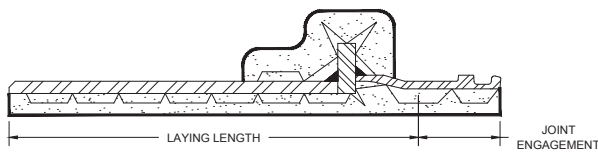

MECHANICAL JOINT SPIGOT X BELL

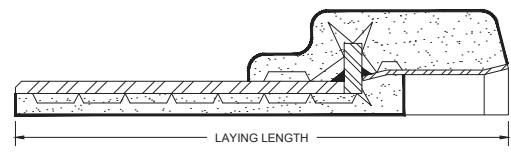

ANCHORED MECHANICAL JOINT SPIGOT X SPIGOT

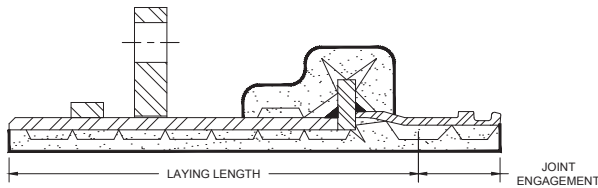

ANCHORED MECHANICAL JOINT BELL X BELL

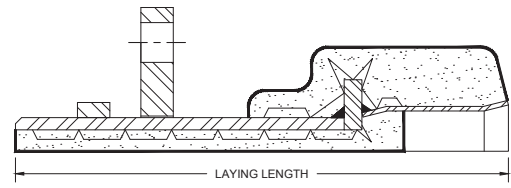

Pipe Diameter (inches)	Mechanical Joint Bell by		Mechanical Joint Spigot by		Anchored Mechanical Joint Spigot by	
	Spigot (feet)	Bell (feet)	Spigot (feet)	Bell (feet)	Spigot (feet)	Bell (feet)
16	1.11	0.78	2.54	2.27	1.63	1.25
18	1.11	0.78	2.54	2.27	1.63	1.25
20	1.13	0.79	2.54	2.27	1.63	1.25
24	1.13	0.79	2.54	2.27	1.63	1.25
30	1.10	0.73	2.56	2.29	1.65	1.27
36	1.13	0.75	2.56	2.28	1.65	1.27
42	1.20	0.82	2.60	2.29	1.85	1.48
48	1.20	0.82	2.60	2.28	1.85	1.48

Adapters are also used to reverse the laying direction (Bell x Bell adapters), to install closures (Spigot x Spigot adapters), or to make minor grade or alignment changes beyond normal joint deflection when unmarked utilities or other obstacles are encountered (bevel adapters).

VICTAULIC ADAPTERS

VICTAULIC X SPIGOT

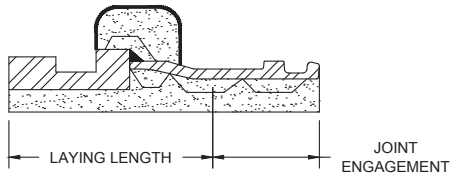

VICTAULIC X BELL

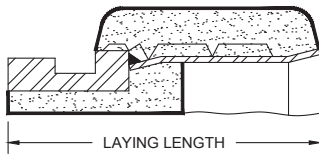

Pipe Diameter (inches)	Victaulic by	
	Spigot (feet)	Bell (feet)
16	0.83	0.46
18	0.83	0.46
20	0.83	0.46
24	0.83	0.46
30	0.88	0.50
36	0.83	0.46
42	0.83	0.46
48	0.83	0.46
54	1.02	0.57
60	1.02	0.56

JOINT HARNESS ADAPTERS

SPIGOT x SPIGOT JOINT ADAPTER

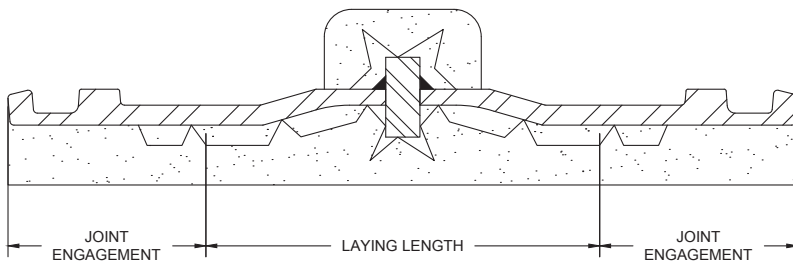

BELL x BELL JOINT ADAPTER

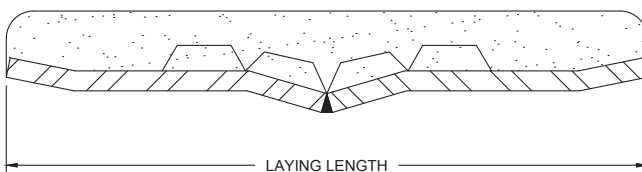

BEVEL ADAPTERS

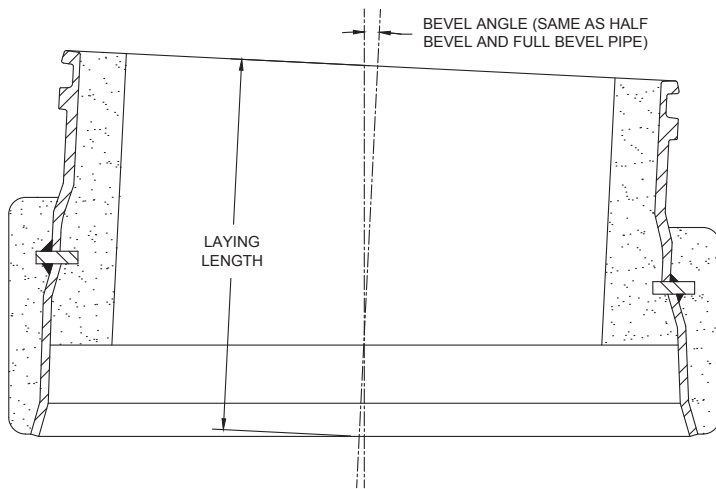

Pipe Diameter (inches)	Half Bevel			Full Bevel	
	Maximum Joint Opening** (inches)	Range of Deflection Angle (degrees)	Average Laying Length* (feet)	Range of Deflection Angle (degrees)	Average Laying Length* (feet)
16 LCP	1-3/4	-	-	0.00 - 9.53	0.68
18 LCP	1-3/4	-	-	0.00 - 8.96	0.69
20 LCP	1-3/4	0.00 - 6.43	0.66	0.00 - 8.50	0.70
24 LCP	1-3/4	0.00 - 5.72	0.67	0.52 - 7.80	0.71
30 LCP	1-3/4	0.00 - 5.02	0.68	1.25 - 7.10	0.73
36 LCP	1-3/4	0.00 - 4.54	0.69	1.74 - 6.63	0.75
42 LCP	1-3/4	0.00 - 4.24	0.77	2.12 - 6.36	0.84
48 LCP	1-3/4	0.26 - 3.98	0.78	2.38 - 6.09	0.86
36 ECP	1-3/4	0.00 - 4.77	0.69	1.83 - 6.97	0.75
42 ECP	1-3/4	0.00 - 4.45	0.77	2.22 - 6.67	0.84
48 ECP	1-3/4	0.28 - 4.19	0.78	2.51 - 6.42	0.86
54ECP	7/8	1.36 - 3.10	0.97	3.59 - 5.32	1.06
60 ECP	1	1.34 - 3.14	0.98	3.58 - 5.37	1.08
66 ECP	1-1/8	1.33 - 3.16	1.08	3.57 - 5.40	1.20
72 ECP	1-1/4	1.31 - 3.19	1.08	3.55 - 5.43	1.21
78 ECP	1-3/8	1.30 - 3.21	1.08	3.55 - 5.46	1.22
84 ECP	1-1/2	1.29 - 3.23	1.08	3.54 - 5.48	1.23
90 ECP	1-5/8	1.28 - 3.24	1.10	3.54 - 5.50	1.26
96 ECP	1-5/8	1.34 - 3.19	1.11	3.60 - 5.44	1.28

*Bevel adapters with restrained joints (harnessed or Snap Ring®) are also available with slightly different laying lengths. Restrained joint bevel adapters permit less joint opening than listed above, limiting their angular deflection to a tighter range than the standard bevel adapter. Bevel adapters for pipe larger than 96 inches are uncommon, but may be supplied.

**Bevel adapters for 48-inch and smaller pipe are based on using the deep joint. Bevel adapters for 54-inch and larger pipe are based on the use of the standard joint.



MISCELLANEOUS FITTINGS

A certain number of miscellaneous fittings are relatively commonplace on most projects. Typical applications shown in this section include bulkheads, night caps, wall pieces, and closures. Other types of special fittings can be custom made where their use justifies the cost and where manufacturing capabilities permit their fabrication.

BULKHEADS AND NIGHT CAPS

The most common bulkhead designs are the dished and flat plate type, which can be supplied for either temporary or permanent installation. When mechanically restrained bulkheads are used, a sufficient distance of the adjoining pipe must also be restrained. It is important that flat plate bulkheads be braced or thrust blocked to perform correctly.

Night caps or night plugs are temporary and can be provided for construction convenience to prevent debris from entering the pipeline during construction. They are not intended for permanent installation or testing under any conditions or circumstances.

BULKHEAD CAP/PLUG

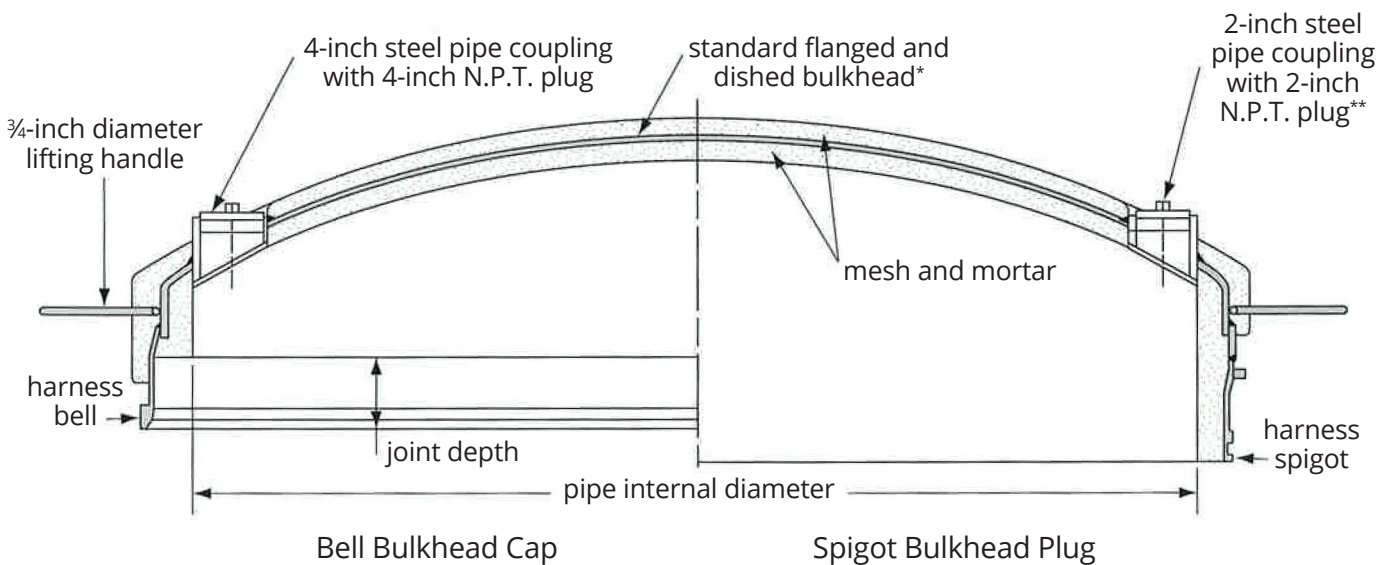

*Ellipsoidal and other types can be provided on request.

**Other outlet sizes and types available upon request.

NIGHT CAP/PLUG

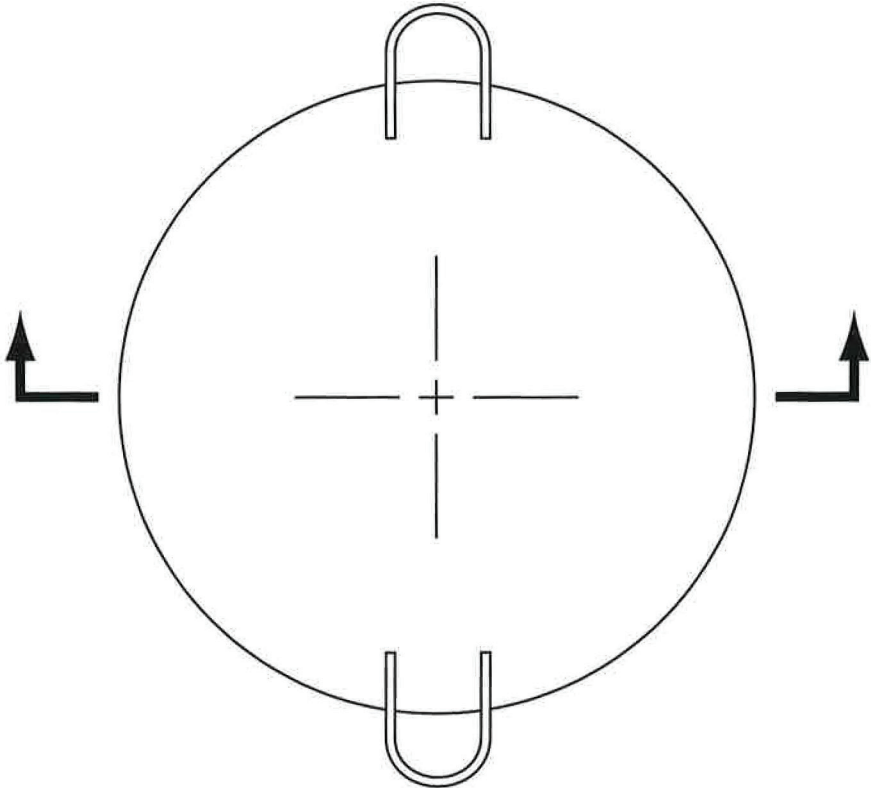
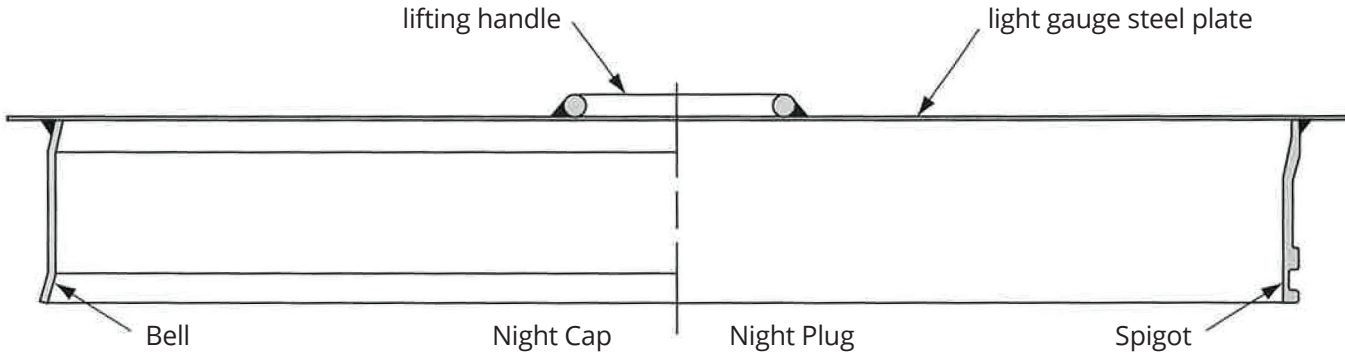

EXTERNALLY BRACED BULKHEAD

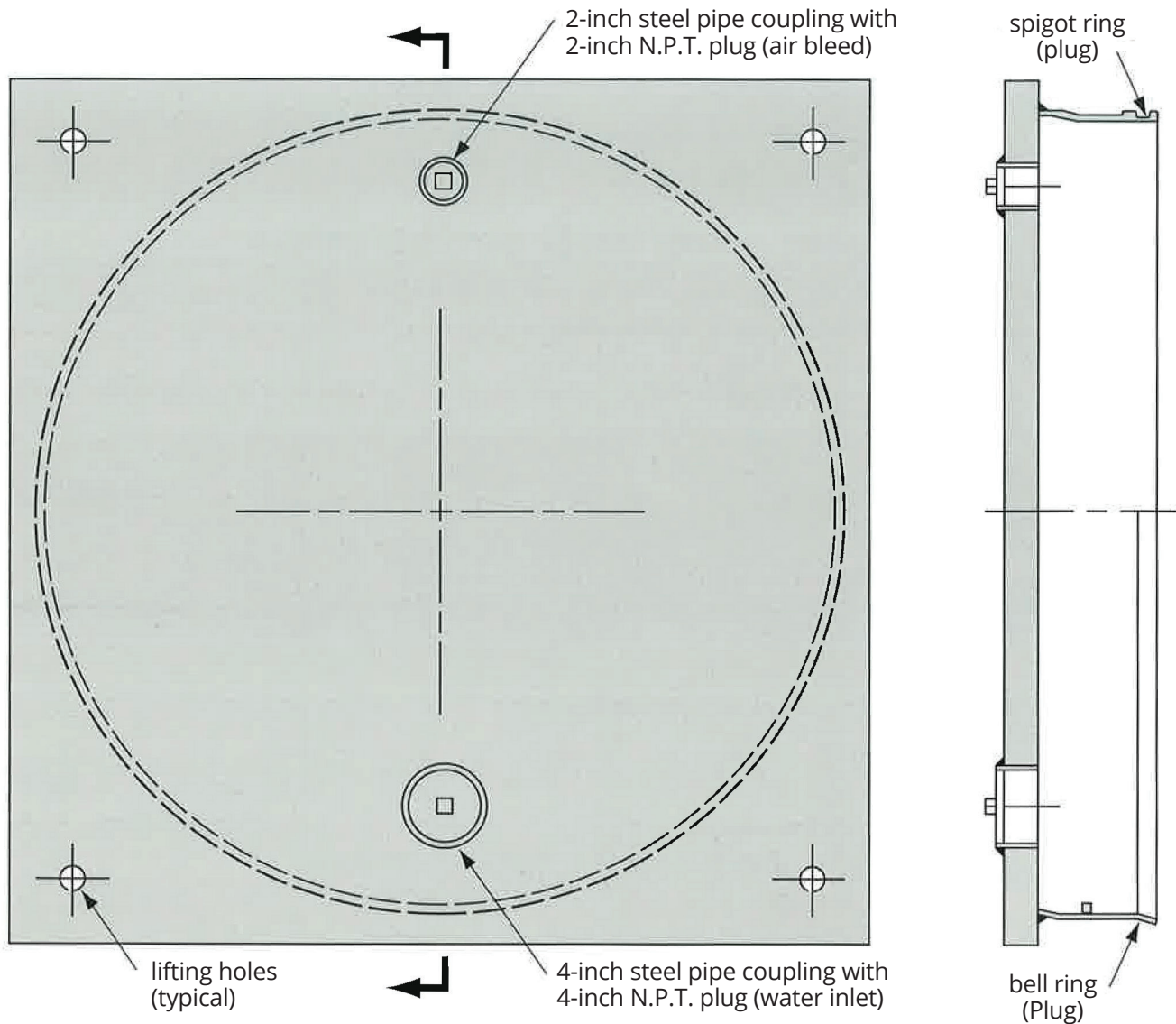

Note: This type of bulkhead must be externally braced.

WALL PIECES

A bell or spigot wall piece fits into the wall of a structure and connects to a regular pipe joint on the outside face. When pouring concrete around a wall piece, it is critical to either brace the wall piece before pouring the wall in order to maintain its roundness, or join the wall piece with a pipe section before the wall is poured and leave it joined until the concrete has cured. This will assure that the joint ring in the wall piece will maintain its roundness. Wall pieces with mechanically restrained joints are available for restrained joint applications.

SPIGOT WALL PIECE – FULL WALL PENETRATION

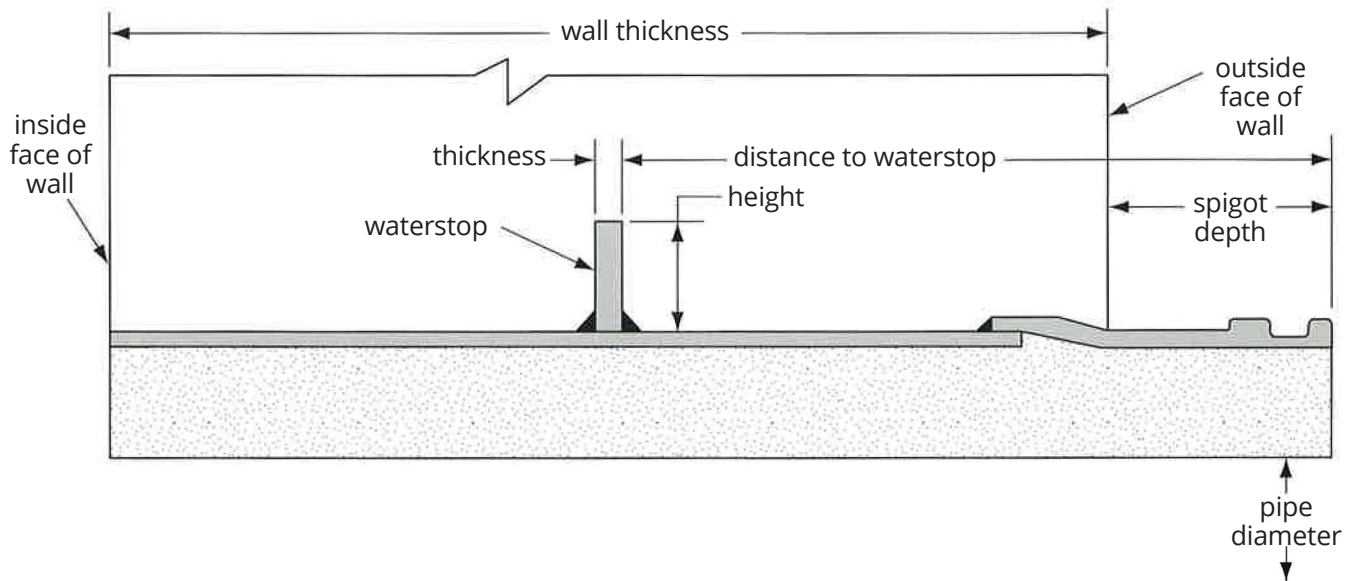

BELL WALL PIECE – FULL WALL PENETRATION

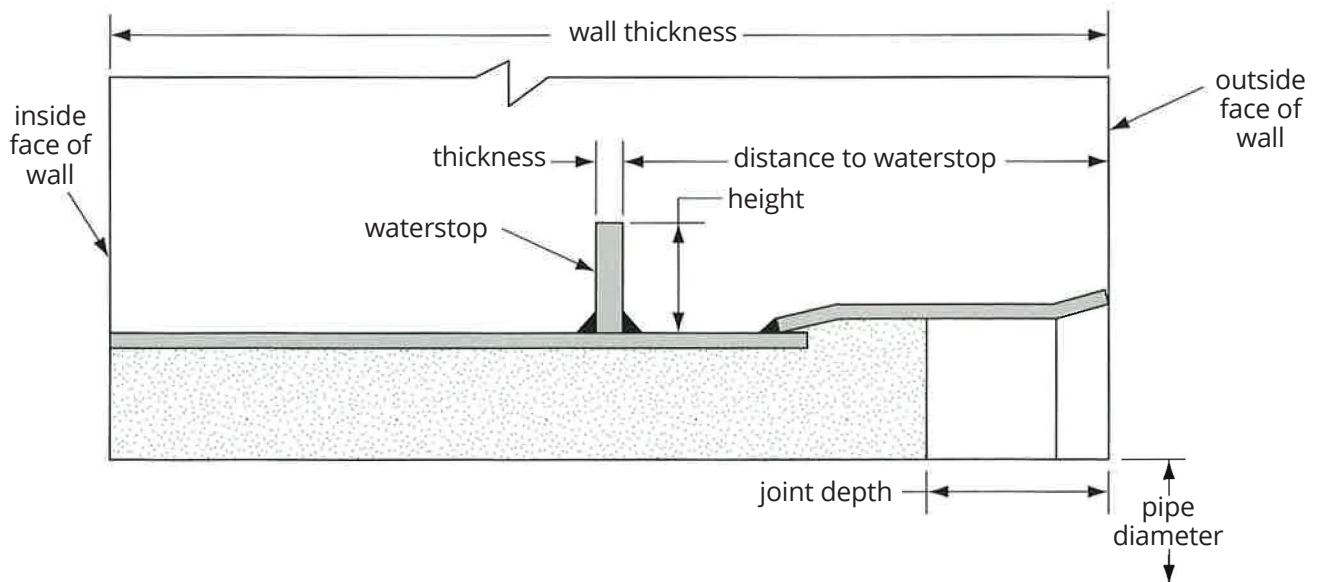

SPIGOT WALL PIECE - PARTIAL WALL PENETRATION

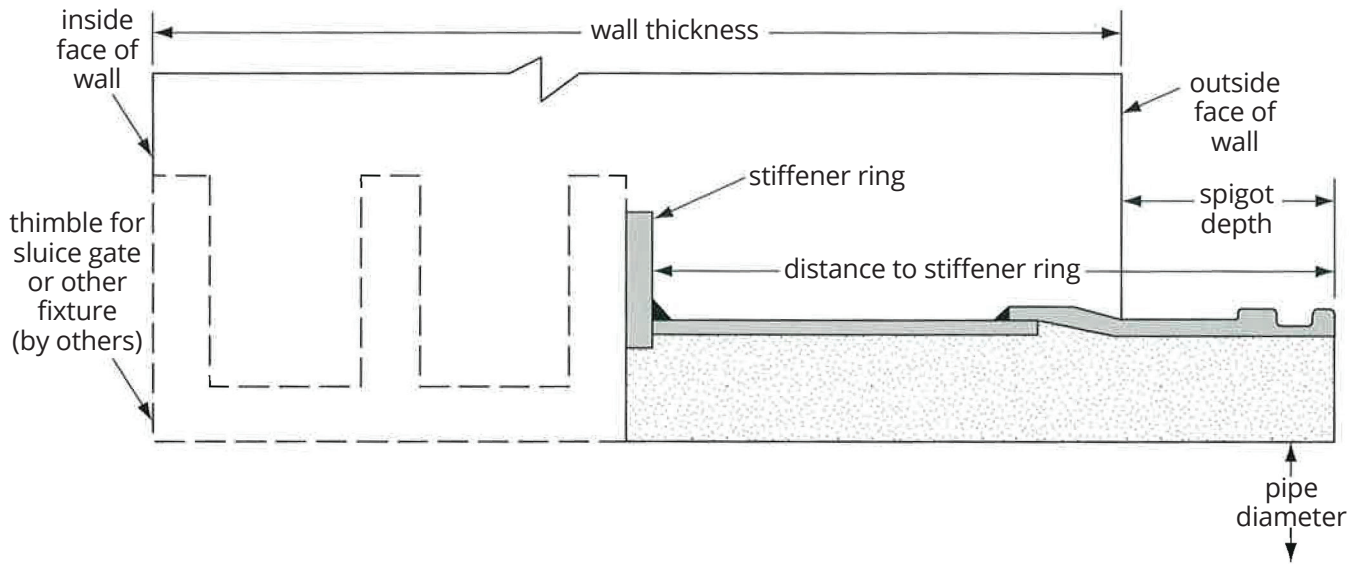

BELL WALL PIECE - PARTIAL WALL PENETRATION

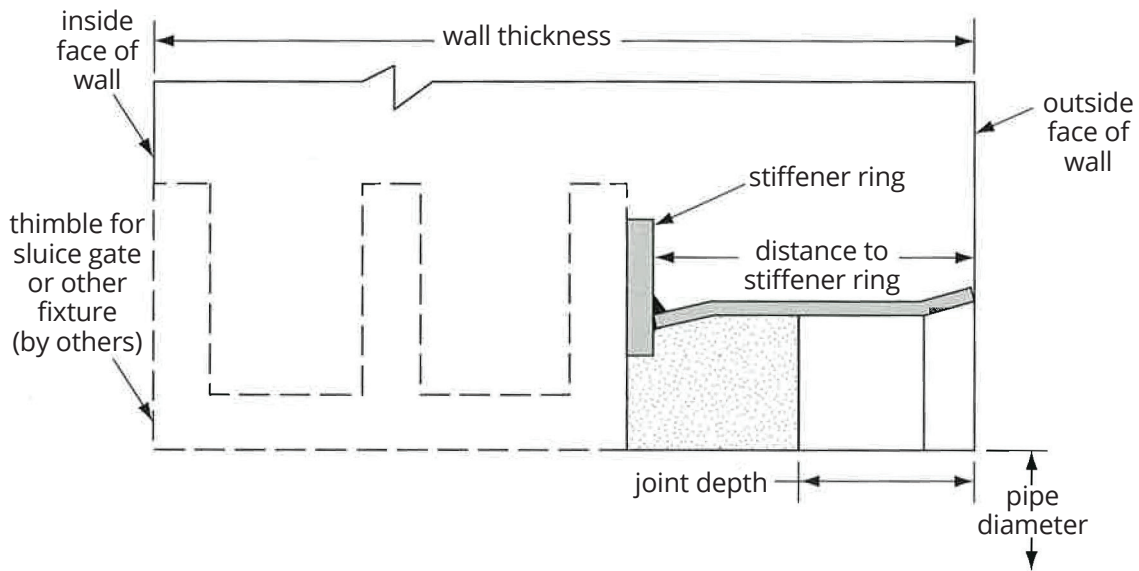

WALL PIECES - JOINTS AT BOTH FACES

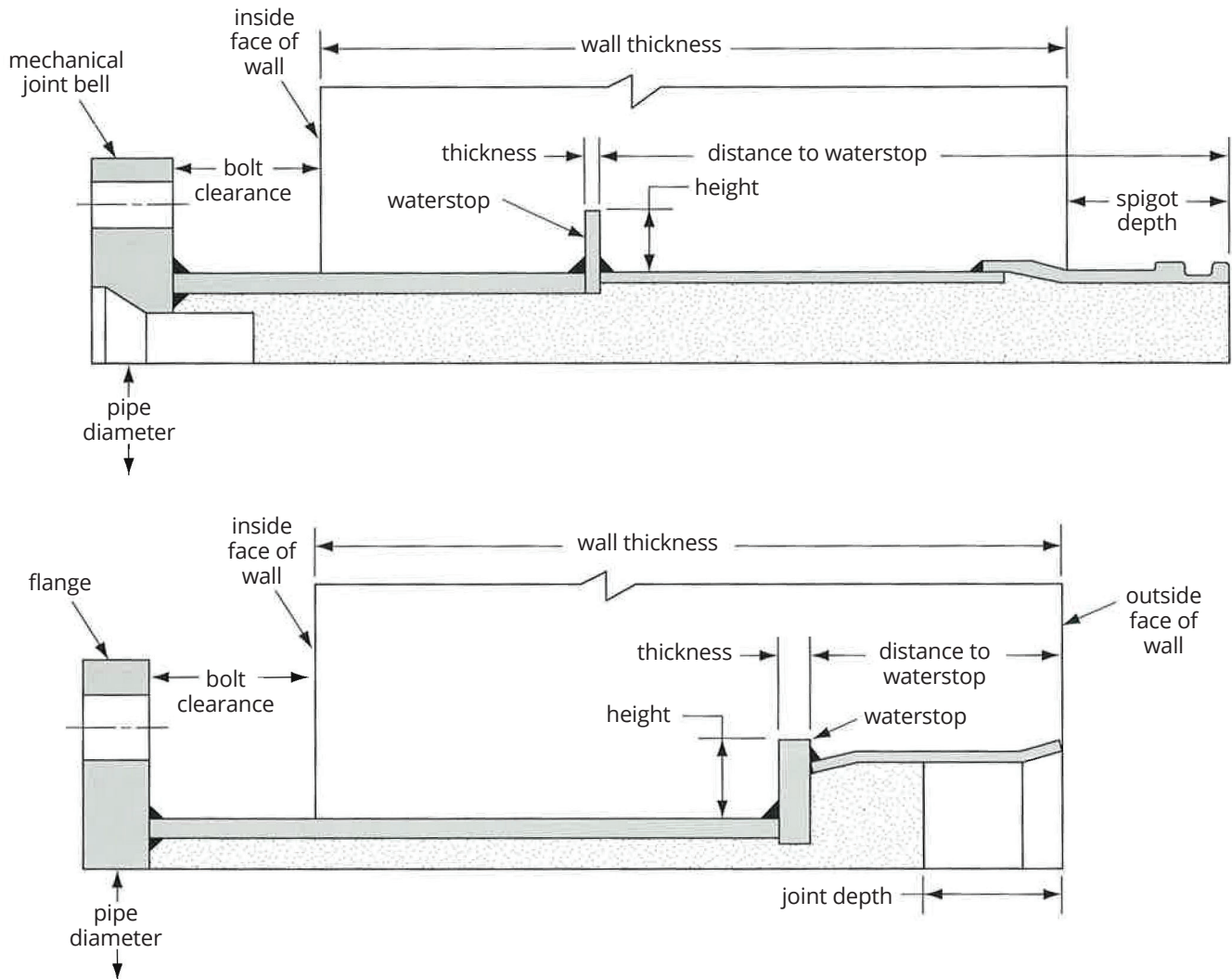

- Notes :
1. Special wall pieces can be supplied with restrained joint bells and spigots. These joint rings must protrude beyond the face of the structure to permit proper assembly of the joint.
 2. Flange and mechanical joint bell ends can be supplied with tapped (threaded) bolt holes such that the face of the flange or mechanical joint bell ends can be cast flush with the inside face of the structure.
 3. Wall pieces with ends other than those shown here can be supplied.
 4. When wall pieces with restrained joint ends and water stops or anchor rings are specified, thrust will be transmitted into the wall of the structure. Design of the structure for such thrust is not Thompson Pipe Group's responsibility.

WALL PIECES – DIMENSIONS

Pipe Diameter (inches)	Distance to Waterstop		Spigot Depth (inches)	Joint Depth (inches)	Waterstop	
	Bell (inches)	Spigot (inches)			Thickness (inches)	Height (inches)
16	6	6	5	4-1/2	1/2	2
18	6	6	5	4-1/2	1/2	2
20	6	6	5	4-1/2	1/2	2
24	6	6	5	4-1/2	1/2	2
30	6	6	5	4-1/2	1/2	2
36	6	6	5	4-1/2	1/2	2
42	6	6	5	4-1/2	1/2	3
48	6	6	5	4-1/2	1/2	3
54	6	7-1/4	4-3/4	4-1/8	1/2	3
60	6	7-1/4	4-7/8	4-1/4	1/2	4
66	7	7-1/4	5	4-3/8	1/2	4
72	7	7-1/4	5-1/8	4-1/2	1/2	4
78	7	7-1/4	5-1/4	4-5/8	1/2	4
84	7	7-1/4	5-1/2	4-3/4	1/2	4
90	7	7-1/4	5-5/8	4-7/8	1/2	4
96	7	7-1/4	5-3/4	5	1/2	4

- Notes :
1. Normally the waterstop is located at mid-wall of the structure. Distances listed are the minimum distances possible with standard joints.
 2. Dimensions given are for deep joints in diameters 16- to 48-inch and standard joints in diameters 54- to 96-inch.
 3. Wall pieces with other end connections are available.

CLOSURES

Follower ring or field welded closures are used on most pipeline projects to close lines laid from two directions. They can be field cut to suit the gap in the line. Standard length for closures is 6 feet. Closures may be field cut to as little as 2 feet. For gaps larger than 6 feet, a short pipe and closure are used.

Since a closure has two bell ends, the adjacent pipe sections must have spigot ends. If necessary, a double spigot adapter (see Section Ten) can be used to convert a bell end on a pipe section to a spigot end. The two pipe sections to be joined must be in proper alignment to accept the closure.

For a closure to be made, the spigot ends must not be more than 1 inch out of line or grade. Closures with restrained joints are also available when the closure is made in a restrained joint area. However, whenever possible, closures should be located in areas which do not require restrained joints. When the closure has been installed, it is very important that the closure installation be pressure tested. During this test period, the follower rings should be temporarily blocked.

Following this test, the closure must be completely encased in a concrete collar to provide protection against corrosion.

In addition to the closures shown here, which have bell and spigot joints, we can also supply closures with other types of joints such as a mechanical coupling end or a plain end for field welding.

FOLLOWER RING CLOSURE INSTALLATION

OPEN POSITION

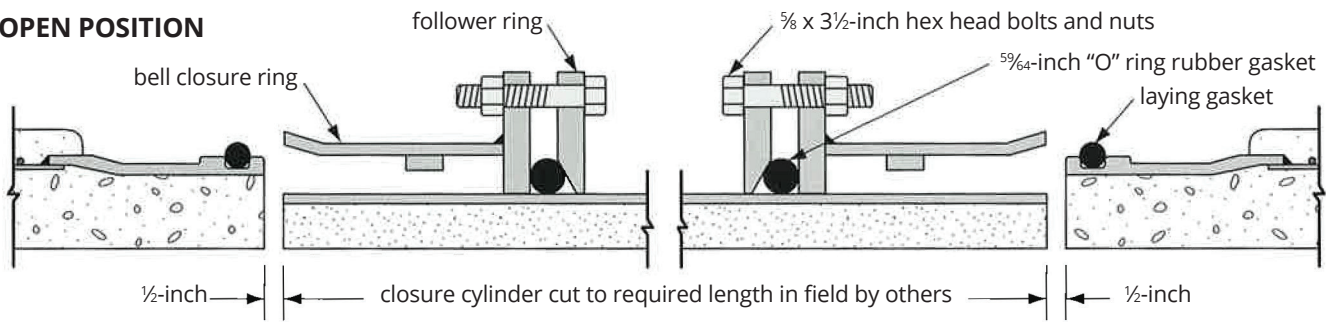

CLOSED POSITION

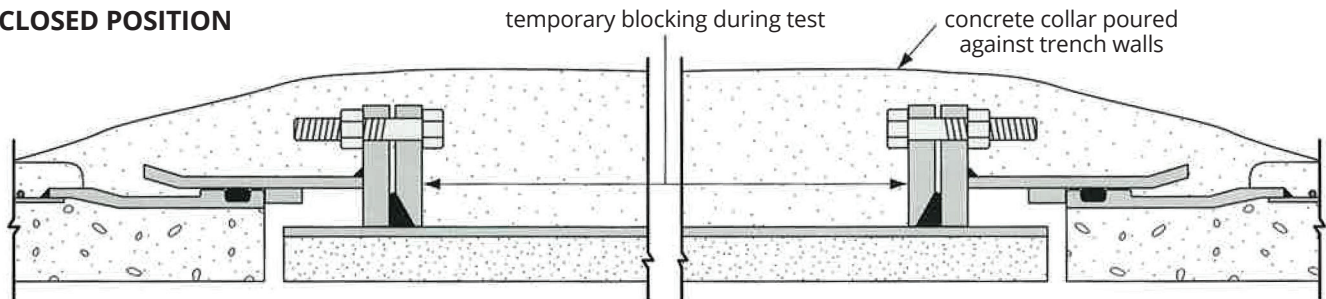

- Notes :
1. Weld thickness "T" as specified on laying schedule.
 2. Closure installation must be pressure tested before concrete collar is cast.
 3. Closure cylinder thickness must be equal to or greater than fitting plate thickness listed on design sheet.
 4. Double spigot adapter not included unless ordered.

THE SPLIT BUTT-STRAP CLOSURE SECTION

The split butt-strap closure section has a factory attached joint/plain end assembly. This plain end is adjacent to the field-adjusted plain end when the closure is positioned in the final gap in the pipeline. A split butt-strap is welded over the two plain ends and the line is closed out.

- A. Short piece with access
- B. Split butt-strap (two pieces)
- C. Short piece
- D. Access detail "D" - 10" - 18"; 1 req'd., 20" & 24"; 2 required.
- E. Access detail "E": 27" - 144"; 1 required.

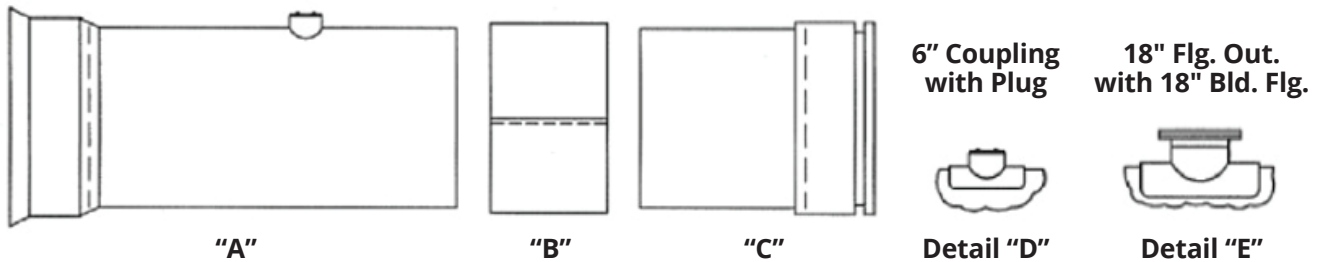

INSTALLATION PROCEDURE

1. Measure clear space distance between joints of existing pipe.
2. Cut piece "C" to the required length.
3. Place piece "A" & "C" in the line; make up the joints in the normal manner.
4. Weld split butt-strap (piece "B") in place.
5. Make up inside pipe and closure gap with cement mortar (1" minimum)

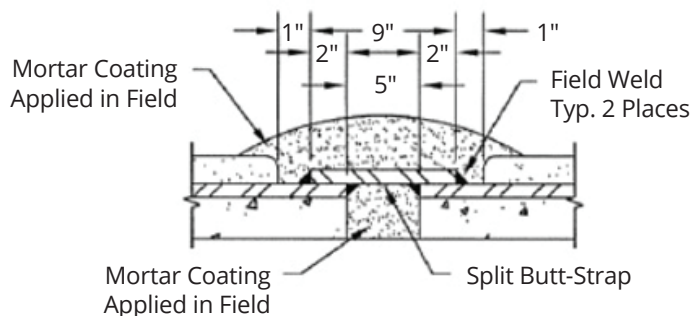
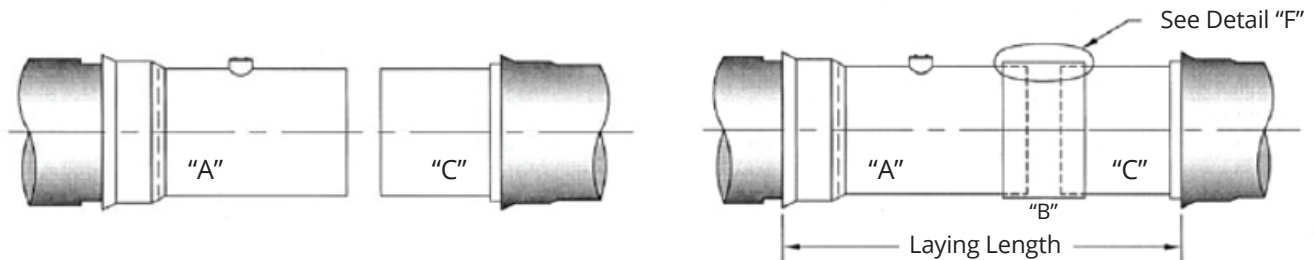

Detail "F"

CUSTOM FITTINGS

Custom fittings can be made to your dimensions which can, in many cases, be more economical than an assembly of two or more standard fittings. These specially designed and built fittings will result in major savings in installation time as well as provide a smooth transition in pipe size or direction.

Thompson Pipe Group can provide many unique and complex fittings to meet pipeline requirements.

Special manifolds, wyes, crosses, and offsets are among the more frequently required types of special fittings. Fittings up to 192 inches in diameter have been specially fabricated by Thompson Pipe Group.

CUSTOM FITTING EXAMPLES

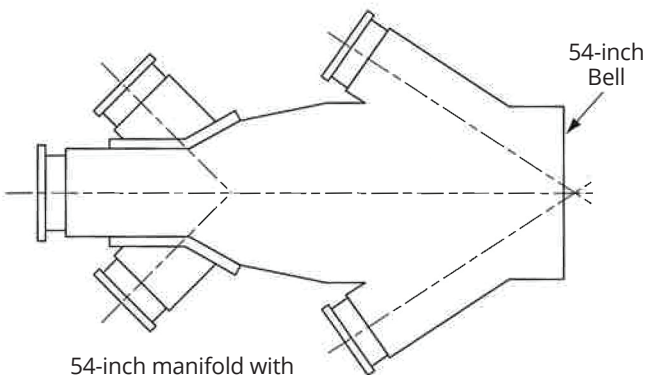

54-inch manifold with five 20-inch flange branches

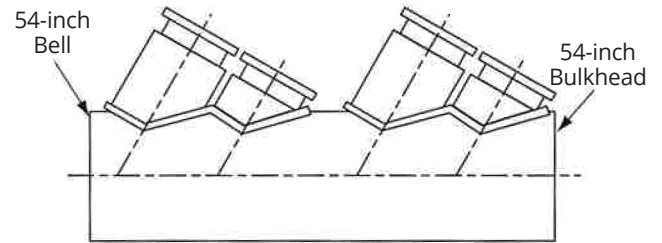

54-inch manifold with four 30-inch flange outlets

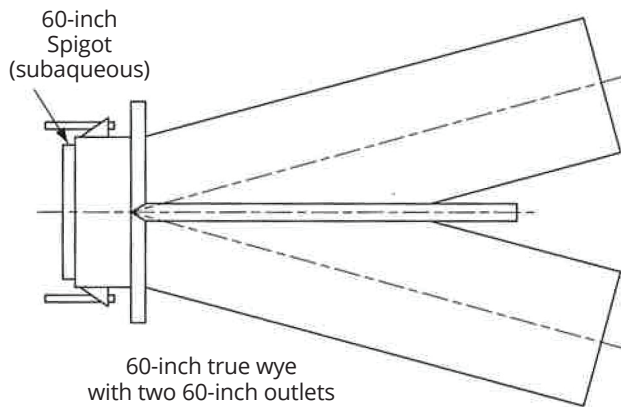

60-inch true wye with two 60-inch outlets

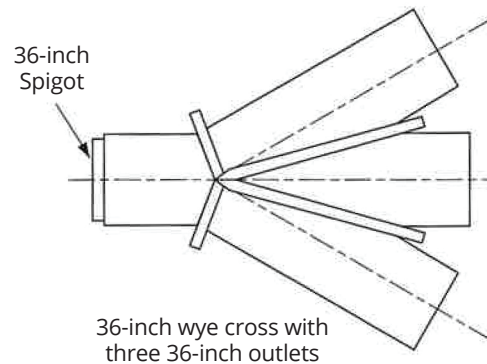

36-inch wye cross with three 36-inch outlets



PCCP AND BWP DESIGN

Thompson Pipe Group manufactures prestressed concrete cylinder pipe in compliance with the AWWA C301 standard and bar-wrapped concrete cylinder pipe in compliance with the AWWA C303 standard. Prestressed pipe design is in accordance with the AWWA C304 Standard. The design of bar-wrapped pipe is done in accordance with the AWWA M9 Manual for Concrete Pressure Pipe. These standards and manual are the result of the continuing research and technology development efforts of the American Concrete Pressure Pipe Association (ACPPA) and the American Water Works Association (AWWA).

The AWWA C304 standard for the design of Prestressed Concrete Cylinder Pipe (PCCP) was first issued in 1992. It was the culmination of a considerable amount of research and analysis work done by AWWA, ACPPA, and engineers. The procedure is based on a review of past, industry-conducted three-edge bearing tests, hydrostatic pressure tests, and specially conducted combined load tests, along with a finite element analysis. Once completed, the standard was vetted in accordance with AWWA procedures. This standard covers the design procedure for both types of PCCP; Lined Cylinder Pipe and Embedded Cylinder Pipe.

Unlike flexible pipes, PCCP is designed for the simultaneous application of internal pressure and external load. The pipe is a rigid structure thus, it does not rely upon soil side support to enable it to handle external loads. As a result, bedding and backfilling PCCP will be faster and more economical.

To complement the AWWA C304 standard, a computer program was developed to perform the necessary design calculations. The pipe designer will look to the consulting engineer for the following design parameters:

- Internal working pressure – the long-term, steady state pressure for the system
- Internal transient pressure – the pressure that can be expected during a surge or water hammer event; expressed as a pressure over and above the working pressure (the AWWA C304 standard requires the pipe designer to use a pressure of 40% of the working pressure or 40 psi, whichever is greater if the transient pressure is not specified)
- Field test pressure – the post-construction pressure used to test the pipeline for leaks and any structural issues (the AWWA M9 Manual for Concrete Pressure Pipe recommends a field test pressure not to exceed 1.2 times the working pressure)
- External dead load – the load resulting from the earth cover over the top of the pipe; this is generally based on the project's profile drawings
- External live load – very short term external loads such as traffic, construction equipment, and railroad trains (the PCCP industry will always use an AASHTO HS20 truck live load, or loads as specified, in the pipe design calculations)

Trench Width

The bedding under the pipe has a great influence on its ability to handle external loads. The AWWA C304 standard and the AWWA M9 Manual contain illustrations of five different bedding details recommended for PCCP. The bedding types are designated R1, R2, R3, R4, and R5. Type R3 bedding is the most commonly used and provides suitable bedding for a wide range of applications. The suggested bedding types for PCCP are shown in Figure 12-1 (taken from the AWWA M9 Manual for Concrete Pressure Pipe).

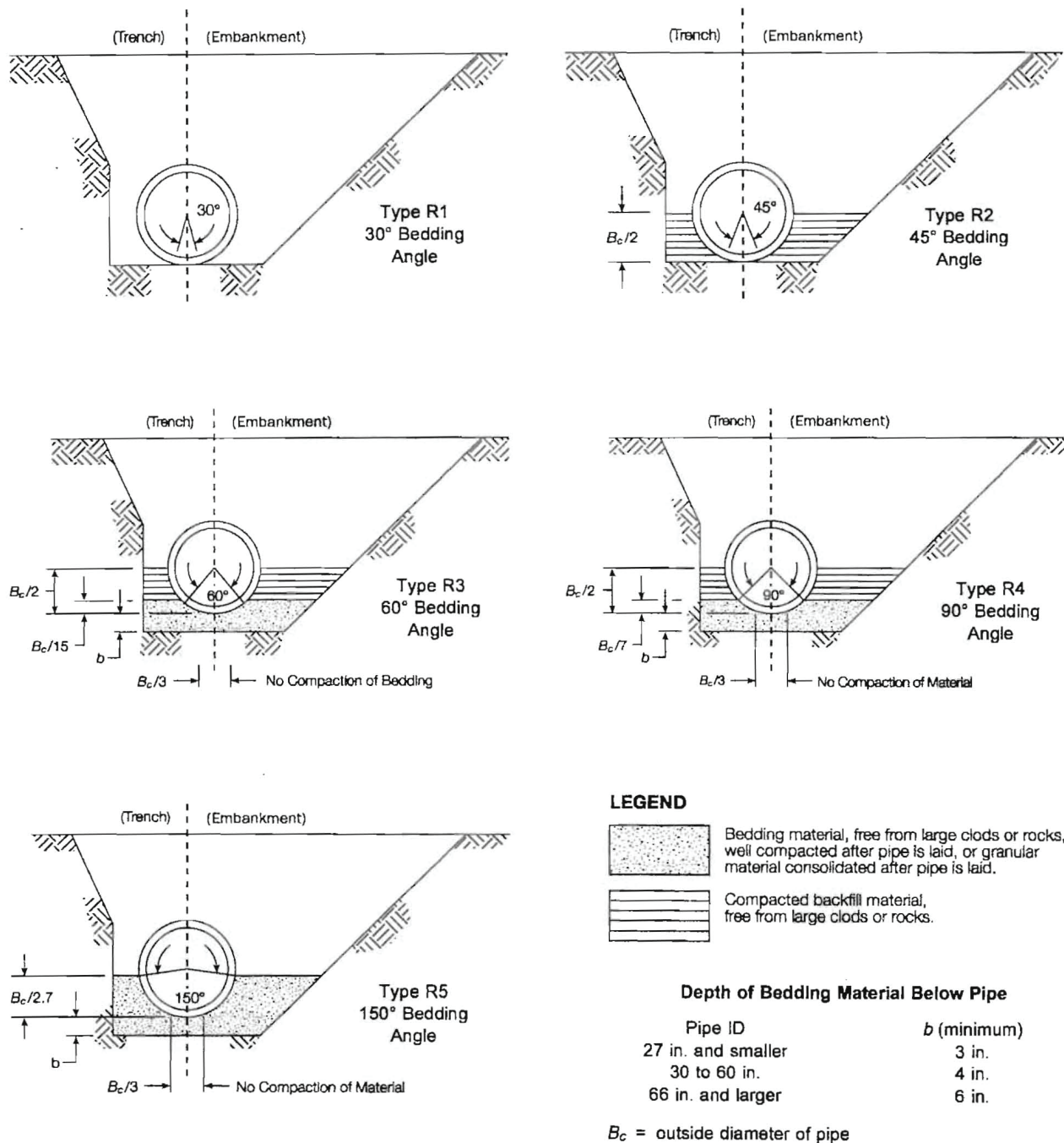

- NOTES:
1. Embankment condition indicates the trench width at the top of the pipe exceeds transition width.
 2. For bedding types R1 and R2, the trench bottom shall be overexcavated and bedding material shall extend to depth b below the bottom of pipe if subgrade is rock or other unyielding material.

Figure 12-1

The goal of the pipe designer is to determine the amount of circumferential prestressing needed to handle the expected internal pressures and external loads. The center-to-center spacing of the prestressing wires will provide the necessary compression in the structural concrete core. Wires more closely spaced will provide a stronger pipe and vice versa. This provides another benefit to using PCCP. Designs are customized for each project thus, there is no expensive over-design as can occur with other types of pipe.

An example of the AWWA C304 design program output is shown in Figure 12-2.

Company: Thompson Pipe Group
 Project: 42-in LCP WTM UDP Version 1.8
 Designer: John Doe AWWA C304-99
 File Name: 42-IN LCP WTM 08-22-2019

DESIGN SUMMARY

GEOMETRY

Type = LCP(Core Spun) Di = 42.00 in. Dy = 47.25 in. (OD)
 hc = 2.625 in. hm = 0.942 in. ty = 0.0598 in.
 ds = 0.192 in. As = 0.266 in²/ft Pipe OD = 49.13 in.

MATERIAL PROPERTIES

f'c = 6,000 psi f't = 542 psi f'ci = 4,000 psi
 f'm = 5,500 psi f'tm = 519 psi fyy = 33,000 psi
 ASTM A648 Wire Class III fsg = 189,000 psi fsu = 252,000 psi
 n = 7.102 n' = 7.609 Cphi = 1.00
 Cs = 1.00 CE = 1.00 CR = 1.00

EXPOSURE

RH = 70 % t1 = 270 days t2 = 90 days

BEDDING: 60 deg. Olander

	Earth	Thrust Pipe	Fluid	Earth	Moment Pipe	Fluid
Side	0.5759	0.3026	-0.0595	0.0858	0.1016	0.0955
Invert	0.3447	0.1029	-0.3100	0.1454	0.2157	0.1550

LOADS: Marston Positive Projection

Pw = 100 psi Pt = 40 psi Pft = 120 psi
 H = 8.000 ft w = 120 lb/ft³
 Kmu = 0.190 rsdp = 0.500
 We = 5,716 lb/ft Wt = 417 lb/ft
 Wp = 538 lb/ft Wf = 600 lb/ft

INITIAL PRESTRESS

fic = 1,310 psi fiy = 10,307 psi fis = -179,368 psi
 ni = 7.355 ni' = 7.869

FINAL PRESTRESS

Po = 125 psi fcr = 935 psi fyr = 16,770 psi
 fsr = -153,325 psi R = 0.105212
 phi = 0.905 s = 0.000097
 nr = 6.987 nr' = 7.502

PIPE CHARACTERISTICS

P'k = 157 psi Pb = 350 psi

Criterion number 1 controls the design.

Figure 12-2

Bar-Wrapped Concrete Pipe (B-303) is designed in accordance with the AWWA M9 Manual for Concrete Pressure Pipe, Chapter 7. B-303 is considered a semi-rigid pipe due to its ability to deflect and develop side support from the backfill soil. As a semi-rigid pipe, it is designed for internal pressures and external loads separately.

The pipe designer will look to the consulting engineer for the following design parameters:

Internal working pressure – the long-term, steady state pressure for the system

Internal transient pressure – the pressure that can be expected during a surge or water hammer event; expressed as a pressure over and above the working pressure (the Thompson Pipe Group designers will use a pressure of 40% of the working pressure or 40 psi, whichever is greater if the transient pressure is not specified)

Field test pressure – the post-construction pressure used to test the pipeline for leaks and any structural issues (the AWWA M9 Manual for Concrete Pressure Pipe recommends a field test pressure not to exceed 1.2 times the working pressure)

TRENCH WIDTH

External dead load – the load resulting from the earth cover over the top of the pipe; this is generally based on the project’s profile drawings

External live load – very short term external loads such as traffic, construction equipment, and railroad trains (the B-303 industry will always use an AASHTO HS20 truck live load in the pipe design calculations)

Modulus of soil reaction – usually known as E' ; this is a measure of the how much support will be available from the backfill on the sides of the pipe (if not specified, Thompson Pipe Group will use an E' of 1000 psi)

The bedding under and backfill around the pipe have an influence on its ability to handle external loads. The recommended bedding and backfill for B-303 pipe is shown in Figure 12-3.

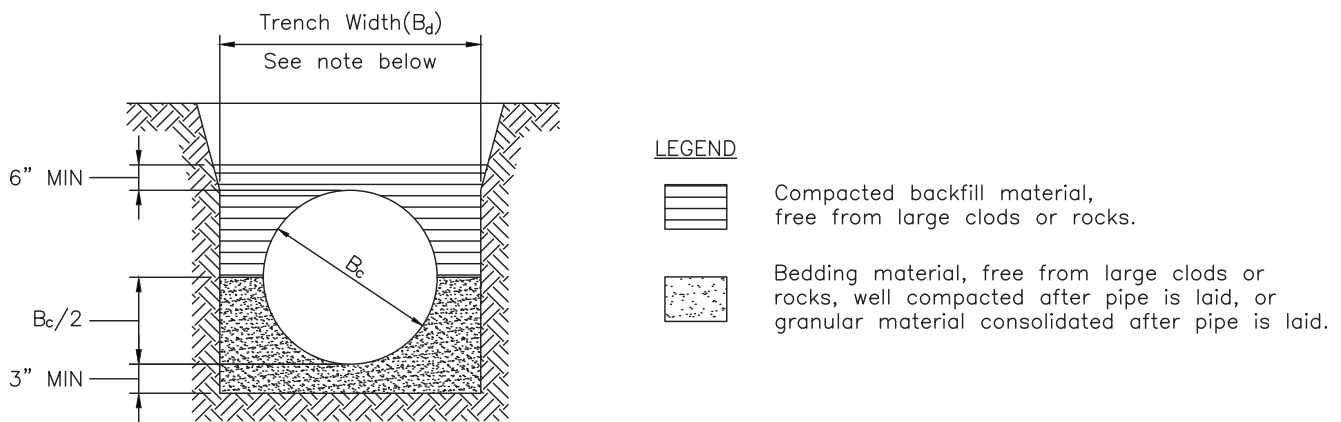

Trench Width

Trench width to be maintained from bottom to top of the pipe. The minimum specified trench width should allow sufficient access on each side of the pipe for any required consolidation of bedding under the pipe haunches. The minimum clearance between the pipe and the trench wall should be no less than 9 inches.

Figure 12-3

Using the parameters mentioned earlier, the pipe designer must determine the thickness of the steel cylinder and the size and spacing of the circumferential reinforcing rods. The AWWA C303 standard contains the minimum steel cylinder thicknesses that must be used for each pipe diameter. The minimum reinforcing rod diameter is also specified. A detailed example design for B-303 pipe is contained in Chapter 7 of the AWWA M9 Manual.

As with PCCP, the pipe design can be customized for each project resulting in economies for the owner.

FLOW FORMULAS

Over the years, many empirical flow formulas have been proposed. The Hazen-Williams formula, shown below, was first published by Allen Hazen and Gardner S. Williams in 1905 and continues to be the most widely used for pressure pipe systems.

$$V = 0.550 C_h d^{0.63} \left(\frac{h_L}{L}\right)^{0.54}$$

Where:

- V = Mean velocity, feet per second
- C_h = Hazen-Williams flow coefficient
- d = Inside pipe diameter, feet
- h_L = Head loss, feet
- L = Pipe length, feet

HYDRAULICS

FRICITION LOSSES AND ENERGY EFFICIENCY

Energy use in pipeline operation can be greatly reduced during the design stage. Head losses due to pipe wall friction are among the most manageable causes of energy consumption in pipeline operation. These losses can be minimized by specifying pipe with excellent long-term hydraulic characteristics, such as concrete pressure pipe, and by avoiding high flow velocities by selecting adequate pipe sizes.

A statistical analysis of 67 flow tests of concrete pressure lines was made by Swanson and Reed and published in the January 1963 AWWA Journal. Some of this pipe was manufactured as early as 1895.

This report presented a “best fit” mean deviation comparison with the well-known formulas by Hazen-Williams, Morris, Moody, and Scobey. The average mean deviation between calculated and observed losses was lowest for the Hazen-Williams formula. A regression analysis least-squares method was used to develop a correlation equation for the Hazen-Williams C /term, as follows:

$$C_h = 139.3 X 2.028d$$

The Hazen-Williams flow formula can be rewritten in a more convenient form where head loss is expressed in terms of flow velocity.

A flow diagram computed and arranged for a Hazen-Williams “ C ”/ value of 140 is presented in Figure 13-1. Conversion factors for other commonly used “ C ” values are included. The following illustrates the procedure to be followed in obtaining the loss of head in pipeline hydraulics using the Hazen-Williams chart:

$$h_L = 3.021 \frac{L}{d^{1.167}} \left(\frac{V}{C_h} \right)^{1.852}$$

Find the loss of head in 5,280 feet of 24-inch pipe when the discharge is 10 cubic feet per second.

On the flow chart, find the intersection of the pipe diameter line for 24-inch pipe and the discharge line of 10 cubic feet per second and follow the intersection to the bottom of the page to “head loss (feet per 1,000 feet).” This loss is 1.2 feet per 1,000 feet. Since the length given in the problem is 5,280 feet, the total loss is (5.28 x 1.2) or 6.34 feet.

The chart can also be used to determine flow, velocity, and required pipe diameters.

HEAD LOSSES DUE TO FITTINGS

While head losses due to fittings are generally a minor portion of the overall head loss in a pipeline, they can be important in certain applications such as treatment plants when the length of a line is short and the number of fittings is high. These head losses occur in elbows, reducers, enlargements, valves, and other fittings in the pipeline. The rational method of calculating these losses assumes full turbulence at those points and expresses the loss in terms of velocity head.

$$h_L = C_L \frac{V^2}{2g}$$

Where:

h_L = Head loss, feet

C_L = A dimensionless coefficient

g = Acceleration due to gravity, feet per second per second

Values of “ C_L ” commonly used for design purposes, along with a more comprehensive treatment of hydraulics, are included in AWWA Manual M9, Concrete Pressure Pipe.

FLOW OF WATER IN CONCRETE PRESSURE PIPEAS CALCULATED BY THE HAZEN-WILLIAMS FORMULA

Figure 12-4

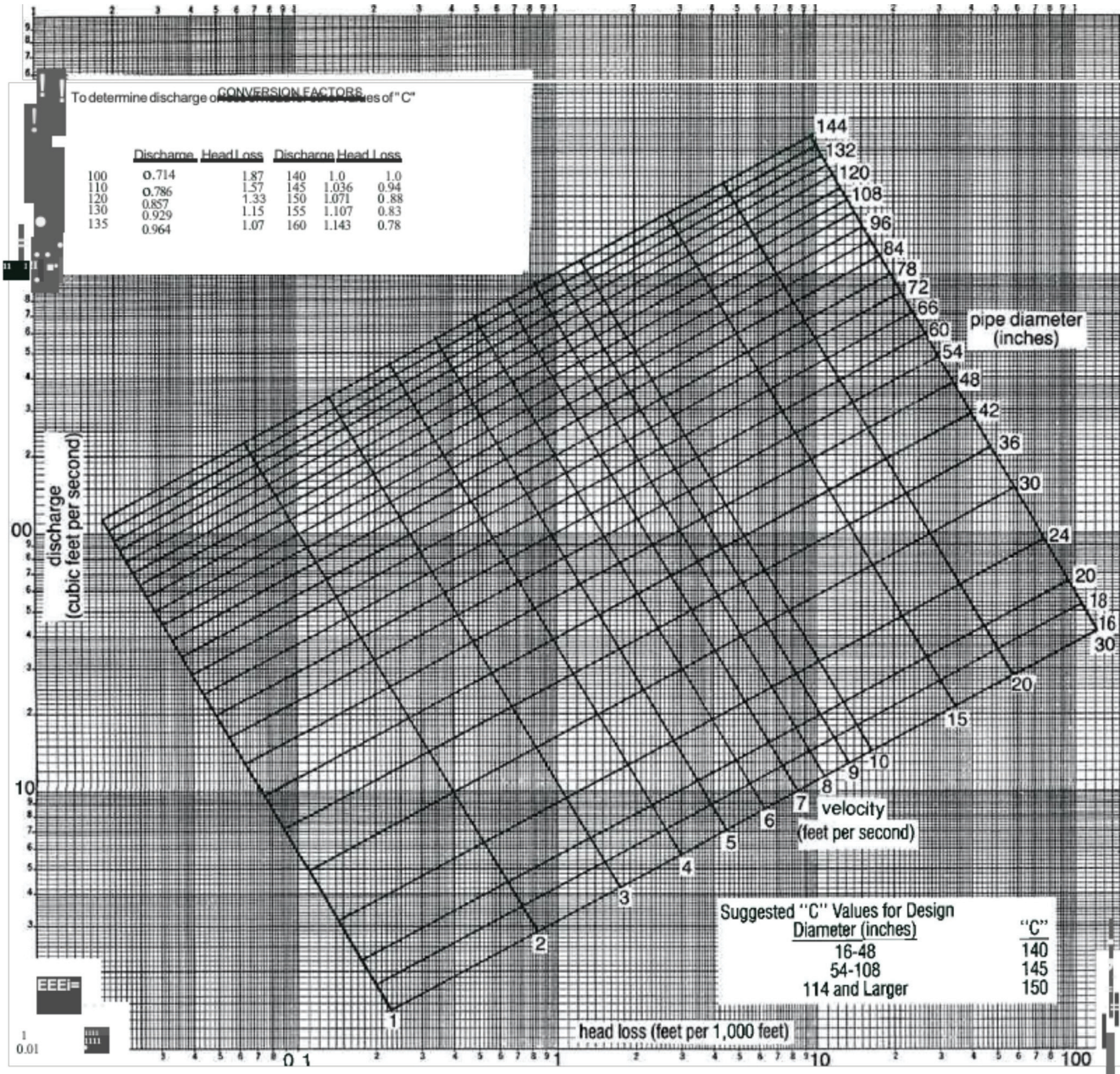



THRUST RESTRAINT

The thrust resulting from unbalanced forces which occur when a pipeline changes direction (deflected joints, elbows, etc.), changes size (reducers), or is terminated (bulkhead) must be restrained properly in order to prevent joints from opening sufficiently to cause leakage.

In the case of small changes in direction such as deflected joints and bevel joints, adequate resistance is frequently available from the weight of the individual pipe sections, the water in the pipe, and the earth cover over the pipe. For larger forces, it is usually necessary to use some form of thrust blocking or restrained joints.

Total thrust force is theoretically the sum of hydrostatic force and hydrodynamic force. Hydrostatic force is caused by the internal pressure in the pipe. Hydrodynamic force is caused by the changing momentum of water flowing in the pipe. Hydrostatic force exists even when water is not flowing, such as when a pipeline is being field tested, and greatly exceeds the hydrodynamic force for velocities commonly used in pressure mains. For the hydrodynamic force to equal the hydrostatic force created by just one pound per square inch of internal pressure, the velocity of the water in the pipeline would have to be 8 feet per second.

SMALL DEFLECTIONS

Small changes in direction caused by deflected and/or beveled joints usually do not require added provisions for thrust restraint such as restrained joints or thrust blocks.

In the case of a downward vertical curve, the resultant thrust can be conservatively considered as acting straight up. The vertical resisting force is the earth load over the pipe, the weight of pipe, and the water in the pipe.

For a long radius horizontal curve negotiated using bevel pipe, joint openings, or a combination of the two, resistance to horizontal movement is provided by friction at the top and bottom of the pipe and by soil bearing pressure against the back side of the pipe.

For an upward curving vertical curve, the resultant thrust force is downward, and is resisted by the bearing resistance of the bedding. For properly bedded pipe, there is seldom any need to supply added thrust restraint for this situation.

LARGE DEFLECTIONS AND LARGE THRUSTS

Thrust Block Method

The resultant thrust force (T) at elbows is defined by Equation 13-1 and is shown in Figure 13-3A. For a bulkhead, the thrust force is PA as shown in Figure 13-3B. At a tee, the force is PA_B where A_B is the cross sectional area of the branch line as shown in Figure 13-3C. For a reducer, the thrust force is $P(A_1 - A_2)$ as shown in Figure 13-3D.

Added thrust restraint is usually required for fittings such as these.

One method to provide this restraint is thrust blocking, which involves the field placement of concrete between the fitting and the trench walls. Typical thrust block shapes for the common fittings shown in Figure 13-3 are shown in Figure 13-4. The thrust block transfers the thrust into the trench walls and must be designed such that the bearing pressure at the face of the block does not exceed the bearing capacity of the soil.

Knowledge of the bearing capacity of the undisturbed soil in the trench walls is important in designing thrust blocks. Table 13-3 gives typical allowable soil pressures for several general soil types. The typical thrust blocks shown in Figure 13-4 and the allowable soil pressures shown in Table 13-3 apply when the resultant thrust force (T) is horizontal or downward.

When the thrust is upward, the total weight of the fitting, the water in the fitting, the soil above the fitting, and the thrust block must exceed the vertical component of the thrust.

TABLE 13-3 – ALLOWABLE SOIL PRESSURES

Soil Type	Minimum	Maximum
	Short tons per square foot	
Quicksand; alluvial soil	0.5	1
Soft clay	1	2
Wet clay; soft wet sand	1	2
Moderately dry sand; fine sand, clean and dry	2	3
Clay and sand in alternate layers	2	3
Firm and dry loam or clay; hard dry clay or fine sand	2	5
Compact coarse sand; stiff gravel	3	6
Coarse gravel; stratified stone and clay; rock interior to best brick masonry	5	8
Gravel and sand well cemented	6	40
Good hardpan or hard shale	6	40
Good hardpan or hard shale unexposed to air, frost, or water	10	15
Very hard native bedrock	15	25
Very hard native bedrock, in thick layers under caisson	30	

American Civil Engineers Handbook, Merriman & Wiggan, 5th edition, 11th printing, John Wiley & Sons, New York, Page 711

RESULTANT THRUSTS AT COMMON FITTINGS

**Figure 13-3A
Elbow thrust**

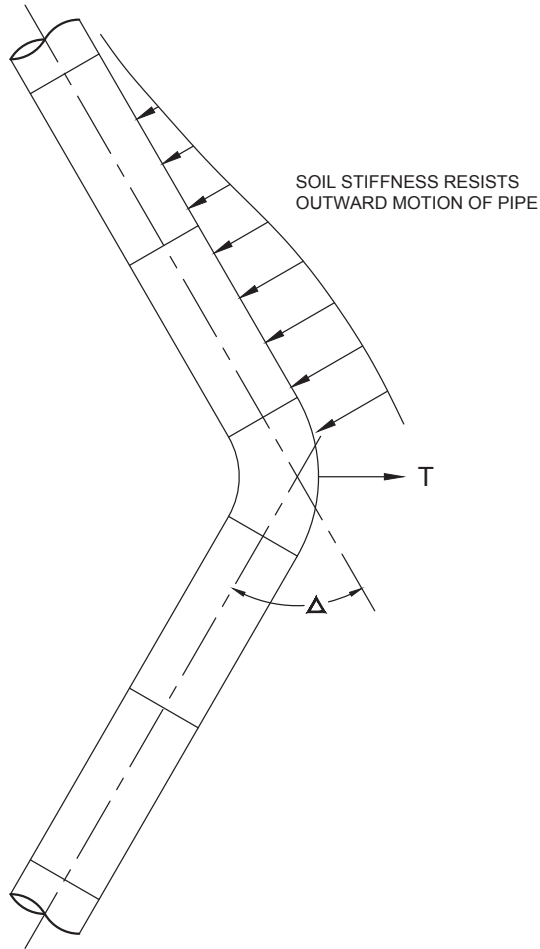

Figure 13-3B - Bulkhead thrust

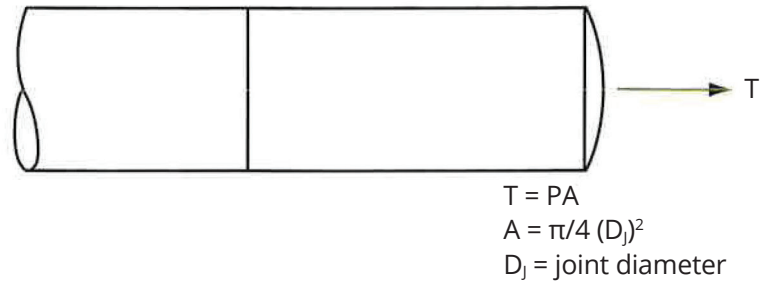

Figure 13-3C - Tee thrust

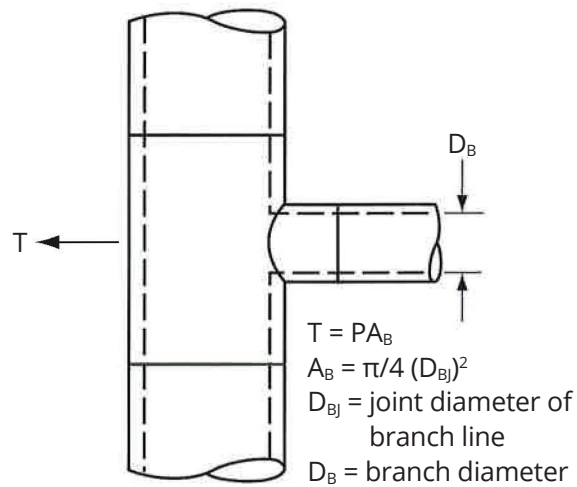
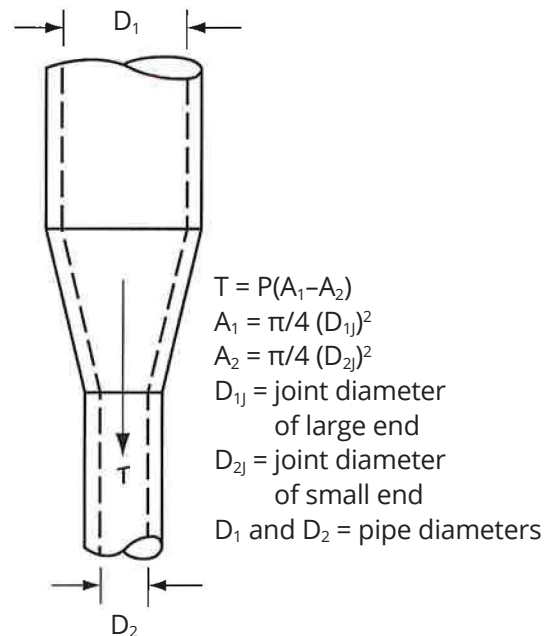

Figure 13-3D - Reducer thrust



TYPICAL THRUST BLOCK CONFIGURATIONS

Figure 13-4A - Elbow

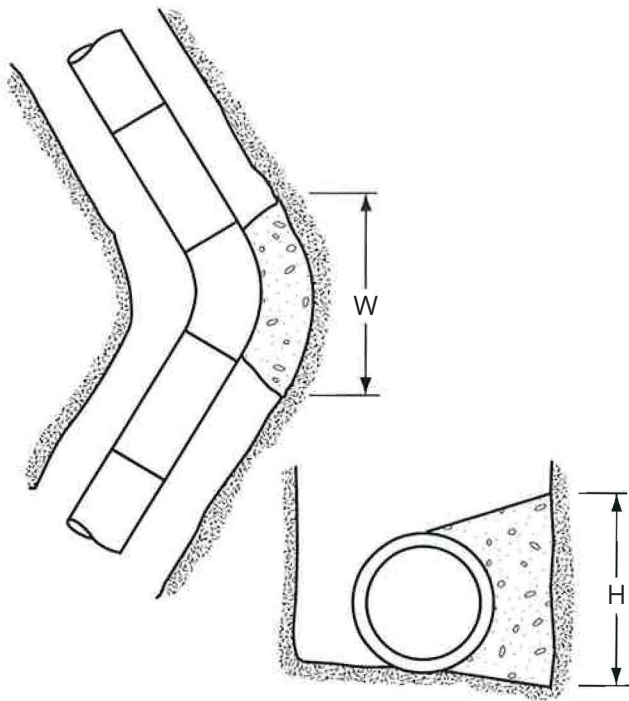

Figure 13-4B - Bulkhead

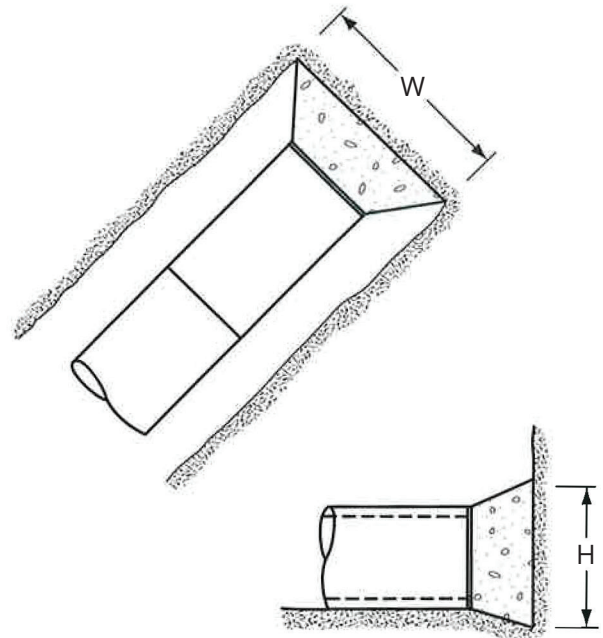

Figure 13-4C - Tee

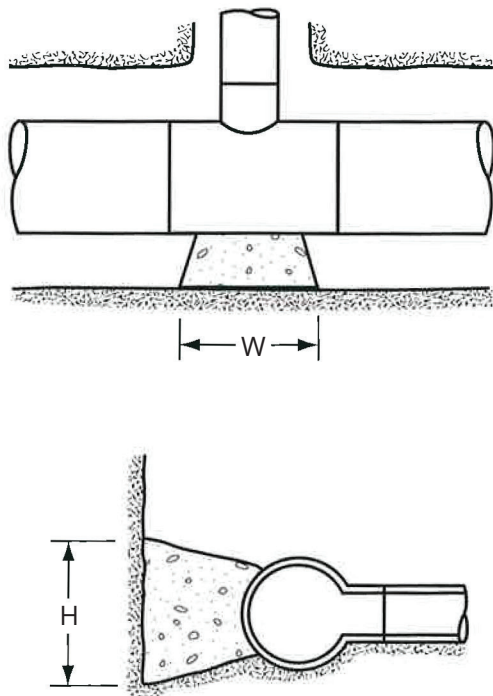
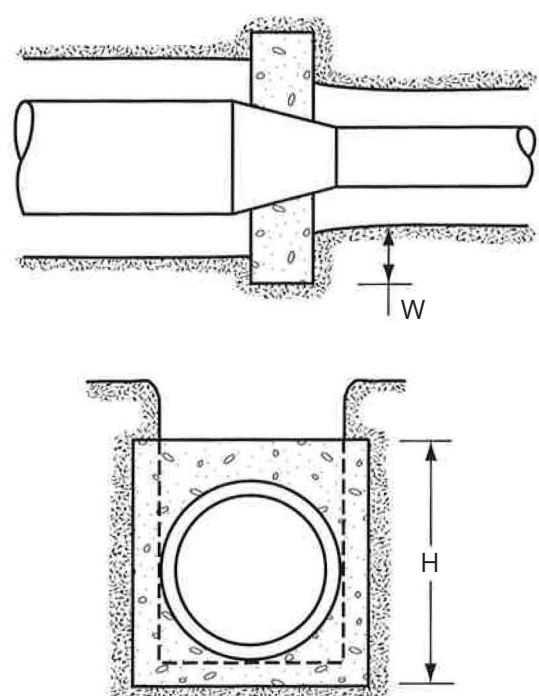

Figure 13-4D - Reducer



RESTRAINED JOINT METHOD

Conditions at a fitting which produce a horizontal thrust force may not be conducive to the use of a thrust block. Problems such as poor soil bearing capability, congestion from other nearby utilities or structures, or the possibility of future excavation behind the thrust block are examples of problems that must be considered.

When such conditions are anticipated, restrained joints are frequently used to transmit the thrust force into the surrounding soil by means of frictional resistance between pipe and soil.

Restrained joints are used to “tie” (harness) enough pipe to the fitting to create a frictional “drag” to offset the thrust force created at the fitting.

The method for calculating the requirements for restrained pipe is described in the AWWA M9 Manual, Chapter 9. (Refer to Section 13 for a continuation of this discussion.)

THRUST RESTRAINT FOR REDUCERS – FIGURE 13-5

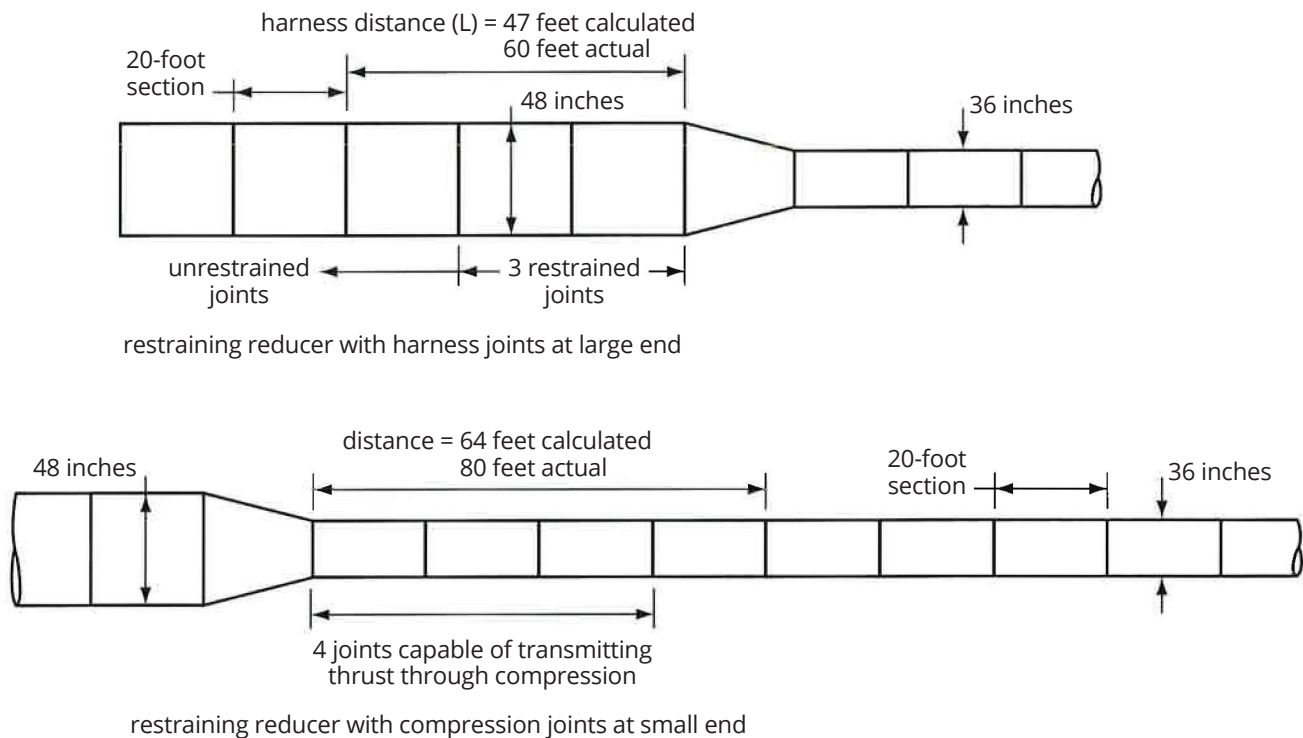

RESTRAINED JOINTS

There are basically three types of restrained joints available from Thompson Pipe Group. Two are of a mechanical nature and the third is a field welded joint.

The Snap Ring® restrained joint is shown in Section Four. In general, it is the most economical joint to install in the field, being completely self contained and requiring only one bolt. The harnessed clamp joint is also shown in Section Four. The bell and spigot rings for this joint are supplied with factory installed harness rings which are restrained by a harness clamp supplied in two semi circular halves which are bolted together after the joint is assembled in the field.

A welded joint (as shown in Figure 13-6) can also be used to transmit thrust, but in general is less economical than a mechanically restrained joint due to the costs of field welding. This welded detail or other similar variations are used by Thompson as shop-welded joints to join multiple units of pipe or fittings together when the field installation of longer pieces is desirable.

WELDED TYPE TIED JOINT - FIGURE 13-6

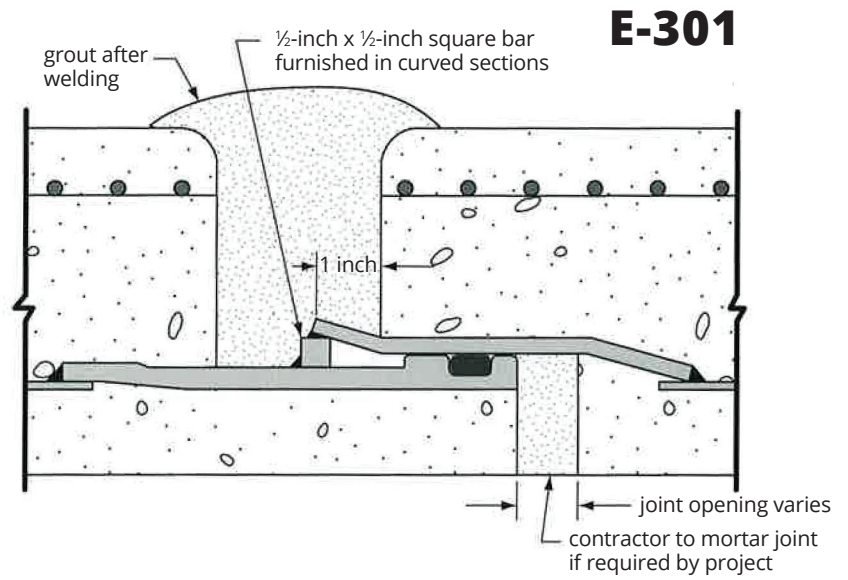
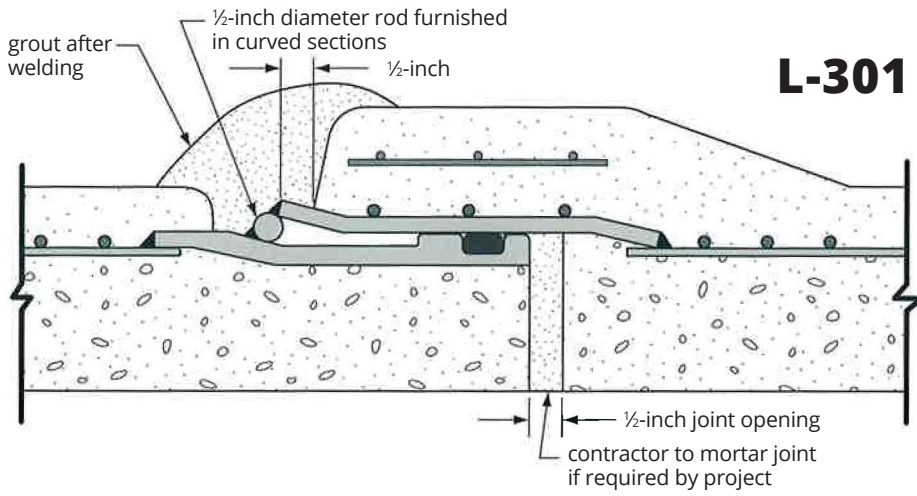

ANCHOR RING PIPE

Occasionally, restraint of a fitting by a combination of restrained joints and thrust collars is preferred. Such a detail is shown in Figure 13-7. Pipe which will have thrust collars cast around them in the field should be made as anchor ring pipe.

One example is a two-ring anchor pipe as shown in Figure 13-8.

ELBOW RESTRAINT WITH THRUST COLLARS AND RESTRAINED JOINTS - FIGURE 13-7

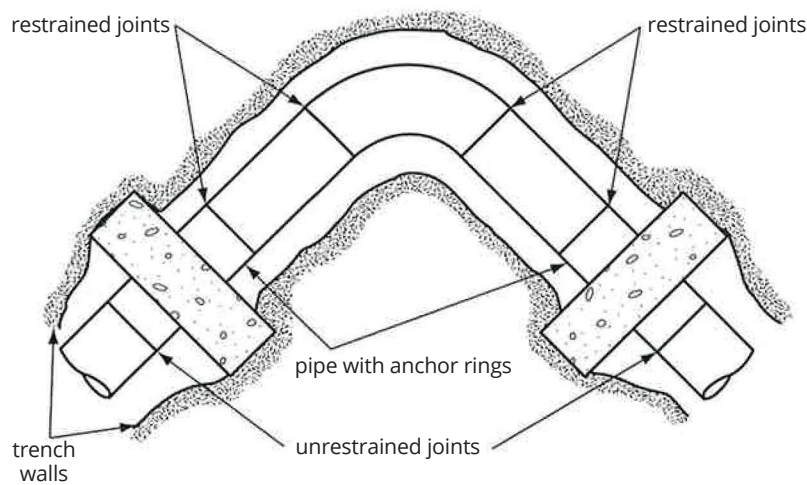

ANCHOR RING PIPE - FIGURE 13-8

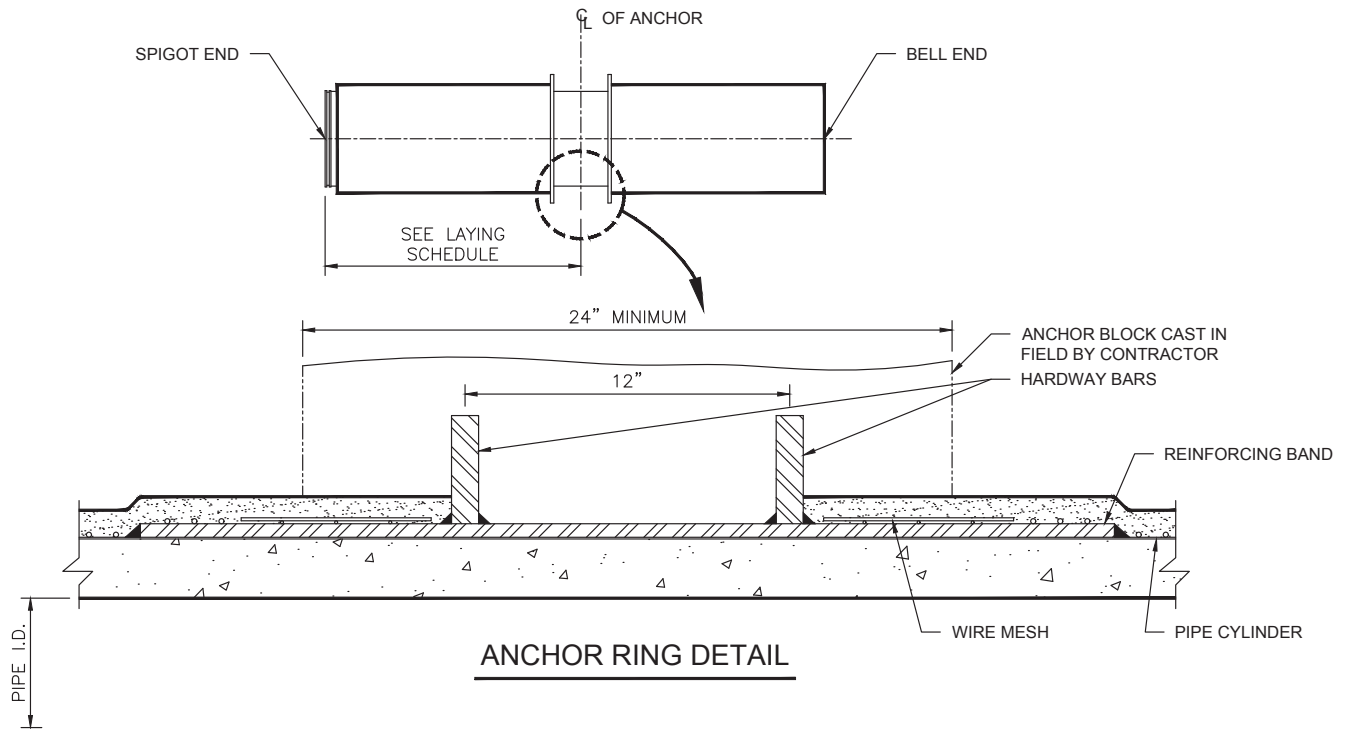

NOTE:

- 1) ALL EXPOSED STEEL PAINTED WITH PROTECTIVE COATING.

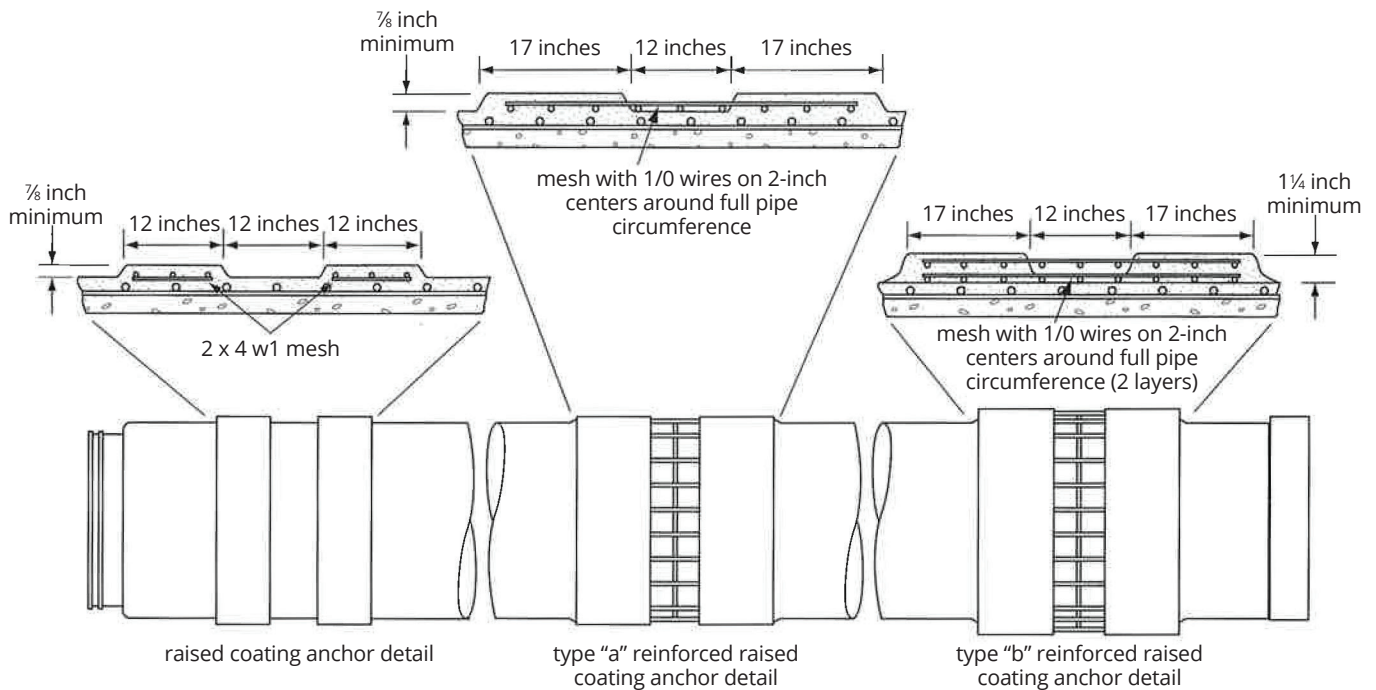

THRUST RESTRAINT DESIGN PROGRAM

The method for calculating the requirements for restrained pipe is described in the AWWA M9 Manual, Chapter 9. The procedure for determination of restrained joint distances and heavy gauge steel cylinder requirements for both PCCP and B-303 pipe was updated with the issuance of the 2008 M9 Manual. This procedure is based on a significantly more precise finite element analysis for determining the bending moments, thrust forces, and shear forces and the resulting stresses and strains that occur in pipe connected to an elbow fitting. Up until 2008, this process was based on approximations for not just concrete pressure pipe but other types of pipe as well. Since the procedure does not lend itself to hand calculations, a computer program was developed. This program is available for a free download from the American Concrete Pressure Pipe Association website (www.acppa.org). An instructional manual for using the program can also be downloaded from the website or requested from Thompson Pipe Group. The program is called Thrust Restraint Design Program (abbreviated TRDP). This program is also used by the Thompson Pipe Group Engineering staff in developing layout schedules.

The program requires various input parameters. An example of the first screen of the program is shown in Figure 1. It's helpful if a new user of the program contacts Thompson Pipe Group for assistance with the various inputs and how to obtain and use the program outputs.

One important aspect of the program is the use of passive soil resistance behind the elbow and the pipe connected to the elbow. This requires a selection of the soil type in the input screen ("Soil Information"). Chapter 9 in the M9 Manual includes a chart detailing the characteristics of five, different soil types denoted as I, II, III, IV, and V. Once the soil type selection is made from the drop-down menu, the remaining input boxes are filled with the default values. The most common soil type used in these calculations is Type III. However, it may be necessary to conduct a detailed geotechnical investigation for a given project to ensure the proper soil type is used. The transient pressure must be entered as the pressure over and above the working pressure.

Figure 2 illustrates a completed input screen ready for an example calculation. Note that the Bend Length block requires input of the elbow leg laying length. This dimension is the distance from the Point of Intersection (PI) of the elbow out to the joint on one leg. This length can be found in the section on Elbows. Select Next and Figure 3 shows the Calculation Progress screen. The input must be saved by pushing the Save Input and then push Begin Analysis to start the computation process.

Figure 4 shows the TRDP Print Options screen where the user can choose how to output the computation results; view on screen or print.

Figure 5 displays the results of the analysis. The input parameters are included along with the length of restrained joint pipe that must be connected to each leg of the elbow. If any heavy gauge steel cylinder is needed (for example, thicker than the standard gauge cylinder for the pipe type being analyzed), the footage of each thickness will also be shown.

Note that up to six different elbows or thrust conditions can be input for analysis in each run of the program. Full bulkhead conditions (such as at a hydrostatic test plug or cap) can also be analyzed using the TRDP program. In this case, enter zero into the Bend Angle and Bend Length blocks in the Input Screen. Custom degree for elbows can also be entered by hand in the input screen.

TRDP Input

TRDP v1.1

Project Information

Project Name

Location

Designer

Company

Load Input

Load Results

Next

Exit

Pipe Type

ECP

LCP

BWP

RCP

Pipe Properties

Inside Diameter in.

Core Thickness in.

Steel Cylinder OD in.

Min. Steel Cyl. Thickness in.

Mortar Thickness in.

Pipe Weight lb/ft

Pressure

Working Pressure, Pw psi

Transient Pressure, Pt psi

Field Test Pressure, Pft psi

Material Properties

fy psi

fc psi

Soil Information

Soil Type

Soil Stiffness, k psi

Unit Weight of Soil, γ_s pcf

Coefficient of Friction, μ

Friction Angle, ϕ deg

Submerged Soil

Joint Type

Welded

Mechanically Harnesssed

Joint Diameter in.

Bend Information

Description	Bend Angle (deg)	Bend Length (ft)	Pipe Laying Length (ft)		Soil Cover (ft)
			First	Typical	
1	<input style="width: 50px;" type="text"/>	<input style="width: 50px;" type="text"/>	<input style="width: 50px;" type="text"/>	<input style="width: 50px;" type="text"/>	<input style="width: 50px;" type="text"/>
2	<input style="width: 50px;" type="text"/>	<input style="width: 50px;" type="text"/>	<input style="width: 50px;" type="text"/>	<input style="width: 50px;" type="text"/>	<input style="width: 50px;" type="text"/>
3	<input style="width: 50px;" type="text"/>	<input style="width: 50px;" type="text"/>	<input style="width: 50px;" type="text"/>	<input style="width: 50px;" type="text"/>	<input style="width: 50px;" type="text"/>
4	<input style="width: 50px;" type="text"/>	<input style="width: 50px;" type="text"/>	<input style="width: 50px;" type="text"/>	<input style="width: 50px;" type="text"/>	<input style="width: 50px;" type="text"/>
5	<input style="width: 50px;" type="text"/>	<input style="width: 50px;" type="text"/>	<input style="width: 50px;" type="text"/>	<input style="width: 50px;" type="text"/>	<input style="width: 50px;" type="text"/>
6	<input style="width: 50px;" type="text"/>	<input style="width: 50px;" type="text"/>	<input style="width: 50px;" type="text"/>	<input style="width: 50px;" type="text"/>	<input style="width: 50px;" type="text"/>

Figure 1 – Input Screen for the TRDP Program

TRDP v1.1

Project Information

Project Name:

Location:

Designer:

Company:

Pipe Type

ECP

LCP

BWP

RCP

Pipe Properties

Inside Diameter: in.

Core Thickness: in.

Steel Cylinder OD: in.

Min. Steel Cyl. Thickness: in.

Mortar Thickness: in.

Pipe Weight: lb/ft

Pressure

Working Pressure, Pw: psi

Transient Pressure, Pt: psi

Field Test Pressure, Pft: psi

Material Properties

fy: psi

fc: psi

Soil Information

Soil Type:

Soil Stiffness, k: psi

Unit Weight of Soil, γ_s : pcf

Coefficient of Friction, μ :

Friction Angle, ϕ : deg

Submerged Soil

Joint Type

Welded

Mechanically Harnesssed

Joint Diameter: in.

Bend Information

Description	Bend Angle (deg)	Bend Length (ft)	Pipe Laying Length (ft)		Soil Cover (ft)
			First	Typical	
1 Station 100+50.00	45	1.77	20	20	6
2					
3					
4					
5					
6					

Figure 2 – Completed Input Screen Example

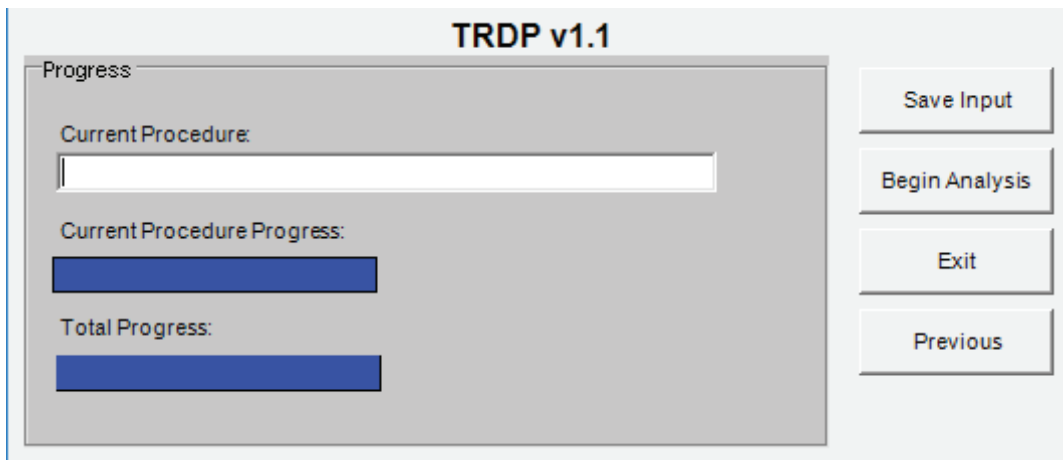

Figure 3 – Calculation Progress Screen

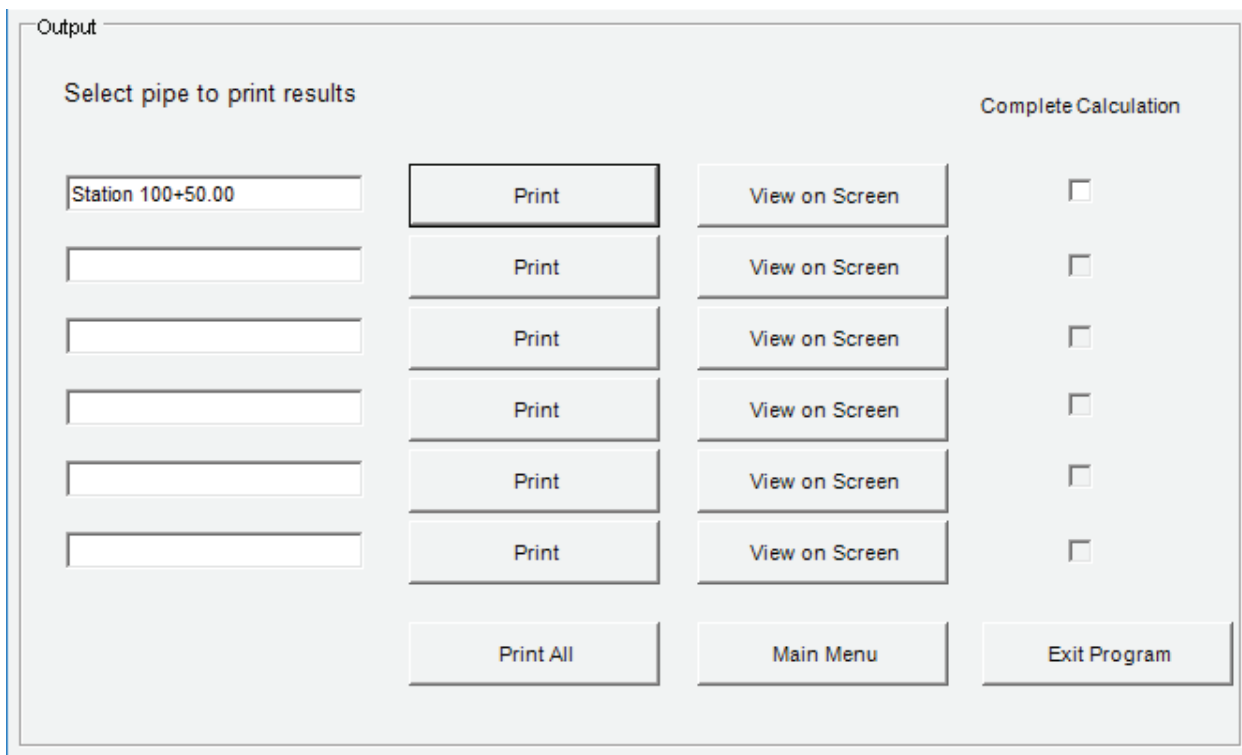

Figure 4 – TRDP Print Options Screen

PROGRAM TRDP v1.1
PROJECT Main Street Pipeline
LOCATION Anywhere USA
DESIGNED BY John Doe
CHECKED BY
COMPANY Thompson Pipe Group
DESCRIPTION Station 100+50.00

Sheet no. 1 of 1
Date 11/12/2020

Pipeline Information

Pipe Type (ECP, LCP, BWP, RCP)	LCP	Cylinder Outside Diameter, D_y	40.5 in.
Internal Diameter, ID	36 in.	Minimum Cylinder Thickness	0.0598 in.
Core Thickness, h'_c	2.25 in.	Bend Angle, Δ	45 deg
Mortar Coating Thickness, h_m	1 in.	Centerline Length of Fitting, L_b	1.77 ft
Core Outside Diameter, OD	40.5 in.	Pipe Laying Length (First Pipe), L_{p1}	20 ft
Pipe Outside Diameter, D_o	42.5 in.	Pipe Laying Length (Typical Pipe), L_p	20 ft

Joint Properties

Joint Type (Welded or Harnessed)	Harness
Joint Diameter, D_j	41 in.
Joint Slack	0.0625 in.

Material Properties

Concrete Strength, f'_c	4500 psi
Steel Cylinder Yield Strength, f_{yy}	36000 psi

Pressures

Working Pressure, P_w	125 psi
Transient Pressure, P_t	50 psi
Field Test Pressure, P_{ft}	150 psi
$P_{weff} = \max(P_w, P_{ft}/1.25, (P_w + P_t)/1.4)$	125 psi

Soil Information

(Table 9-1 - Soil Type Selection Guide)

Soil Type (I through V)	III
Soil Stiffness, k	1900 psi
Soil Unit Weight, γ	114 pcf
Pipe to Soil Friction Coefficient, μ	0.5 in.
Soil Cover, H	6 ft
Angle of Internal Friction, ϕ	30 deg

Bend Angle (deg)	Centerline Length of Fitting (ft)	Thrust (kip)	Total Footage Required (one side)	Total Heavy Gage Footage (one side)
45	1.77	158	29	0

Required Lengths for One Side

Cylinder Thickness (in.)	0.5	0.4375	0.375	0.3125	0.25	0.1875	0.1644 (8 GA)	0.1345 (10 GA)	0.1046 (12 GA)	0.0747 (14 GA)	0.0598 (16 GA)
Length Needed (ft)	0	0	0	0	0	0	0	0	0	0	28.6
Number of Pipes	0	0	0	0	0	0	0	0	0	0	2

Figure 5 – Computation Output Screen



SPECIAL CONCRETE PRESSURE PIPE APPLICATIONS

Double Wrap and Coat (DWC) for L-301 and E-301 Pipe

Occasionally, certain loading situations are encountered where it is impossible to attain sufficient pipe strength with one layer of prestressing wire. These loading conditions are generally external and result from very high earth fills. One way to add compression into the core and obtain greater pipe strength is to apply a second layer of prestressing wire over the mortar coating surface. A second mortar coating is then applied to provide protection over the second prestressing layer. In general, this is not necessary until earth covers exceed 20 to 30 feet with ordinary bedding. With improved bedding conditions, it is not necessary to go to double wrap and coat pipe until even greater fill heights are reached. The Thompson Pipe Group engineering staff can help determine whether this type of pipe is needed for a specific set of conditions.

Heavy Wall Pipe (HW) for L-301 and E-301 Pipe

For earth loads beyond the capacity of double wrap and coat pipe, there is another method for increasing pipe strength. Thicker cores can be produced to provide more concrete for prestressing and greater pipe strength. Heavy wall pipe can be either single wrapped and coated or double wrapped and coated as necessary to meet loading conditions. Thompson welcomes inquiries during the preliminary design stages of projects involving very high covers since equipment availability or shipping restrictions due to both weight and dimensions that can affect the planning of a particular project.

Buoyancy

The possibility of flotation of a pipeline must always be considered in the design of a subaqueous line. Buoyancy conditions should be considered with the pipeline empty, unless such conditions are impossible. The following observations are based on the experience of several consultants:

1. Pipelines with a bulk specific gravity of 0.5 or less will work their way through fine sand such as beach sand.
2. Pipelines with bulk densities between that of water and sand will have little or no tendency to ascend through fine sand.
3. If a pipeline is buoyant in water, it is likely to float out of sand or silt that is subject to wave action.
4. If a pipeline is buoyant in a liquified sediment, then agitation of the sediment will cause the pipe to rise. Cyclic changes in bottom pressure caused by storm waves can sometimes liquify slightly cohesive material and cause flotation. The same effect can also be caused by a variable water table, underground percolation, and unstable clay that is subjected to high water content.
5. If a pipeline is to float, then the sediment must act like a fluid, and the bulk specific gravity of the pipeline must be less than the specific gravity of the sediment.

Dead weight is generally the most practical method of anchoring offshore pipelines, with coarse backfill material most commonly used. Pipelines with heavy walls may also be used to overcome buoyancy.

The required wall thickness (t) necessary for the pipe weight to equal the buoyant force (with no backfill) using normal weight concrete in fresh water is:

$$t = 0.3085 R$$

Where:

R = inside pipe radius, inches

For pipe in sea water, the wall thickness necessary for the pipe weight to equal the buoyant force is:

$$t = 0.3206 R$$

If additional safety factors are deemed necessary, refer to the AWWA M9 Manual, Chapter 11 for further information.

SUBAQUEOUS CONCRETE PIPELINES

Subaqueous pipelines involve more complexity and challenge to the engineer and contractor than most other types of pipeline construction. For additional information, refer to the AWWA M9 Manual, Chapter 11.

These lines, located in fresh, brackish, and salt water, cover a wide range of applications:

- water or sewer lines crossing under rivers, estuaries, or inland lakes;
- industrial cooling water intake and discharge lines;
- treated sewage outfalls; and
- intake pipe for industrial or municipal water supply.

The two major sections of construction of an ocean outfall are:

- the on- or near-shore section, and
- the off-shore section.

Each of these sections has its own specific problems and construction techniques.

On- or Near-Shore Sections

These sections are affected by both wave and tidal actions and are the most critical from the standpoint of potential external forces and influences on the pipe. For this reason, these sections are always buried. Conventional construction procedures are followed on the dry land section until the beach and surf areas are reached. From this point a temporary trestle, pier, or cofferdam can be built to handle the excavating and pipe handling equipment.

Icing conditions combined with wave action can produce tremendous loadings on the near-shore sections of the line and must be considered in design in less temperate areas such as the Great Lakes.

River crossings involve special engineering considerations. Stream data regarding flow velocity and depth of scour in the river bed are invaluable in designing a safe and economical crossing. Scour is a major problem to be considered, and it should be recognized that scour increases locally after the bed is eroded to the top of the pipe. This problem is generally so unpredictable that positive means should be employed to overcome buoyancy. If bank recession is occurring, provision should be made for extra cover during the proposed life of the pipeline.

Off-Shore Sections

There are no clear-cut answers to the best method for constructing offshore pipelines. For large enough projects, special equipment can be justified.

Construction frames or towers are also used for depths from 30 feet to approximately 80 feet. These rest on the sea floor to provide a stable laying platform and must be moved with a derrick barge.

For depths beyond 80 feet, present methods often utilize floating equipment. Long strings of pipe can be handled this way by use of pontoons or other means of closely controlling the lowering of the pipe. Control techniques for line and grade beyond feasible limits for shore control or bottom-supported laying platforms frequently consist of survey towers, specially anchored buoys, and guyed risers on the pipe.

Pipe Assemblage

In recent years the Hydro-Pull system has been used to join pipe under water. A bulkhead with a high volume pump built into it is attached to the end of the pipe to be laid. The pump evacuates water at a rate sufficient to create a pressure differential which is great enough to force the joint together.

The length of pipe which may be made up above water depends largely on the capacity of handling equipment. Such intermediate joints made above water may be welded or conventionally joined, depending on the required flexibility of the line and the method of handling the string. These strings are then lowered as a unit and the underwater joints made.

Diffusers

Concrete pressure pipe offers a wide variety of options and opportunities for diffusing flow in your outfall. Contact Thompson to discuss your options.

PILE SUPPORTED PIPE

Prestressed lined cylinder, embedded cylinder pipe, and bar-wrapped cylinder pipe manufactured by Thompson Pipe Group can be readily designed in conjunction with pile supports whether required by soil conditions or for aerial installation.

The AWWA M9 Manual, Chapter 10, contains detailed information regarding the design and construction of pile supported pipelines. If internal pressure is involved, this must be taken into consideration along with the external loads.

Engineering/technical service personnel at Thompson are available to discuss this design procedure.

Tunnel Installations

Tunnel installations include various construction methods used to place underground pipelines without open excavation at grade.

Concrete pressure pipe can be placed under streets or other objects by boring a tunnel under the obstacle, and then lining the tunnel with concrete pressure pipe.

Primary Liners

Large tunnels (5 feet or larger) in clay or granular material will normally require the use of a tunnel shield at the face. With a shield it is necessary to install a primary lining (or casing) of sufficient strength to support the surrounding earth. The annular space behind the liner is filled with a cement grout or a lubricating grout as the tunneling and installation of primary lining progresses. Connections for pumping the grout should be provided in the primary liner.

Primary liners are usually made of steel, precast reinforced concrete segments, rib and lagging, reinforced concrete pipe, fiberglass or steel pipe. Short sections of precast concrete oval rings called tunnel liner segments are also used. Their dimensions allow for movement through previously laid sections to the tunnel heading, where they are joined with the previously placed section.

Finish Liners

When mined tunnels need to be watertight or if they must operate under pressure, concrete pressure pipe as a finish liner or carrier pipe can satisfy both requirements. In rock tunnels not requiring a primary liner, concrete pressure pipe may be installed as the finish liner.

Grout connections can be built into the pipe wall for easy filling of the annular space between the pipe and the tunnel excavation. Concrete pressure pipe is used as the finish liner or carrier pipe in tunnels that have been mined with the primary liners placed as the excavation progresses.

Installation

A variety of techniques can be used for transporting or moving concrete pipe into or through the tunnel liner. The methods vary from a simple skidding arrangement to special pipe-carrying machines that not only transport the pipe but also position and join a section of pipe to the one previously placed.

For most projects, raised mortar coating skids on the pipe exterior will normally be the most economical method for moving the pipe in the tunnel. These skids protect the pipe barrel and the joint areas from damage as the pipe is moved into the tunnel. Refer to Figures 1, 2, and 3.



Figure 1: Raised mortar coating skids on L-301 pipe

Grouting

If grout or sand is to be placed in the primary liner or the tunnel surface, the best way is to use pumping or pneumatic placing equipment suitable for handling the mixture. Grouting should not take place until the line has been pressure tested. Precautions must be taken to prevent flotation of the carrier pipe within the liner while the concrete, mortar, or grout is still fluid.

If the annular space between the carrier pipe and the primary liner does not require concrete or mortar, the individual pipe joints should be covered with a grout band and grouted as the pipe is being pushed into the tunnel. When the joints are connected in the jacking pit and pushed through the liner, it is advisable to support the grout band over its bottom 270 degrees with sheet metal or rubber belting to prevent the filled grout band from rubbing or snagging on the invert of the liner. A retarder is recommended for the grout mix to delay its setting until the tunnel pipe is in its final position.

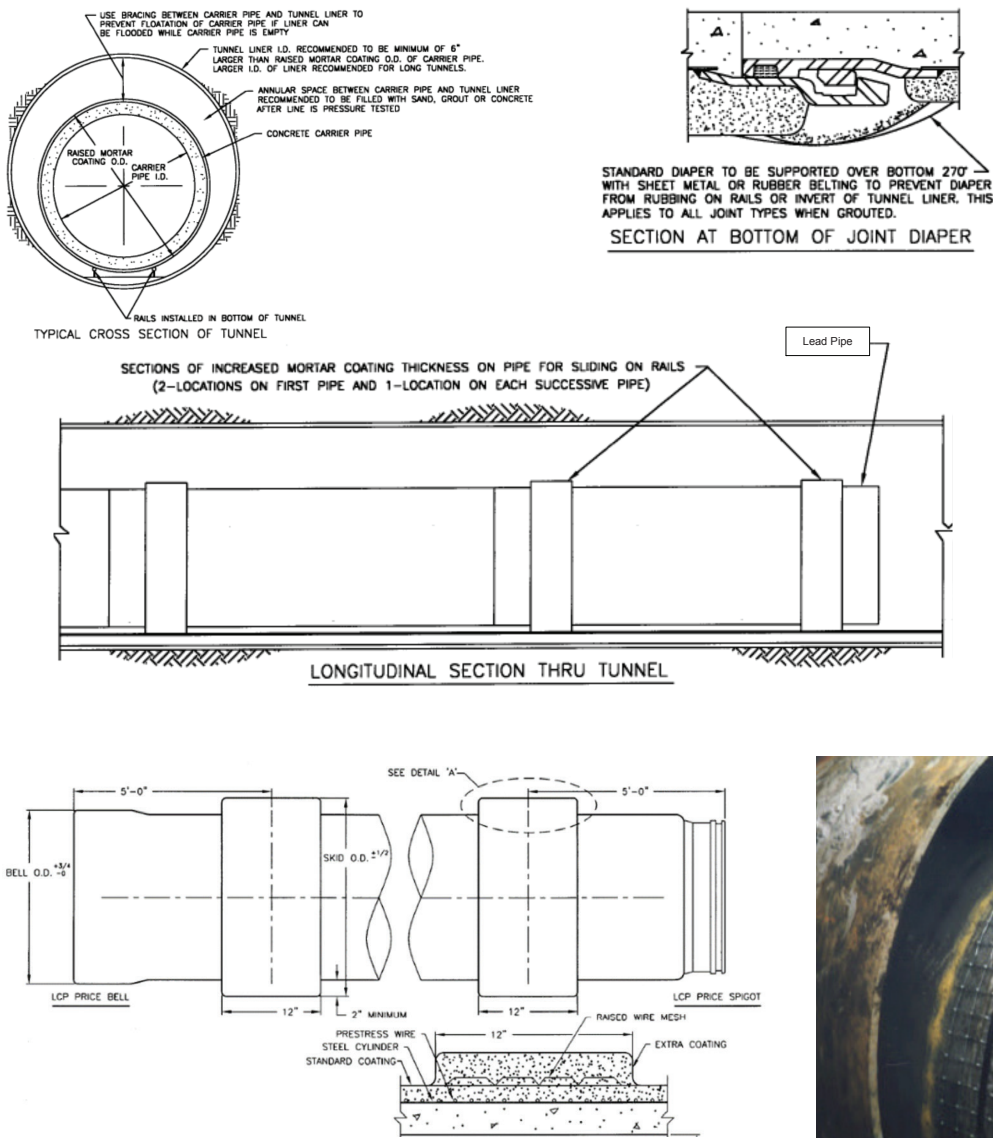

Figure 2: Typical use of raised mortar coating skids. The lead pipe will have two skids installed and following pipe will have one skid on the trailing end.

Figure 3: Approximate dimensions of raised mortar coating skids.



Figure 4: Light gauge steel mesh wrapped around the joint to support the wet grout in the grout band.

Jacking

Pipe jacking is a specialized method of tunnel installation that requires individual consideration. Call Thompson Pipe Group to supply AWWA C300 or AWWA C302 pipes to meet a jacking or microtunneling requirement.

TREATMENT PLANT PIPING

Water and wastewater treatment plants are designed to treat a broad spectrum of water inflows. These may include aggressive natural waters, highly septic sanitary sewage, and a wide range of chemicals and industrial waste materials.

With its dense concrete lining, concrete pressure pipe is suited for these installations, but it may be necessary to line the interior to protect against aggressive flows.

Functional requirements and space limitations associated with modern treatment plants dictate extreme versatility of fittings and specials for the piping material used.

The distribution headers and piping galleries of both types of treatment plants are particularly suited to concrete pressure pipe.

With a wide range of tees, wyes, elbows, and reducer sections available, the customizing ability of concrete pressure pipe provides a product that will meet the most exacting requirements.

The humid environments of interior piping galleries can induce atmospheric corrosion of ferrous piping materials. Concrete pressure pipe thrives in a humid environment; with this exposure cement rich mortar coatings increase in strength.

The corrosion-inhibiting properties of mortar coated concrete pressure pipe are well known. The cement-rich mortar coating places the steel components of the pipe into a passive state with respect to corrosion. The alkaline environment provided by the coating yields a pH value of approximately 12.5 around the steel. Documented research has shown that steel assumes passive characteristics with regard to corrosion when surrounded by an alkaline environment having a pH value of 10.5 or greater.

The standard joint used with concrete pressure pipe is the steel bell and spigot ring with confined O-ring rubber gasket. This self centering joint provides ample flexibility to absorb normal settlement experienced in yard piping installations around treatment plants. When thrust restraining is required, a number of welded and mechanically restrained joints are available to transfer axial pressure thrusts. The mechanically restrained joints, such as the Snap Ring® and harness clamp type (see Section 4), provide some degree of flexibility for treatment plant installations. Standard mechanical and Victaulic couplings, as well as flanges, readily adapt to concrete pressure pipe (see Section 10). These couplings enable concrete pressure pipe to be joined to a variety of valves and pumping equipment.



CONCRETE PRESSURE PIPE TAPPING SYSTEMS

Tapping prestressed concrete pressure pipe and bar-wrapped concrete pressure pipe is a common occurrence in today's public works projects. The Thompson Pipe Group Pipeline Services staff is fully equipped to provide the technical expertise, material, and installation services to make service taps up to 48 inches in diameter (and larger under certain circumstances) on any type of pressure pipe. In most cases, this work can be done under pressure without interrupting service to customers.

Thompson stocks tapping saddles and valves for 3/4-inch to 2-inch threaded connections and most common flanged tapping connections. We fabricate tapping sleeves for all sizes and types of pipe and all sizes of taps. These readily available tapping assemblies provide a secure and economical means of making large diameter taps.

Threaded Pressure Taps

Tapping saddle assemblies can be supplied which have been drilled and threaded to match AWWA standard threads (CC) or standard iron pipe threads (NPT) as needed. Tapping machines for installing these taps should be equipped with high-speed, spiral flute, carbide-tipped drill bits.

Strap Type Taps

One style of small threaded tap for making service connections ranging from 3/4 inch to 2 inches in diameter is the strap type saddle. These strap type assemblies are carried in stock for lined cylinder pipe and bar-wrapped cylinder pipe and can be quickly fabricated for all sizes of concrete pressure pipe. The tap consists of a saddle with bolt-on steel straps, rubber gaskets, a gland, and a corporation stop.

Making a threaded tap on pressurized concrete pipe is relatively easy. The procedure involves chipping away the mortar coating on the pipe's exterior where the tap will be made, installing the saddle before cutting and removing the exposed prestressing wire or bar reinforcement, attaching the gland and corporation stop, testing the gland seal, and then tapping the steel cylinder and concrete or mortar core.

After the tap is completed, the whole tapping saddle assembly is encased in a portland cement concrete or mortar mix for corrosion protection. The taps can be easily encased using a cloth grout band around the exterior of the pipe, encircling the straps and then filling the grout band with grout.

STRAP TAP

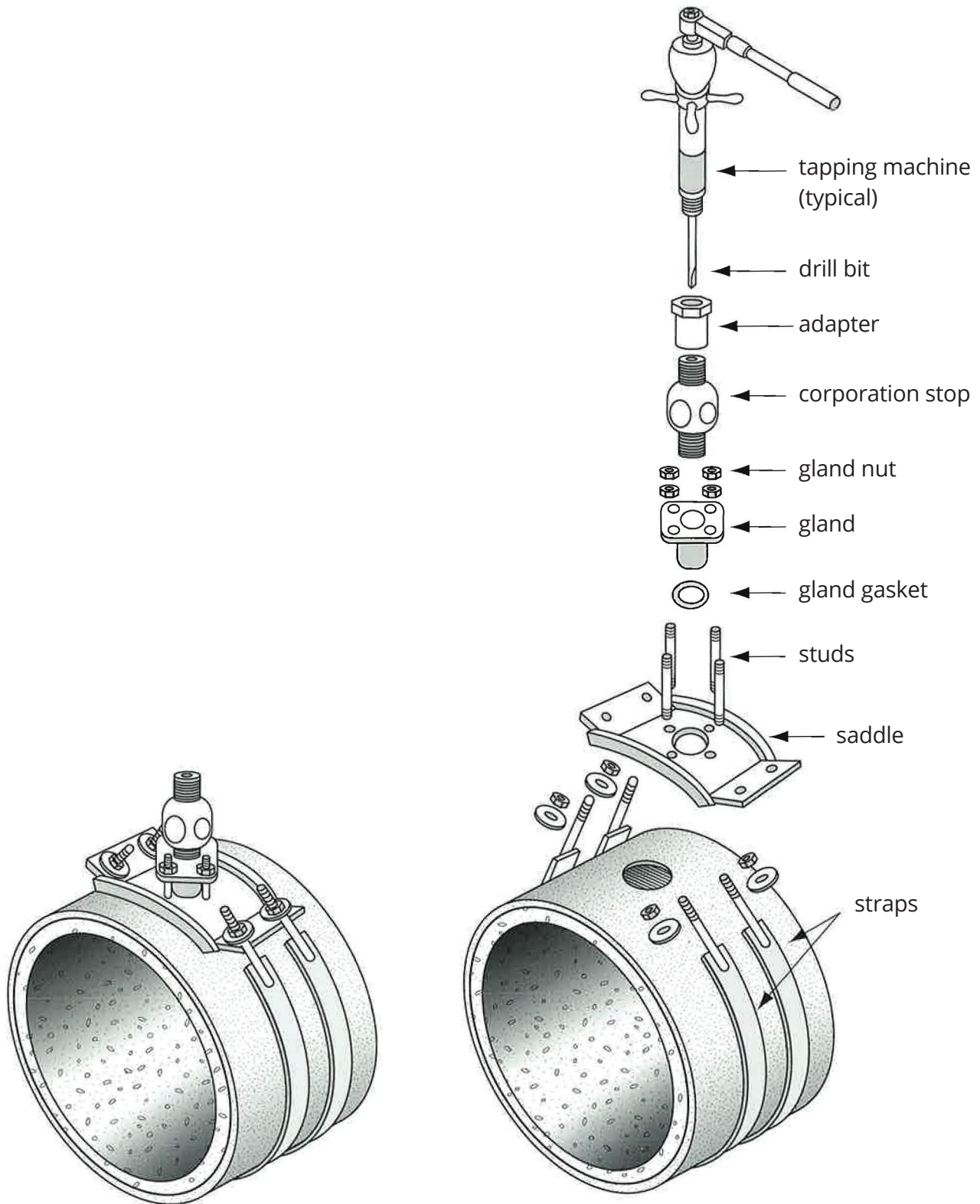

After the tap is installed, all metal parts must be encased in a 1:3 concrete or mortar mix with a minimum cover of 1 inch.

FLANGED PRESSURE TAPS

Flanged tapping sleeve assemblies with outlets 3 inches in diameter and larger can be supplied, which include the tapping saddle, steel bands, rubber gaskets, and a separate flanged tapping gland. Carbide tipped shell cutters and pilot drills, and power-operated tapping machines are recommended for making large taps in concrete pressure pipe. Tapping gate valves for large diameter taps are available from most valve manufacturers and can be obtained through Thompson Pipe Group. When specifying tapping valves larger than 12 inches, it is important to compare the inside port diameter of the valve with the outside diameter of the intended tapping machine shell cutter.

As is the case with smaller taps, the flanged outlet tap requires chipping away the mortar coating in the area in which the tap is to be made, attaching the tapping sleeve, then cutting the prestressing wires or reinforcing bar, installing the gland and tapping valve, testing the gland seal, bolting on the tapping machine, making sure it is properly supported, and then proceeding with the tap. When the tap is completed and the valve closed, the entire tap assembly should be encased in portland cement concrete or grout for corrosion protection.

On lined cylinder prestressed pipe, flanged outlet taps can be made for branch lines which have diameters as large as one size smaller than the diameter of the concrete pressure pipe to be tapped. Taps on embedded cylinder prestressed pipe should be restricted to diameters two sizes smaller than the pipe to be tapped. Thompson Pipe Group does not advocate the use of taps that are accomplished by welding the gland to the steel cylinder.

For further information on tapping concrete pressure pipe, consult the current AWWA M9 Manual. For specific concerns, recommendations, or assistance that you may require to make your tap a successful one, contact Thompson Pipe Group.

Lined Cylinder Pipe		Embedded Cylinder Pipe	
Pipe Diameter (inches)	Maximum Tap Diameter (inches)	Pipe Diameter (inches)	Maximum Tap Diameter (inches)
16	12	36	24
18	14	42	30
20	16	48	36
24	20	54-144	*
30	24		
36	30		
42	36		
48	42		

*two sizes smaller than nominal pipe diameter

LARGE DIAMETER TAP

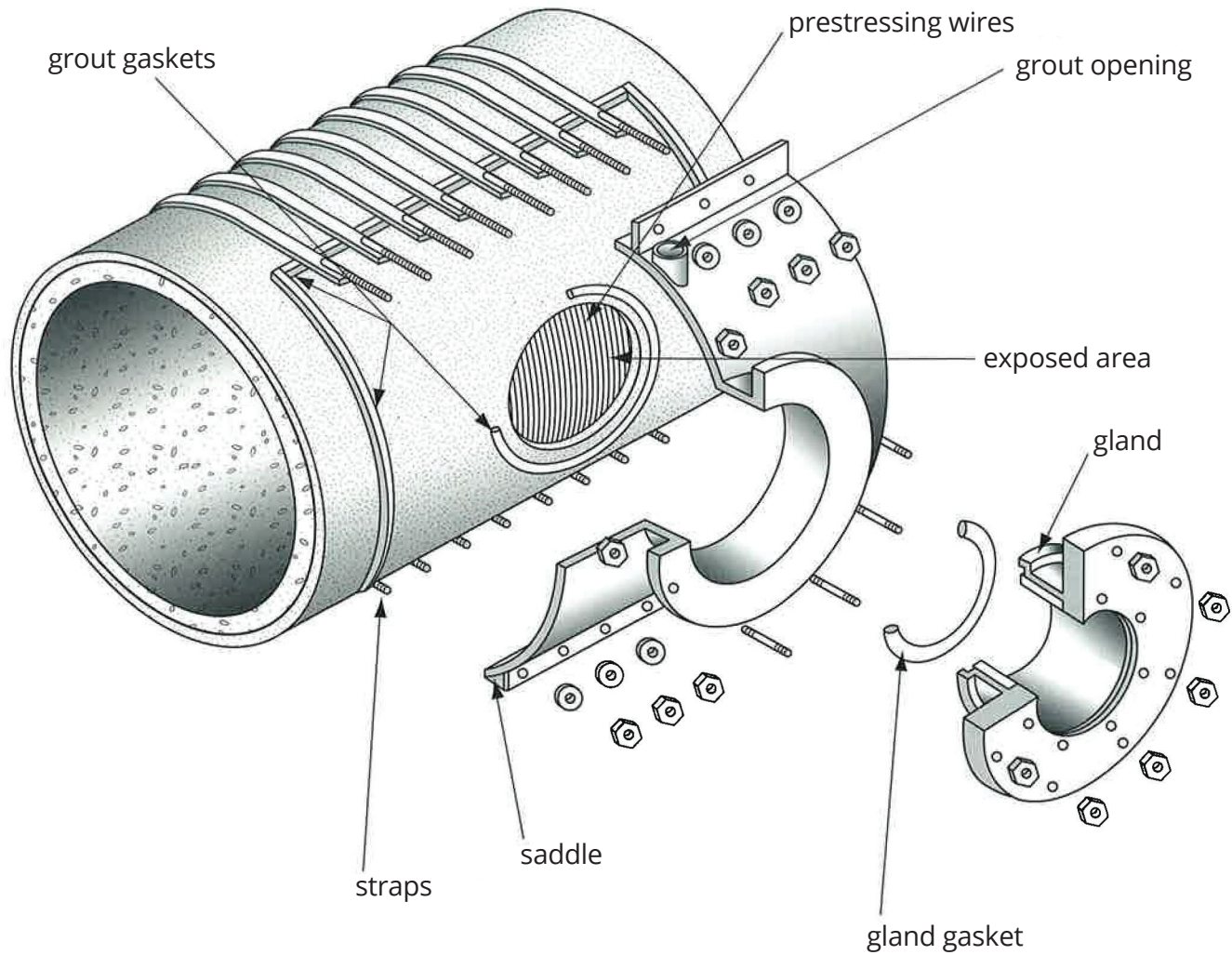

After the tap is installed, all metal parts must be encased in a 1:3 concrete or mortar mix with a minimum cover of 1 inch.



PIPELINE ENVIRONMENT

The environment in which a pipeline is installed can affect its long-term performance. The principal considerations are:

- soil types
- moisture and free oxygen levels
- pipeline materials

Prestressed concrete cylinder pipe and bar-wrapped concrete cylinder pipe have built in corrosion protection features which are all that is required in most environments. This section provides details of the above considerations and outlines procedures to prevent corrosion in those infrequent instances where adverse environments are suspected or encountered.

SOIL TYPES

The soils of the United States are generally divided into two major classes, with the dividing line falling close to 100 degrees west longitude (100th meridian). The average rainfall is roughly less than 25 inches per year west of that line and greater than 25 inches per year east of that line.

The soils in the eastern half of the country are referred to as pedalfers or humid region soils, whereas in the western half they are called pedocals or arid and sub-arid soils (see Figure 16-1). There are distinct differences between the two environments and these differences have a direct effect on buried structures.

PEDALFER SOILS

A pedalfers soil is one in which iron oxides or clays or both have accumulated in the B-horizon of the soil profile. The B-horizon is the subsoil immediately below the topsoil. In general, soluble materials such as calcium carbonate or magnesium carbonate do not occur in the pedalfers (see Figure 17-2).

Pedalfers are commonly found in temperate, humid climates, usually beneath forest vegetation.

In the formation of pedalfers, certain soluble compounds, particularly those that contain sodium, calcium, and magnesium are rapidly removed from the A-horizon by waters seeping into the soil from the surface.

These soluble compounds proceed downward through the B-horizon and are carried off by ground water. The less soluble iron oxides and clay are deposited in the B-horizon giving that zone a clay like character with a brownish to reddish color.

The pedalfers of the eastern United States tend to be slightly acidic and are less corrosive than the pedocals because most of the aggressive anions like chloride have been washed out of the pedalfers due to high rainfall. Precipitation in this soil region is in the range of 25 to 40 inches or more per year.

PEDOCAL SOILS

Pedocals are soils that contain an accumulation of calcium carbonate, and they tend to be alkaline. The soils of this major group are found in zones where the temperature and evaporation are relatively high, rainfall is low, and the vegetation is mostly grass or brush growth.

In the formation of pedocals, calcium carbonate and to a lesser extent, magnesium carbonate, are deposited in the soil profile, particularly in the B-horizon. This process occurs in areas where temperature is high, rainfall is scant, and the upper level of the soil is hot and dry most of the time.

Water evaporates before it can remove carbonates from the soil. The occasional rain may carry the soluble material down from the A-horizon into the B-horizon where it is later precipitated as the water evaporates. Soluble material may also move up into the soil from below. In this case, water beneath the surface or in its lower portion rises toward the surface through small capillary openings.

Then, as the water in the upper portion evaporates, the dissolved materials are precipitated. The low rainfall and high evaporation bring on alternate wetting and drying which results in high concentrations of soluble materials at pipe depths due to repetitive evaporation. This high concentration of solubles increases the soil's aggressiveness against ferrous metals. Precipitation in this region is generally less than 25 inches per year.

MAJOR SOIL CLASSES OF THE UNITED STATES

Figure 16-1

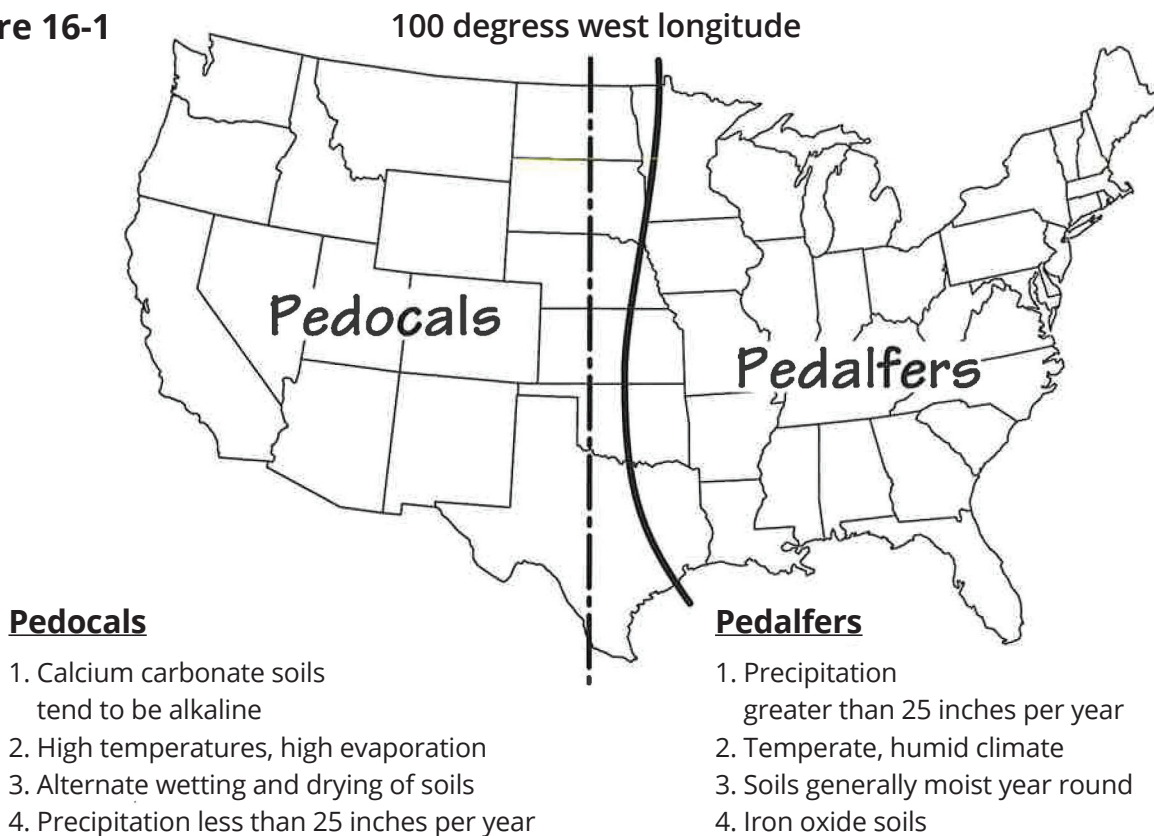

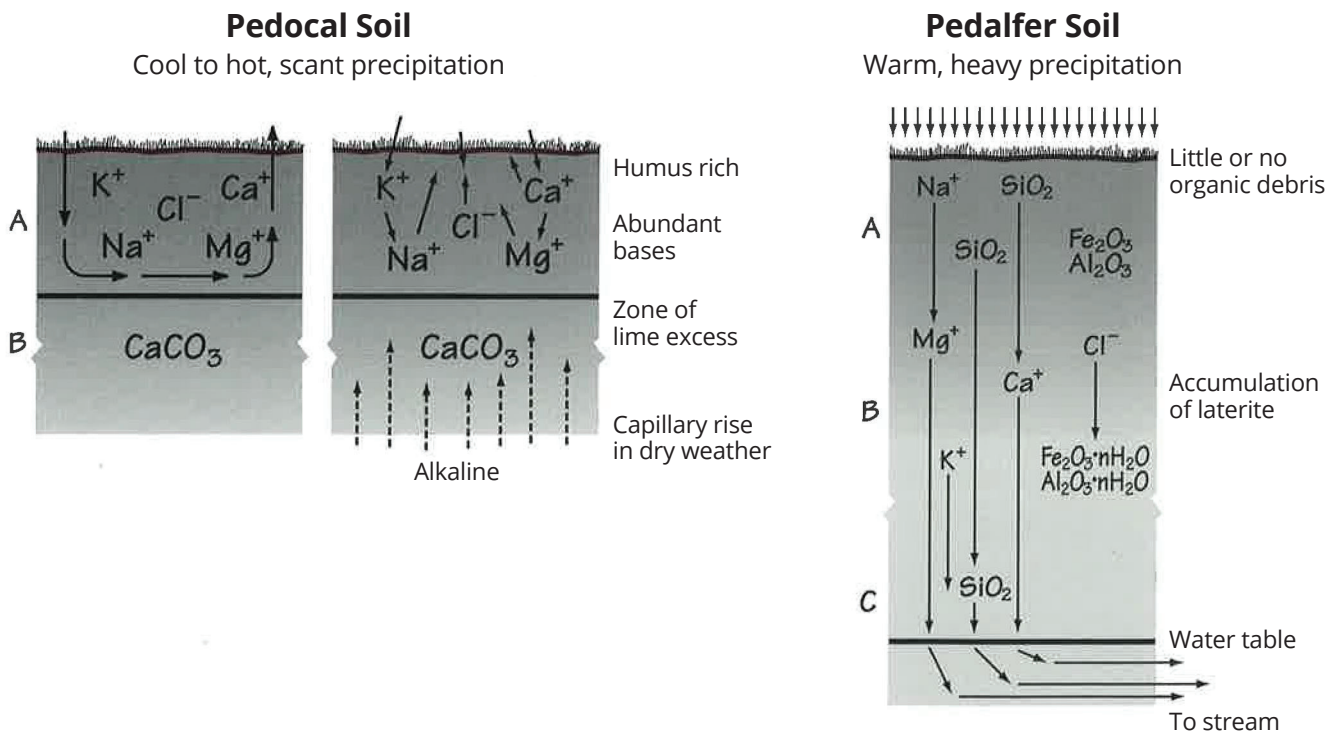

MOISTURE AND FREE OXYGEN LEVELS

In general, buried pipelines east of the 100th meridian are always below the moisture table as shown in Figure 16-3.

The moisture table is defined as a level below which the soil is constantly moist. A more technical definition for moisture table is the level of rise of moisture, by capillary action, from the water table. The distance "d" shown in Figure 16-3 is a function of soil type, air temperature, and amount of precipitation. In most eastern soils and climate conditions, the moisture table is very close to the surface.

If the water table fluctuates up or down, the moisture table will also fluctuate after a delay of some period of time.

For most eastern pipelines, with burial at 5 to 6 feet or more, the pipe is always below the moisture table, even considering the maximum fluctuations. Therefore, pipelines in the East are usually in a constant wet or moist environment and corrosion potential is low for concrete pipe.

In the arid conditions of the western U.S., one of three conditions can exist (see Figure 16-4). The first is where the pipe is significantly above the moisture table and the pipe is in a dry environment. Corrosion potential is relatively low. The second is where the pipe is just above the moisture table and the bottom of the pipe becomes alternatively wet and dry. There is increased potential for corrosion over the previous condition. In the third case, the pipe is partially above, and partially below, the moisture table. The area at the moisture table is subject to the most severe wetting and drying action.

MOISTURE CONDITIONS

Figure 16-3
Moisture Conditions
East of 100th Meridian

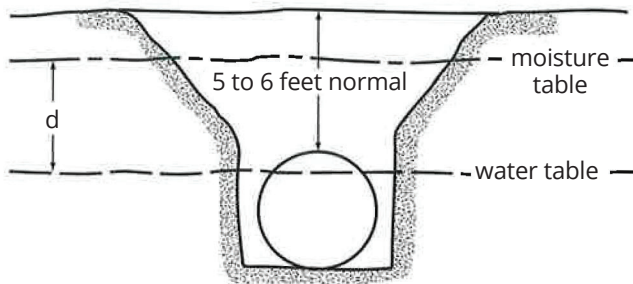
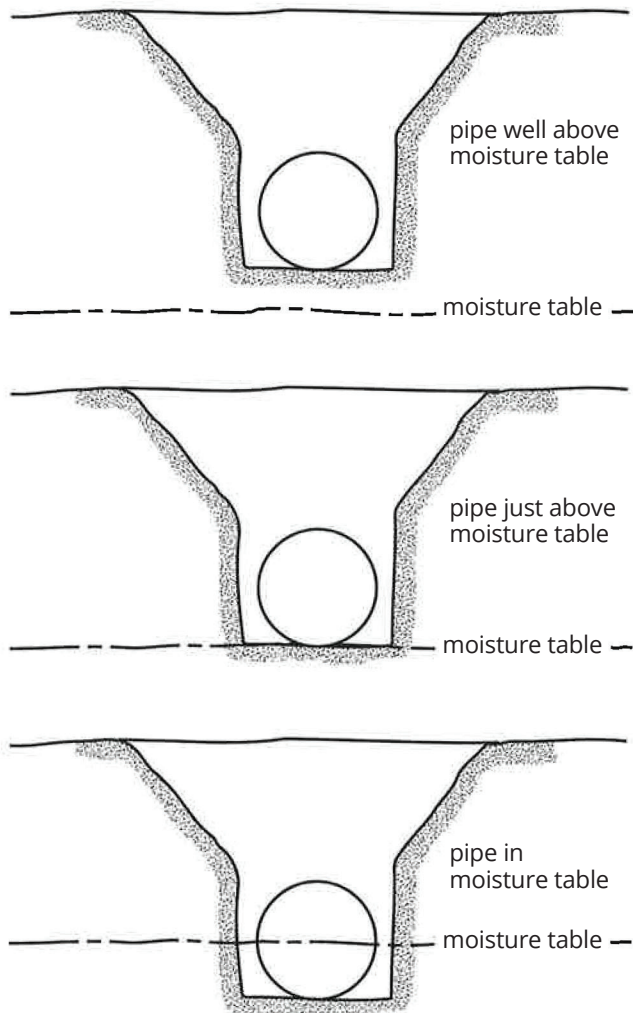

Figure 16-4
Moisture Conditions
West of 100th Meridian



PIPELINE MATERIALS

Understanding how corrosion takes place on a bare or organically coated ferrous pipe is relatively simple compared to understanding the corrosion protection provided to steel that has been encased in portland cement mortar or concrete.

Mortar protects steel by two synergistic mechanisms: as a barrier coat and by passivation through electrochemical reactions. For oxygen controlled corrosion to initiate on embedded steel components in concrete pressure pipe that has not been physically damaged or chemically altered, three concurrent factors are required. These are: 1) a chloride ion concentration greater than the corrosion threshold level of 400 parts per million at the steel-mortar interface; 2) moisture at the steel-mortar interface; 3) intrusion of atmospheric, free oxygen into the mortar coating very near to the steel.

It is extremely rare for these three factors to occur simultaneously in a buried pipeline. Even when they do, minimal corrosion is experienced unless there is a rapid resupply of free oxygen.

The mortar coating is the key to the superior protection against corrosion of steel in prestressed concrete cylinder pipe and bar-wrapped concrete cylinder pipe. Tests have shown that when an alkaline environment is maintained at the steel surface and free oxygen is excluded, corrosion of the steel can be prevented even in a high chloride environment. There are, however, environmental conditions that can directly attack or chemically alter the mortar coating. Supplemental precautions in certain instances may be needed.

PROTECTION OF CONCRETE CYLINDER PIPE IN ADVERSE ENVIRONMENTS

In most installation environments, no supplemental protection is required for prestressed concrete cylinder pipe or bar-wrapped concrete cylinder pipe. Adverse environments where precautionary measures should be taken to ensure pipeline integrity are:

- High chloride environments and stray current interference which may cause steel corrosion
- High sulfate or severe acid conditions or aggressive carbon dioxide in the soil or ground water which may alter the chemical protection provided by the mortar coating
- Long-term atmospheric exposure where carbonation or freeze/thaw cycles may affect the protection provided by the mortar coating.

HIGH CHLORIDE SOILS

Chloride ions in sufficient concentration can destroy the passivation of steel embedded in concrete and cause corrosion. For this to occur, oxygen must also be present at the steel surface.

In continuously submerged pipelines, the embedded steel in prestressed concrete cylinder pipe does not experience damaging corrosion because of the extremely slow rate of oxygen diffusion through the saturated mortar coating. This is true even in sea water which contains approximately 20,000 parts per million chloride ion concentration.

Although the mortar coating of continuously submerged lines does not require supplemental protection, a protective barrier coating is required for the joint rings if they cannot be grouted. In high chloride soils, cyclical wetting and drying in the pipe zone may result in high chloride concentrations and a supply of free oxygen in the mortar coating and eventually at the steel surfaces. This is most likely to occur in arid or semi-arid regions. In these circumstances when cyclical wetting and drying will occur in the pipe zone, if the chloride concentration exceeds 150 ppm, the exterior mortar surfaces should be protected with a barrier membrane, barrier coating, or sealer, or all pipe joints should be bonded and the line periodically monitored to check for corrosion. Where the pipe is buried in soil that seldom dries in the pipe zone, the barrier membrane, barrier coating, or sealer, or bonded joints should be used if the chloride concentration in the soil exceeds 1000 parts per million (ppm) and the resistivity is less than 1500 ohm-cm.

STRAY CURRENT INTERFERENCE

Buried metallic pipelines may collect and discharge stray currents which originate from nearby cathodically protected pipelines, electric railways, and other sources of direct current. The discharge of interference currents from organically coated steel pipelines occurs at pinholes or other flaws in the coating and results in pitting at these locations.

The effects of current discharge are quite different for steel encased in concrete or cement mortar. In prestressed concrete cylinder pipelines or bar-wrapped concrete cylinder pipelines, current discharge occurs over large surface areas rather than at pin holes and is opposed by polarization effects.

Because of these unique mitigating factors, concrete cylinder pipelines can tolerate stray current interference which would damage organically coated steel pipe. Nevertheless, when interference is present or anticipated, it is required that current discharge from concrete pressure pipelines be avoided or controlled. One or more of the following provisions may be appropriate:

- Eliminate or reduce to a safe level the source of interference.
- Apply a barrier membrane or barrier coating to the pipe.
- Bond pipe joints and monitor. If stray current discharge is detected, drain off the interfering current by connecting sacrificial anodes to the concrete pipe so the current discharges through the sacrificial anodes or, when properly analyzed and designed by qualified personnel, by connecting the concrete pipe to the source of the current.

HIGH SULFATE SOILS

Soils containing high concentrations of sodium, magnesium, and calcium sulfate are designated sulfate, or alkali soils. These soils can chemically attack concrete structures, particularly those partially buried in the soil where capillary action may build up high sulfate concentrations at ground level over time.

Completely buried concrete structures, including underground concrete pipelines, are not subject to this build-up and rarely suffer sulfate attack. Additionally, the high pPortland cement content of mortar coatings on concrete pressure pipe (approximately 950 pounds of cement per cubic yard) has been shown to greatly increase sulfate resistance.

For pipe installed in soil containing more than 2000 ppm of water-soluble sulfate ion or in groundwater containing more than 2000 ppm of sulfate ion, it is recommended that the tricalcium aluminate content in the cement not exceed 5 percent. In lieu of the special cement, a barrier coating, barrier membrane, or sealer may be applied to the pipe exterior to shield the mortar coating from sulfates in the environment. For pipe submerged in sea water or buried in soils with less than 2000 ppm of sulfates, standard Type 2 portland cement is recommended.

HIGH ACID SOILS

Cases of chemical attack upon concrete pipe in acidic soils are extremely rare and for the most part are limited to man-made conditions such as mine wastes and industrial dumps.

In clay soils, supplemental precautions against acid attack generally are not needed. In granular soils having a pH of 5 or greater, supplemental precautions against acid attack are rarely needed. Where the pH is less than 5 in granular soils and the total acidity exceeds 25 milliequivalents (meq) per 100 grams of dry soil, one of the following alternatives should be selected.

- Apply a barrier membrane or barrier coating to the pipe exterior.
- Surround the pipe with a compacted and relatively impermeable backfill material such as clay.
- Surround the pipe with a calcareous backfill material.

For all soils, where the soil pH is less than 4, a barrier membrane or barrier coating should be applied to the pipe exterior or the pipe should be installed in an envelope of non aggressive, consolidated clay.

AGGRESSIVE CARBON DIOXIDE

Carbonation is the reaction between calcium hydroxide or other hydration products in mortar or concrete and environmental carbon dioxide to produce calcium carbonate.

Surface carbonation which occurs during above ground storage is not detrimental to concrete pipe. Carbonation sufficient to damage buried concrete pipe is very unusual. High levels of carbon dioxide alone are not necessarily detrimental.

Other aspects of the soil and groundwater such as carbonate, calcium, and bicarbonate content and low soil permeability offset the effects of relatively large amounts of carbon dioxide. Conditions which could lead to damaging carbonation are rare and include carbon dioxide generation in the soil from sources such as decaying vegetation or geothermal activity, relatively soft groundwater, and highly permeable soil.

Unless there is a history of carbonation damage to buried concrete structures in the vicinity of a proposed concrete pipeline, there is no need to provide supplemental protection. When history or current soils and groundwater analyses indicate a potential problem, either a clay backfill should encase the pipe, a barrier membrane should be placed around the pipe, or the pipe exterior should be treated with a sealer.

LONG-TERM ATMOSPHERIC EXPOSURE

Experience has shown that cement mortar coatings on underground concrete pressure pipelines have a large reserve of alkalinity which prevents steel corrosion. However; the mortar coatings on pipe installed above ground may be subject to large temperature fluctuations, wetting and drying, freezing and thawing, and atmospheric carbonation which, over a period of many years, can detrimentally affect the protective properties of the coating. To protect such pipe, a light-colored barrier coating should be applied to the pipe exterior and renewed periodically to maintain its integrity. Joint rings should be protected with cement grout or with a light-colored barrier coating (see Section 17).

TYPICAL GALVANIC SERIES

Figure 16-5

METAL	VOLTS (Cu-CuSO4 Reference Electrode)
Commercially Pure Magnesium	-1.75
Magnesium Alloy (6% AL, 3% Zn, 0.15% Mn)	-1.60
Zinc	-1.10
Aluminum Alloy (5% Zinc)	-1.05
Commercially Pure Aluminum	- 0.80
Mild Steel (Clean and Shiny)	- 0.50 to - 0.80
Mild Steel (Rusted)	- 0.20 to -0.50
Cast Iron (Not Graphitized)	- 0.50
Lead	-0.50
Mild Steel In Concrete	- 0.20
Copper, Brass, Bronze	-0.20
High Silicon Cast Iron	-0.20
Carbon, Graphite, Coke	+0.30

CONNECTIONS TO OTHER PIPELINES

If concrete-encased steel such as a prestressed concrete cylinder pipe or bar-wrapped concrete cylinder pipe is connected to bare or organically coated metal, such as ductile iron or steel pipe, a difference in potential immediately develops. This occurs because the potential of steel encased in concrete normally lies between 0 and -300 millivolts to a copper-copper sulfate reference electrode (CSE) which is approximately 300 millivolts more noble than the potential of bare steel (see Figure 17-5). Therefore, if an uninsulated connection is made between a concrete pressure pipeline and a bare or organically coated ferrous pipeline, the concrete pressure pipe will not be affected, whereas the steel pipeline may sacrificially corrode.

This situation is tempered by the polarization of the concrete-encased steel which occurs over a period of time during which the potential of the steel encased in concrete will shift toward that of the bare or organically coated ferrous pipe. As the concrete pipe potential approaches that of the ferrous pipe, the current flow between the two will approach zero. The corrosion rate of the ferrous pipe will be reduced and the concrete-encased steel will not be affected.

The best way to prevent this type of corrosion of buried ferrous pipe is to encase it in concrete during installation or to electrically insulate the connections between the two dissimilar piping materials.

BONDING, MONITORING, AND CATHODIC PROTECTION

Electrically bonding and monitoring of concrete pressure pipelines should be considered when the pipeline is installed in a known adverse environment (see High Chloride Soils and Stray Current Interference), and long-term surveillance of the pipeline is desired.

If the pipeline is to be bonded and monitored, all steel elements in each pipe section should be electrically connected at the time of manufacture, and the entire pipeline should be made electrically continuous by connecting pipe joints with low resistance bonds at the time of installation (see Section 4 – Bonded Joints).

The monitoring program begins by establishing base line potentials after installation. A second survey should be made approximately one year thereafter. Time intervals between subsequent surveys of testing should be established after evaluating the results of prior surveys.

Concrete pressure pipeline potentials more negative than -300 millivolts (CSE) may require further investigation.

Frequently, such readings are due to corrosion of iron or steel pipelines or other steel structures attached to the concrete pipeline. This is referred to as polarization and it may be necessary to insulate the ferrous pipeline from the concrete line.

CATHODIC PROTECTION

Cathodic protection of ferrous pipelines, such as steel or ductile iron, is frequently applied because these materials begin to corrode immediately after installation. Cathodic protection of concrete pressure pipe is rarely required because the steel components are protected from corrosion by a mortar coating rich with portland cement.

In those infrequent instances when monitoring and pipeline investigation indicates corrosion of steel elements, remedial measures should be taken. Repair of the pipe is of first importance to reestablish the pipe's structural integrity. Once the line is repaired, it may be beneficial to apply cathodic protection to the affected section of the pipeline to prevent future corrosion.

Cathodic protection may also be used to prevent further damage on the pipeline where corrosion has not progressed to the state where repair is necessary.

At least one researcher has demonstrated that corrosion of steel in concrete can be arrested at a current potential of -710 millivolts (CSE). If bare steel is exposed to the soil environment, the potential should be lowered to -850 millivolts (CSE). The potential should never be permitted to exceed -1000 millivolts (CSE) to avoid hydrogen evolution.

In the rare instances where cathodic protection of concrete pressure pipe is needed, the sacrificial anode type of system should be considered over the impressed current system. The sacrificial system is less likely to cause stray current interference on other structures, is less likely to evolve hydrogen, and requires less frequent monitoring, maintenance, and adjustment.

The design of a cathodic protection or pipeline monitoring system for any pipeline, regardless of pipe material, requires the services of a competent and experienced corrosion engineer.

SUMMARY OF GUIDELINES FOR EXTERNAL PROTECTION OF CONCRETE CYLINDER PIPE IN ADVERSE ENVIRONMENTS

Condition	Criteria	Protection
High chloride soils	Pipe buried in soil rarely dry in the pipe zone, containing a water soluble chloride content exceeding 1000 ppm, and with resistivity less than 1500 ohm-cm.	B, D or C, G or C, N or C, O
	Pipe buried in soils subject to cyclical wetting and substantial drying in the pipe zone, containing a chloride content exceeding 150 ppm.	B, D or C, G or C, N or C, O
High sulfate soils	Soil containing more than 2000 ppm of water-soluble sulfate ion or groundwater containing more than 2000 ppm of sulfate ion.	B, F or C, N or C, G or C, O
High acid soils	Granular soil with pH less than 5 and total acidity greater than 25 meq per 100 grams of dry soil.	B, K or B, L or C, G or C, N
	Any soil with pH less than 4.	C, G or B, K or C, N
Aggressive carbon dioxide	History of carbonation damage to buried concrete structures.	B, K or C, G or C, O
	Highly permeable soils with decaying vegetation or geothermal activity and soft groundwater.	
Stray current interference	Prolonged discharge of direct current picked up from cathodic protection systems or other DC source.	B, D, M or B, E or C, D, G or C, D, N
Connections to other pipelines	Connection to organically coated or cathodically protected pipelines.	J
Long-term atmospheric exposure	Continuous exposure to salt water spray in coastal zones.	C, H or H, I
	Other continuous atmospheric exposure.	A, H or H, I

Supplemental Protection

A = Grout the exterior joint recess with cement mortar when expansion joints are provided.

B = Grout the exterior joint recess with cement mortar.

C = Grout the exterior joint recess with cement mortar using an impermeable grout band.

D = Provide a steel shorting strap under the prestressing wire or reinforcing bar; electrically connect all steel components in the pipe. Make pipeline joints electrically continuous with low resistance bonds; provide test stations to monitor pipe potentials and current flow.

E = Remove direct current (DC) source.

F = Use portland cement containing not more than 5 percent tricalcium aluminate for cement mortar coatings.

G = Apply a barrier membrane to pipe exterior.

H = Apply a light-colored barrier coating to the pipe exterior; recoat as necessary to maintain coating integrity.

I = Apply a light-colored barrier coating to protect the steel joint rings.

J = Electrically insulate the connecting pipelines.

K = Surround the pipe with compacted and relatively impermeable backfill.

L = Surround the pipe with calcareous backfill material.

M = Monitor and, if needed, drain off stray current.

N = Apply a barrier coating to the pipe exterior.

O = Apply a sealer to the pipe exterior.



SUPPLEMENTAL PROTECTION FOR CONCRETE PRESSURE PIPE

Although concrete pressure pipe rarely requires supplemental protection, Section 16 details certain aggressive soil and environmental conditions which can affect the long-term performance of concrete pressure pipe. Section 16 also provides precautionary measures to take in the infrequent situations when these adverse conditions are encountered.

This section provides information concerning the various protective barrier coatings, sealers, and barrier membranes that can be used on concrete pressure pipe. This information is arranged such that it can be directly incorporated into your present specifications as needed.

EXTERIOR BARRIER COATING FOR ABOVE-GROUND PIPE INSTALLATIONS

The mortar coating of pipe and exterior mortar coating of fittings shall be painted with two coats of a white epoxy paint.

The epoxy can be applied by brush, roller, or spray system using equipment recommended by the manufacturer of the epoxy.

The surfaces to be painted shall be clean and dry. The temperature shall be in accordance with the paint supplier's recommendations. During application and curing, the temperature will be maintained per the paint supplier's recommendation. Mortar coating surfaces need not be sandblasted.

Steel surfaces to be painted should be sandblasted, solvent cleaned, or wire brushed. Time between coats shall be as recommended by the manufacturer of the epoxy and the total dry film thickness shall be a minimum of 16 mils. Vertical surfaces at the exterior bell and spigot shoulders do not require painting if the exterior joint space will be grouted in the field and the same white epoxy paint applied over the cured grout.

When the exterior joint space will not be grouted in the field, or when required, the pipe supplier shall paint the vertical concrete or mortar surfaces of the outside of the pipe and those portions of the steel joint rings which are outside the gasket seal. The total dry film thickness of the paint on the sealing surfaces of the steel joint rings should not exceed 8 mils.

EXTERIOR BARRIER COATING FOR AGGRESSIVE SOILS

The exterior mortar coating of pipe and fittings in the areas as described on the plans shall be painted with one coat of a high-build, coal tar epoxy or two coats of a standard coal tar epoxy.

Pipe made and stored during a hot environment as defined in AWWA C304 design standard for prestressed concrete pressure pipe which is to be painted externally with a coal tar epoxy, must be painted with a white epoxy instead of a coal tar epoxy.

The epoxy can be applied by brush, roller, or spray system using equipment recommended by the manufacturer of the epoxy.

The surfaces to be painted shall be clean and dry and the temperature shall be within the limits recommended by the manufacturer of the epoxy. Mortar coating surfaces need not be sandblasted.

Concrete or steel surfaces to be painted should be sandblasted, solvent cleaned, or wire brushed. Time between coats (if applicable) shall be as recommended by the manufacturer of the epoxy paint. The vertical surfaces at the bell and spigot shoulders do not require painting if the exterior joint space will be grouted in the field and a special grout band with a dielectric lining is used.

EXTERIOR BARRIER MEMBRANE FOR AGGRESSIVE SOILS

In the areas described on the plans or in the specifications, all concrete pressure pipe shall be encased in a high-density, cross-laminated polyethylene tube of 6.5 mil.

INTERNAL LINING PROTECTION

When supplemental protection is needed for an aggressive sewer environment, several options exist. The interior of the PCCP can be lined with a PVC liner or an antimicrobial admixture can be added to the core concrete.



LAYOUT

The Thompson Pipe Group Engineering Department provides a laying schedule and associated documents to the installing contractor.

This schedule is a sequential list of the pipe and fittings required to meet the installation requirements shown on the project plans. Stationing and elevations of coded fittings and specials are shown to serve as a guide to the installer.

A list of standard abbreviations generally used in the laying schedules and on drawings can be found in the Appendix, Section 21.

In addition to the above mentioned documents, pipe design sheets and detail drawings are developed as needed. Details of special pipe or fittings are contained on detail drawings. The design sheet contains various pipe parameters and loads considered in the design. An example of a design sheet is shown on page 18.4 and an example of a detail drawing is shown on page 18.5. These documents are also made available to the installing contractor or engineer as needed.

TITLE PAGE



PROJECT: 190075
DESCRIPTION: REDBUD PUMP STATION
 42" TRANSMISSION WATER LINE (850PP) – PHASE 2
LOCATION: MCKINNEY, TEXAS
OWNER: CITY OF MCKINNEY
ENGINEER: BGE, INC.
 D. BRYANT CASWELL
 972-464-4812
CONTRACTOR: EXCEL TRENCHING
 DERRICK GAGE
 210-823-6778

PIPE SUMMARY

DESCRIPTION	LENGTH
42" B-303 CL 150-21-10Ga	4542'
42" B-303 CL 150-20-0.25	120'
TOTAL	4662'

THOMPSON PIPE GROUP CONTACTS FOR THIS PROJECT:
 ENGINEERING:
 SALES:
 DELIVERY:
 FIELD SERVICES:

CAUTION: BEFORE LIGHT CONSTRUCTION EQUIPMENT (TRACK HOES, FRONT END LOADERS, PICK-UP TRUCKS ETC) ARE PERMITTED TO CROSS OVER THE PIPE, ENSURE THERE IS AT LEAST THREE FEET OF COMPACTED BACKFILL OVER THE TOP OF THE PIPE. FOR HEAVIER CONSTRUCTION EQUIPMENT (LARGE CRANES, LOADED CONCRETE TRUCKS, SPECIALIZED DUMP TRUCKS ETC), THOMPSON PIPE GROUP SHOULD BE CONTACTED FOR CROSSING RECOMMENDATION.

CAD File: 190075G1.dwg, Title Model: Laminar Saved: 6/12/2020 7:40 AM

					RELEASED COPY ISSUED FOR FABRICATION JUN 12, 2020	REDBUD PUMP STATION 42" TRANSMISSION WATER LINE (850PP) – PHASE 2 MCKINNEY, TEXAS												
<table border="1"> <thead> <tr> <th>NO.</th> <th>REVISION</th> <th>DATE</th> <th>BY</th> <th>CHK</th> </tr> </thead> <tbody> <tr> <td> </td> <td> </td> <td> </td> <td> </td> <td> </td> </tr> </tbody> </table>						NO.	REVISION	DATE	BY	CHK						DRAWN: JMF 2/6/20	CHECKED:	QUOTE: 171129-876
NO.	REVISION	DATE	BY	CHK														

LAY DRAWING EXAMPLE

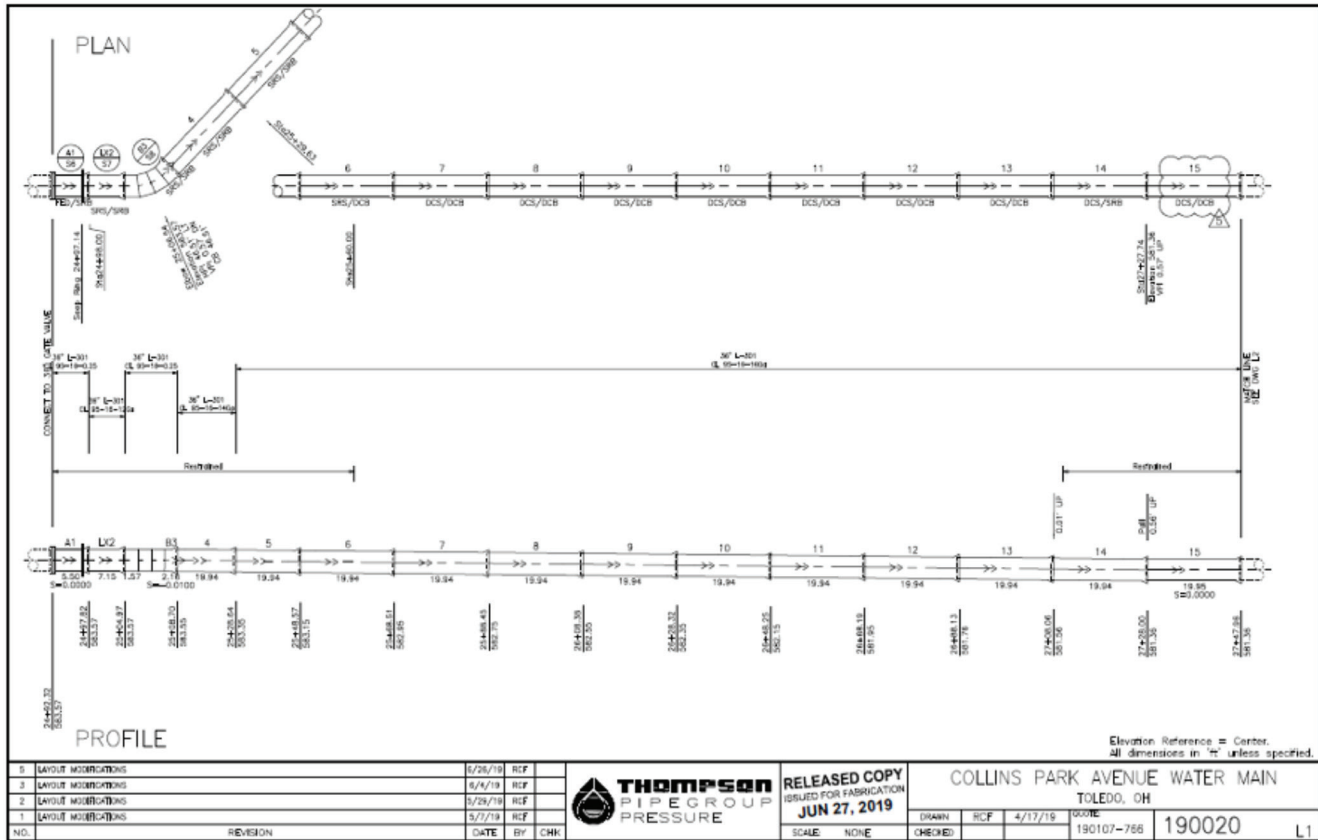

DESIGN SHEET EXAMPLES

B-303 BAR-WRAPPED CONCRETE CYLINDER PIPE

- NOTES:
 1. ALL DIMENSIONS ARE IN INCHES.
 2. SEE SHEET D1 FOR GENERAL NOTES, MATERIAL SPECIFICATIONS AND SHOP TESTING REQUIREMENTS.

LINING: C303 CEMENT MORTAR
 COATING: C303 CEMENT MORTAR

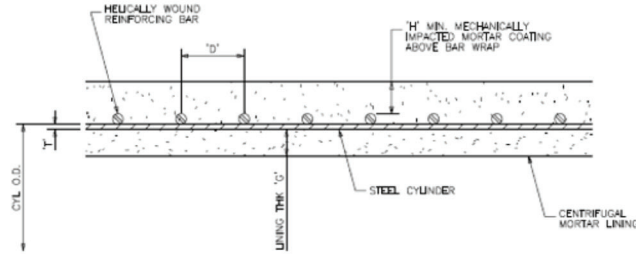

ROW	STEEL CYLINDER				SPIRALLY WOUND REINFORCEMENT							LINING THICK' (IN)	COATING THICK ABOVE BAR WRAP 'H' (IN)	APPROX HEIGHT (LBS/FT)			
	NOMINAL I.D. OF PIPE (IN)	DESIGN PRESSURE (PSI)	ALLOWABLE DEPTH OF COVER (FT)	TOTAL A _s PER LINEAR FT. (SQ.IN)	O.D. OF CYLINDER (IN)	GAUGE OR THICKNESS 'T'	A _s PER LINEAR FT. (SQ.IN)	CYL TEST PRESSURE (PSI)	CYLINDER HEIGHT (LBS/FT)	A _s PER LINEAR FT. (SQ.IN)	BAR DIA (IN)				COILS PER LINEAR FT	BAR SPACING 'D' (IN)	BAR WRAP (LBS/FT)
D3-A	16	150	10	1.01	17 3/8	16 Ga	0.72	188	11.1	0.29	1/4	5.91	2.03	4.5	5/8	3/4	124

H=20 LINE LOAD (OR TRUCK LINE LOAD) FOR EARTH COVER GREATER OR EQUAL TO 10FT. ARE INSUFFICIENT FOR THE AREA OR MANUAL FOR EARTH COVER LESS THAN 10FT. COMBINATION OF EARTH LOAD AND LINE LOAD IS LESS THAN MAXIMUM ALLOWABLE EXTERNAL LOAD THAT PIPE IS DESIGNED TO HANDLE

					RELEASED COPY ISSUED FOR FABRICATION JUL 26, 2019	CYPRESS WATERS WATER TRANSMISSION LINES						
						COPPELL, TEXAS						
NO.	REVISION	DATE	BY	CHK	SCALE: NONE	DRAWN: PRK	5/22/18	CHECKED: JMF	5/23/18	190104-760	190024	D3

L-301 LINED CYLINDER PRESTRESSED CONCRETE PIPE

- NOTES:
 1. ALL DIMENSIONS ARE IN INCHES.
 2. SEE SHEET D1 FOR GENERAL NOTES, MATERIAL SPECIFICATIONS AND SHOP TESTING REQUIREMENTS.

CORE: C301 CONCRETE
 COATING: C301 CEMENT MORTAR

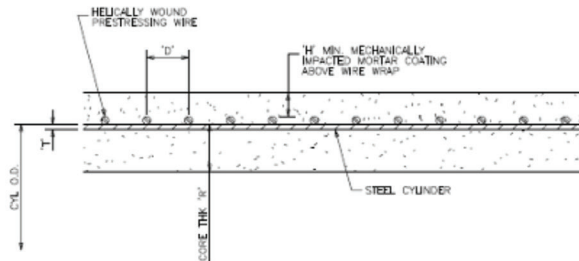

ROW	STEEL CYLINDER				HIGH TENSILE STEEL WIRE WRAP							CONCRETE CORE				COATING THICK ABOVE WIRE WRAP 'H' (IN)	APPROX HEIGHT (LBS/FT)			
	NOMINAL I.D. OF PIPE (IN)	DESIGN PRESSURE (PSI)	ALLOWABLE DEPTH OF COVER (FT)	SPUN OR CAST	O.D. OF CYLINDER (IN)	GAUGE OR THICKNESS 'T'	CYL TEST PRESSURE (PSI)	CYLINDER HEIGHT (LBS/FT)	A _s PER LINEAR FT. (SQ.IN)	WIRE DIA.	COILS PER LINEAR FT	WIRE SPACING 'D' (IN)	WIRE WRAP (LBS/FT)	WIRE GROSS STRESS (PSI)	ACTUAL PULL (LBS)			CORE THICK 'C' (IN)	RED'D STRENGTH @ 28 DAYS (PSI)	RED'D STRENGTH @ 90 DAYS (PSI)
D3-A	36	95	16	SPUN	40 1/2	12 Ga	104	45.1	0.282	#6-III	9.74	1.23	10.2	189000	5472	2 1/4	3000	5510	3/4	482
D3-B	36	95	16	SPUN	40 1/2	14 Ga	75	32.3	0.282	#6-III	9.74	1.23	10.2	189000	5472	2 1/4	3000	5510	3/4	473
D3-C	36	95	16	SPUN	40 1/2	16 Ga	60	25.8	0.282	#6-III	9.74	1.23	10.2	189000	5472	2 1/4	3000	5510	3/4	469

H=20 LINE LOAD (OR TRUCK LINE LOAD) FOR EARTH COVER GREATER OR EQUAL TO 10FT. ARE INSUFFICIENT FOR THE AREA OR MANUAL FOR EARTH COVER LESS THAN 10FT. COMBINATION OF EARTH LOAD AND LINE LOAD IS LESS THAN MAXIMUM ALLOWABLE EXTERNAL LOAD THAT PIPE IS DESIGNED TO HANDLE

					RELEASED COPY ISSUED FOR FABRICATION MAY 07, 2019	COLLINS PARK AVENUE WATER MAIN						
						TOLEDO, OH						
NO.	REVISION	DATE	BY	CHK	SCALE: NONE	DRAWN: RCF	4/17/19	CHECKED:		190107-766	190020	D3

E-301 EMBEDDED CYLINDER PRESTRESSED CONCRETE PIPE

- NOTES:
 1. ALL DIMENSIONS ARE IN INCHES.
 2. SEE SHEET D1 FOR GENERAL NOTES, MATERIAL SPECIFICATIONS AND SHOP TESTING REQUIREMENTS.
 COATING: C301 CEMENT MORTAR

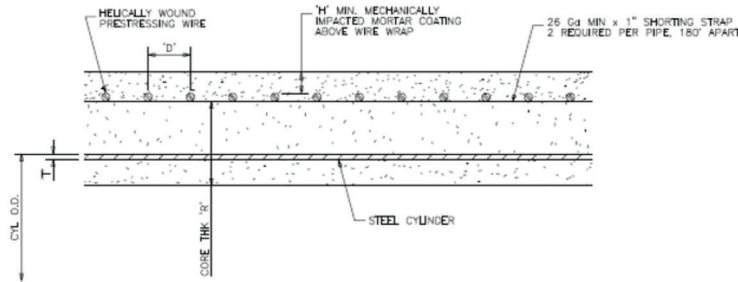

ROW	STEEL CYLINDER				HIGH TENSILE STEEL WIRE WRAP								CONCRETE CORE			COATING		APPROX W/HT (LBS/FT)	
	NOMINAL I.D. OF PIPE (IN)	DESIGN PRESSURE (PSI)	ALLOWABLE DEPTH OF COVER (FT)	O.D. OF CYLINDER (IN)	GAUGE OR THICKNESS T	CYL TEST PRESSURE (PSI)	CYLINDER W/HT (LBS/FT)	AS PER LINEAR FT. (SQ IN)	WIRE DIA.	COILS PER LINEAR FT.	WIRE SPACING "O" (IN)	WIRE WRAP (LBS/FT)	WIRE GROSS STRESS (PSI)	ACTUAL PULL (LBS)	CORE THICK (IN)	REQ'D STRENGTH @ WRAP (PSI)	REQ'D STRENGTH @ 28 DAYS (PSI)		COATING THICK ABOVE WIRE WRAP (IN)
D4-A	66	75	16	69 1/2	8 Ga	113	121.7	0.396	#6-III	13.68	0.88	26.9	189000	5472	5	3000	5500	3/4	1534
D4-B	66	75	13	69 1/2	12 Ga	70	77.5	0.326	#6-III	11.26	1.07	22.1	189000	5472	5	3000	5500	3/4	1500
D4-C	66	75	13	69 1/2	14 Ga	48	55.4	0.326	#6-III	11.26	1.07	22.1	189000	5472	5	3000	5500	3/4	1484
D4-D	66	75	13	69 1/2	10 Ga	92	99.6	0.326	#6-III	11.26	1.07	22.1	189000	5472	5	3000	5500	3/4	1515

HE-20 LIVE LOAD (OR TRUCK LIVE LOAD) FOR EARTH COVER GREATER OR EQUAL TO 10FT. ARE INSIGNIFICANT FOR THE ABOVE PIPE. FOR EARTH COVER LESS THAN 10FT. COMBINATION OF EARTH LOAD AND LIVE LOAD IS LESS THAN MAXIMUM ALLOWABLE EXTERNAL LOAD THAT PIPE IS DESIGNED TO HANDLE.

1 CONSOLIDATE DESIGNS	REVISION	DATE	BY	CHK		RELEASED COPY ISSUED FOR FABRICATION MAR 18, 2019	SABINE RIVER WATER SUPPLY PROJECT 66-INCH RAW WATER PIPELINE ORANGE, TX
NO.	REVISION	DATE	BY	CHK	SCALE	NONE	DRAWN: DW 10/19/18 CHECKED: 161128-117 180073 D4

DETAIL DRAWING EXAMPLE

HCS	RELBK	GRND	NOTES:	HCB	RELBK	GRND	ITEM No	QTY	DESCRIPTION	REF SHEET
INTERIOR	FLUSH		- ALL JOINTS ARE TO BE BONDED PER SHEET G10 UNLESS FIELD WELDED.	INTERIOR	4 1/2		1	1	69.500" OD x 0.375" x 8'-0" ROLLED PIPE	
EXTERIOR	6.5			EXTERIOR	3		2	1	HCS END WITH 3/4" x 3" x 74" OD TRANSITION BAR	D14-A
							3	1	HCB END WITH 3/4" x 3" x 74" OD TRANSITION BAR	D14-A

NO.	REVISION	DATE	BY	CHK		RELEASED COPY ISSUED FOR FABRICATION APR 19, 2019	SABINE RIVER WATER SUPPLY PROJECT 66-INCH RAW WATER PIPELINE ORANGE, TX	DRAWN: DW 10/19/18 CHECKED: 161128-117 180073 S128	Lining: C301 Cement Mortar, 1 3/8" Coating: C301 Cement Mortar, 1" Class: 75-28-0.375 Inflexion: 44.95° Radius: 165.00" SS Chord: 6'-9 1/8"	

SYMBOLS & ABBREVIATIONS

SYMBOLS

ABBREVIATIONS

ARV - AIR RELEASE VALVE	DCS - DEEP CARNEGIE SPIGOT	HCB - HARNESS CLAMP BELL	OD - OUTSIDE DIAMETER	STD - STANDARD
ATH - AIR TEST HOLE	DEG - DEGREE	HCBT - HARNESS CLAMP TESTABLE BELL	OL - OUTLET	STL - STEEL
AV - AIR VENT	DFT - DRY FILM THICKNESS	HCS - HARNESS CLAMP SPIGOT	OS - OFFSET	TAN - TANGENT
B-303 - AWWA C303 PIPE	DIA - DIAMETER	HCST - HARNESS CLAMP TESTABLE SPIGOT	PC - PIECE	THK - THICKNESS
BB - BANDED BELL	DIM - DIMENSION	HD - HEAD	PE - PLAIN END	TOL - THREADED OUTLET
BBV - BEVEL	DLWB - DEEP LAPWELD BELL	HDB - HEAVY DUTY HARNESS CLAMP BELL	PEBS - PLAIN END FOR BUTTSTRAP	TOT - TANGENTIAL OUTLET
BFV - BUTTERFLY VALVE	DLWT - DEEP LAPWELD BELL W/AIR TEST HOLE	HHS - HEAVY DUTY HARNESS CLAMP SPIGOT	PEBW - PLAIN END FOR BUTTWELDING	VERT - VERTICAL
BHC - BEGN HORIZ CURVE	DWS - DEEP LAPWELD SPIGOT	HRT - HORIZONTAL	PEDE - DEPEND-O-LOK COUPLING EXE	VPI - VERT POINT OF INTERSECT
BI - BID ITEM	DN - DOWN	IBPI - HORIZ POINT OF INTERSECT	PEDF - DEPEND-O-LOK COUPLING FWF	WCB - FW CARNEGIE BELL
BK - BACK	DWG - DRAWING	IN - INSIDE DIAMETER	PEFC - PLAIN END FOR FLEX COUPLING	WCBT - FW TESTABLE CARNEGIE BELL
BLD FLG - BLIND FLANGE	E-301 - EMBEDDED CYLINDER PIPE	INCHES - INCHES	BYT - QUANTITY	WCS - FW CARNEGIE SPIGOT
BO - BLOW OFF	EACH - EACH	INVERT - INVERT	REF - REFERENCE	WCSC - FW CARNEGIE SPIGOT w/GKT GROOVE REMOVED
BOP - BOTTOM OF PIPE	ECC - ECCENTRIC	L-301 - LINED CYLINDER PIPE	RGB - ROLLED GROOVE BELL	WCST - FW TESTABLE CARNEGIE SPIGOT
BVC - BEGN VERT CURVE	EHC - END HORIZ CURVE	LEN - LENGTH	RGS - ROLLED GROOVE SPIGOT	WCSTC - FW TESTABLE CARNEGIE SPIGOT w/GKT GROOVE REMOVED
C/L - CENTERLINE	ELEV - ELEVATION	LL - LAY LENGTH	ROT - RADIAL OUTLET	WDCB - FW DEEP CARNEGIE BELL
CB - COMBINED	EQU - EQUATION	LOT - LATERAL OUTLET	RT - RIGHT	WDCSC - FW DEEP CARNEGIE SPIGOT w/GKT GROOVE REMOVED
CB - CARNEGIE BELL	END - END VERT CURVE	LS - LUMP SUM	S-200 - AWWA C200 PIPE	WT - WEIGHT
CBT - TESTABLE CARNEGIE BELL	FE150 - FLANGED END - CLASS 150	LT - LEFT	SCH - SCHEDULE	WXCB - FW EXTRA DEEP CARNEGIE BELL
CL - CLASS	FED - FLANGED END - CLASS D	LWB - LAPWELD BELL	SHT - SHEET	WXCS - FW EXTRA DEEP CARNEGIE SPIGOT
CONC - CONCENTRIC	FEF - FLANGED END - CLASS E	LWBT - LAPWELD BELL W/AIR TEST HOLE	SRI - SNAP RING BELL	WXCSB - FW EXTRA DEEP CARNEGIE SPIGOT w/GKT GROOVE REMOVED
CPI - COMBINED POINT OF INTERSECT	FEF - FLANGED END - CLASS F	LWS - LAPWELD SPIGOT	SRB - SNAP RING BELL	XCB - EXTRA DEEP CARNEGIE BELL
CPUG - COUPLING	FOL - FLANGED OUTLET	LWST - LAPWELD SPIGOT W/AIR TEST HOLE	SRBT - SNAP RING TESTABLE BELL	XCS - EXTRA DEEP CARNEGIE SPIGOT
CS - CARNEGIE SPIGOT	FT - FIELD TOP	MAX - MAXIMUM	SRS - SNAP RING SPIGOT	w/o - WITHOUT
CST - TESTABLE CARNEGIE SPIGOT	FA - FITTING	MH - MANHOLE	SRST - SNAP RING TESTABLE SPIGOT	
CTE - COAL TAR EPOXY	FW - FIELD WELD	MN - MINIMUM	SS - STAINLESS STEEL	
CTF - CUT TO FIT	GKT - GASKET	NPT - NATIONAL PIPE THREAD	SS - SHORT SIDE	
CTF - FIELD CUT-TO-FIT END	GR - GRADE	No - NUMBER	STA - STATION	
CYL - CYLINDER	Ga - GAUGE	ODL - OVERALL LENGTH		
DCB - DEEP CARNEGIE BELL				

NO.	REVISION	DATE	BY	CHK

RELEASED COPY ISSUED FOR FABRICATION JUN 12, 2020	SCALE: NONE	DRAWN: JMF	CHECKED: JMF	DATE: 2/6/20	QUOTE: 171129-876	190075	G2
---------------------------------------------------------	-------------	------------	--------------	--------------	-------------------	--------	----

REBUD PUMP STATION
42" TRANSMISSION WATER LINE (850PP) - PHASE 2
MCKINNEY, TEXAS

MISCELLANEOUS MATERIALS

SHIP LOOSE MATERIALS					QUANTITY OF ITEM TO BE SHIPPED FOR EACH PIECE NUMBER																	
ITEM NO	QUANTITY THIS DWG	DESCRIPTION	MATERIAL SPECIFICATION	REF SHEET	A101	B104	B112	A116	A201	LX205	B210	A214	A301	A311	A312	A401	A416	A501	503	5509	A513	
					L1	L1	L1	L1	L2	L2	L2	L2	L3	L3	L3	L4	L4	L5	L5	L5	L5	L5
1	44	30" L-301 POLYISOPRENE LAYING GASKET (21/32")	AWWA C301	-																		
2	3	NSF APPROVED JOINT LUBRICANT (25 LB PAIL)		-																		
3	37	30" L-301 FOAM LINED DIAPER (12" WIDE)		-																		
4	557	3/8" BAR FOR FIELD WELDED JOINTS (FT)	ASTM A615 GRADE 40	-																		
5	7	30" L-301 FOAM LINED DIAPER (18" WIDE)		-																		
6	27	20" B-303 POLYISOPRENE LAYING GASKET (21/32")	AWWA C303	-																		
7	24	30" B-303 POLYISOPRENE LAYING GASKET (21/32")	AWWA C303	-																		
8	19	30" B-303 FOAM LINED DIAPER (12" WIDE)		-																		
9	5	30" B-303 FOAM LINED DIAPER (18" WIDE)		-																		
10	3	20" B-303 FOAM LINED DIAPER (18" WIDE)		-																		
11	11	20" B-303 FOAM LINED DIAPER (12" WIDE)		-																		
12																						
13	6	30" L-301 TYPAR DIAPER (24" WIDE)		-																		
14	6	30" L-301 HARNESS CLAMP (CODE: JFM)		-																		
15	4	30" HOLD MIDDLE RING (10" x 3/16" MIDDLE RING)		D18-A																		
16	3	30" B-303 TYPAR DIAPER (24" WIDE)		-																		
17																						
18																						
19																						
20																						

NO.	REVISION	DATE	BY	CHK

RELEASED COPY ISSUED FOR FABRICATION NOV 13, 2020	SCALE: NONE	DRAWN: JMF	CHECKED: JMF	DATE: 9/1/20	QUOTE: 1901121-161	207341	SL1
---------------------------------------------------------	-------------	------------	--------------	--------------	--------------------	--------	-----

WATER MAIN REPLACEMENTS FOR THE SM WRIGHT
PHASE II & IIB PROJECT
DALLAS, TX



SUGGESTED CONCRETE PRESSURE PIPE SPECIFICATIONS

The following are suggested technical specifications that can be used by engineers and owners for prestressed concrete cylinder pipe (both L-301 and E-301) and bar-wrapped concrete cylinder pipe. Microsoft Word versions of these specifications can be obtained from your Thompson Pipe Group Sales Representative.

PRESTRESSED CONCRETE CYLINDER PIPE

PART 1 – GENERAL

1.01 SCOPE OF WORK

- A. Contractor shall furnish all labor, materials, tools, equipment, and incidentals necessary to install, ready for operation, all prestressed concrete cylinder pipe including fittings, rubber gaskets, mortar for joints of all pipe as shown on the drawings and as specified herein. The work shall include the testing of materials, pipe and pipelines.

1.02 RELATED WORK

- A. Trenching, backfilling, and compaction are included in Section ____.
- B. Fill materials are included in Section ____.
- C. Valves and appurtenances are included in Section ____.

1.03 SUBMITTALS

- A. Submit shop drawings to the engineer for review in accordance with Section ____ showing details of reinforcement, concrete, and joint dimensions for all pipe and fittings. Submit a tabulated laying schedule which references stationing and elevations as shown on the drawings as well as all fittings, bevels, restrained joints, and specials, along with the manufacturer's drawings indicating details of all items. The above shall be submitted to the engineer for review before manufacture and shipment. The locations of all pipes shall conform to the locations indicated on the drawings. Pipe supplied from inventory shall be authorized by the engineer.
- B. Submit anticipated production and delivery schedule.
- C. Design Data:
 - 1. Design specification data sheets listing all parameters used in the pipe design.
 - a. Type of Pipe
 - 1) Lined Cylinder (L-301)
 - 2) Embedded Cylinder (E-301)

- b. Cylinder Data
 - 1) Thickness and diameter
- c. Prestressing Wire Data
 - 1) ASTM designation and class
 - 2) Size
 - 3) Area
 - 4) Wire spacing
 - 5) Minimum ultimate strength
 - 6) Wrapping stress
- d. Concrete/Mortar Data
 - 1) Concrete proportions
 - 2) Minimum compressive strength at time of wrapping
 - 3) Minimum compressive strength at 28 days
 - 4) Core thickness
 - 5) Coating thickness

2. Submit design calculations in accordance with AWWA C304. Clearly indicate all calculation constants for this specific project.

D. Test Reports

- 1. Shop test results for cylinder steel, prestressing wire, cement, and gasket rubber
- 2. Field pressure/leakage tests

E. Certificates

- 1. Prior to shipment of pipe, submit a certified affidavit of compliance stating that the pipe for this contract was manufactured, inspected, and tested in accordance with the AWWA standards specified herein.

1.04 REFERENCE STANDARDS

- A. The AWWA Standard for prestressed concrete pressure pipe, steel-cylinder type (AWWA C301, latest revision) is made a part of these specifications. Documents referenced in AWWA C301, Section 2 form a part of this specification to the extent specified herein.
- B. Other standards applicable to the work specified herein are, but not limited to, the following:
 - 1. AWWA C301 – Prestressed Concrete Cylinder Pipe, Steel-Cylinder Type
 - 2. AWWA C304 – Design of Prestressed Concrete Cylinder Pipe

3. AWWA C651 – Disinfecting of Water Mains
 4. AWWA Manual M9 – Concrete Pressure Pipe
- C. American Society for Testing and Materials (ASTM)
1. ASTM A648 – Standard Specification for Steel Wire, Hard Drawn for Prestressing Concrete Pipe
 2. ASTM C33 – Standard Specification for Concrete Aggregates
 3. ASTM C150 – Standard Specification for Portland Cement
 4. ASTM A1011 – Standard Specification for Steel, Sheets and Strip, Hot-Rolled, Carbon, Structural, High-Strength Low-Alloy and High-Strength Low-Alloy with Improved Formability
 5. ASTM A659 – Standard Specification for Steel, Carbon (0.16 Maximum to 0.25 Maximum Percent), Hot-Rolled Sheet and Strip, Commercial Quality
 6. ASTM A1018 – Standard Specification for Steel, Sheet and Strip, Heavy-Thickness Coils, Hot-Rolled, Carbon, Commercial, Drawing, Structural, High-Strength Low-Alloy, and High-Strength Low-Alloy with Improved Formability
- D. American Association of State Highway and Transportation Officials (AASHTO)
- E. Where reference is made to one of the above standards, the revision in effect at the time of bid opening shall apply.

1.05 QUALITY ASSURANCE

- A. Qualification
1. The materials specified herein are intended to be standard types of prestressed concrete cylinder pipe and fittings for use in transporting water.
 2. All prestressed concrete cylinder pipe and fittings shall be furnished by reputable manufacturers with a minimum of ten years of experience in manufacturing prestressed concrete cylinder pipe. The manufacturing plant shall have a current Lloyd's Register Audit Certification for the manufacture of prestressed concrete cylinder pipe. Additionally, the pipe manufacturer shall be a member of the American Concrete Pressure Pipe Association. The pipe and fittings shall be manufactured and installed in accordance with industry standards and methods and shall comply in all respects with requirements of these specifications and with the latest edition of all referenced standards and specifications.
- B. Inspection of the pipe and fittings will be made by the engineer upon delivery at the site. The pipe shall be subject to rejection at any time on account of failure to meet any of the specification requirements. Pipe rejected after delivery shall be marked for identification and shall be repaired or removed from the job at once unless otherwise approved by the engineer.

PART 2 – PRODUCTS

2.01 MATERIALS

- A. Unless otherwise specified, the design materials and workmanship for pipe shall conform to the requirements of AWWA C301. Core and coating thickness for pipe shall be as specified in AWWA C301.
- B. Prestressed concrete cylinder pipe and fittings shall be manufactured by Thompson Pipe Group, Grand Prairie, TX or equal.
- C. Design Conditions
 - 1. Pipe shall be designed in accordance with the AWWA C304 Standard, using the following design conditions; these conditions shall also be used in designing fittings that include a portland cement mortar interior and exterior coating of the steel cylinder:
 - a. External Loading
 - 1) The earth load shall be taken as the greater of the following:
 - a) Depth from existing ground level to top of pipe as shown on plans, or
 - b) Five feet minimum in all cases.
 - 2) Earth loads shall be computed using the following parameters:
 - a) Unit Soil Weight = 120 pounds per cubic foot
 - b) TYPE R__ Bedding (Note: Prestressed Concrete Cylinder Pipe (PCCP) is designed as a rigid structure thus it does not rely on soil side support (as do flexible pipe materials such as steel, ductile iron and plastic) to enable it to handle external loads. The bedding and backfill details on the plans should reflect this in order to obtain an economical design for the client.)
 - c) Bedding angle = __° (Note: The five bedding details for PCCP are contained in the AWWA C304 design standard and in the AWWA M9 Manual for Concrete Pressure Pipe. At moderate earth covers, Type R3 or R4 bedding is usually sufficient.)
 - 3) Live loads shall be calculated as:
 - a) Pipe in streets and other paved areas: AASHTO HS20 for two trucks passing
 - b) Pipe within railroad right-of-way: AREA Cooper E80
 - c) Both HS20 and E-80 live loads shall be computed in accordance with the American Concrete Pipe Association *Concrete Pipe Design Manual* or *Concrete Pipe Handbook*.
 - b. Internal Pressure
 - 1) Design working pressure (Pw) shall be ___ psi (Note: The AWWA C304 design standard for PCCP requires the actual system working pressure for design purposes. The working pressure does not need to be artificially increased since the C304 standard already contains appropriate safety factors.)

- 2) Surge Pressure (Pt) shall be ____ psi. (Note: The surge pressure here is to be expressed as that pressure over and above the working pressure that can occur during a transient event. As a minimum, the AWWA C304 standard requires us to use a pressure of 40% of the working pressure or 40 psi, whichever is higher.)
- 3) Field Test Pressure (Pft) shall be ____ psi. (Note: The field test pressure is recommended to not exceed 20% above the working pressure. This recommendation is contained in the AWWA M9 Manual for concrete pressure pipe.)

D. Fittings

1. Steel thickness of all fittings shall be designed in accordance with Chapter 8 of the AWWA M9 Manual. Fittings shall be designed for the same conditions as the adjacent pipe.
2. Fabrication of the fittings shall be as per AWWA M9 Manual and C301.
3. Interior and exterior concrete/mortar coating shall be as per AWWA C301.

E. The date of manufacture and a serial number traceable to the date of manufacture and the design strength classification shall be clearly marked by stencil with waterproof paint at the end of the pipe barrel. Non-compliant or damaged pipe will be permanently rejected, repaired in the field if permitted by the engineer and the pipe manufacturer, or returned to the pipe plant for repairs. Pits, blisters, rough spots, minor concrete or mortar breakage, and other imperfections may be repaired unless prohibited by the engineer. Repairs shall be carefully inspected before final approval. Cement mortar used for repairs shall have a minimum compressive strength of 3,000 psi at the end of 7 days and 4,500 psi at the end of 28 days, when tested in cylinders stored in the standard manner. Major breakage or spalling from interior of pipe may be reason for the rejection of pipe. Pipe may be repaired under unloaded conditions (removal of prestressing wire) by or under the supervision of a representative of the pipe manufacturer. Cement mortar used for repair shall have a minimum compressive strength of 3,000 psi at 7 days and 4,500 psi at 28 days when tested as standard cylinders.

F. Cement shall be Type II and shall be in accordance with ASTM C150.

G. The pipe core shall be produced by the centrifugal method or the vertical casting method.

H. Wire shall be a minimum of No.6 gauge and shall meet the requirements of ASTM A648, Class III. Wire of a class strength greater than Class III will not be permitted.

I. Steel cylinders shall be No. 16 gauge minimum thickness and shall be hot rolled.

J. Mortar coating shall consist of one part cement to a maximum of three parts fine aggregate by weight. Rebound not to exceed one fourth of the total mix weight may be used provided the rebound is used as a replacement for fine aggregate.

K. Bell and spigot joint rings shall be steel, self-centering type, and otherwise specified in AWWA C301. Surfaces of the joint rings that will be exposed after fabrication is complete shall receive a zinc metalized coating of 4 mils thickness (0.004"). In areas of the alignment where the pipe will be subject to unbalanced hydrostatic thrust (bends, tees, bulkheads, wyes, and some valves), the pipe joints shall be restrained (harnessed) by field welding joints or by mechanically restrained joints.

Lengths of restrained joint pipe shall be determined using the computational method as contained in Chapter 9 of the AWWA M9 Manual for Concrete Pressure Pipe. The steel cylinder thickness in pipe sections between the location of the maximum thrust force and the end of the harnessed section will be prorated on the basis of zero longitudinal thrust at the end of the harnessed section.

Two acceptable types of mechanically harnessed or restrained joints are the harness clamp and Snap Ring® types of flexible restrained joints. The clamp type restrained joint consists of two semicircular steel clamps which fit over steel lugs that are factory welded or rolled into the steel bell and spigot sections. The semicircular clamps are drawn together by bolts at the springline on both sides of the pipe to form a flexible restrained joint.

The Snap Ring® flexible restrained joint consists of a split steel ring which is recessed in the special steel bell section of the pipe until the joint is made. Once the joint is made, the split steel ring is drawn down into position to form a lock between the bell and spigot by tightening a single steel bolt.

Both joint types shall be capable of transmitting the longitudinal thrust forces due to working pressure and test pressure and must be encased in grout after the joint has been completed and before the line is pressurized using special grout bands supplied by the pipe manufacturer.

Joints may be field welded for thrust restraint during initial installation. This can be accomplished from inside the pipe or outside the pipe as recommended by the pipe manufacturer and applicable safety regulations.

- L. The rubber o-ring gaskets shall be manufactured and supplied in accordance with AWWA C301 and shall be designed and manufactured so that the completed joint will withstand an internal water pressure in excess of the highest pressure to which the pipe will be subjected without showing any leakage by the gasket or displacement of it.
- M. Bell and spigot wall fittings shall be the manufacturer's standard design. Wall fittings shall be supplied with adequate bracing to keep them round and true during transportation and installation. A waterstop/seep ring shall be included if indicated.
- N. Alignment for long-radius, curved sections as specified on the drawings may be produced by joint deflections of joints not to exceed that recommended by the manufacturer. Required deflections which are in excess of those recommendations shall be produced by beveling the spigot end of the pipe.

PART 3 – EXECUTION

3.01 GENERAL

- A. Care shall be taken during loading, transporting, and unloading to prevent injury to the pipes, fittings, or coatings. Pipe or fittings shall not be dropped. All pipe and fittings shall be thoroughly cleaned before laying, shall be kept clean until they are used in the work, and when laid, shall conform to the lines and grades shown on the drawings.
- B. If any damaged pipe is discovered after it has been laid, it shall be repaired in a satisfactory manner if permitted by the pipe manufacturer and the engineer or it shall be removed and replaced with a sound pipe.
- C. Regulate and control equipment and construction operations such that the live loading on the pipe does not exceed the loads for which the pipe is designed and manufactured. Pipe found to have longitudinal cracks from construction equipment or other loading exceeding those allowed by the design under AWWA C304 shall be removed from the line and replaced with sound pipe and closures as required.
- D. The method of jointing the pipe shall be in strict accordance with the manufacturer's instructions. Arrange for the manufacturer's representative to provide installation training for the Contractor's crew prior to the start of pipe installation. The manufacturer's representative shall be on the jobsite and witness installation on the first day.
- E. Pipe Manufacturer's Field Service Representative:
 - 1. Pipe manufacturer shall provide a qualified field service representative, who shall be available to be on the project site, with proper notice, from the contractor's, engineer's, or owner's representative.
 - 2. The field service representative, who shall be an employee of the pipe manufacturer, must have experience as a representative of the pipe manufacturer in the area of providing such services.
 - 3. It is the intent of the owner to be assured that the installation of this pipeline is performed in accordance with the specified standards and manufacturer's recommendations. Good installation procedures will assure integrity of the pipeline with the minimum amount of pipe joints required for completion of the main. Therefore, the contractor shall include in their bid as a minimum that the pipe manufacturer's field service representative will be on-site for the following periods:
 - a) Initial construction training and monitoring.
 - b) Provide problem-solving assistance during construction.

3.02 INSTALLING PRESTRESSED CONCRETE CYLINDER PIPE AND FITTINGS

- A. Prestressed concrete cylinder pipe and fittings shall be installed in accordance with requirements of AWWA M9, except as otherwise provided herein. A firm, even bearing throughout the length of the pipe shall be provided by tamping select fill in the haunch area and at the side of the pipe to achieve the required bedding support angle. **BLOCKING WILL NOT BE PERMITTED.**

- B. All prestressed concrete cylinder pipe shall have a minimum of 3½ feet of cover. Pipe shall be laid to the elevations shown on the drawings unless approved otherwise by the Engineer. Small construction equipment (pick-up trucks, track hoes, front-end loaders, small tracked tractors, etc.) shall not be operated over newly-installed pipe until at least three (3) feet of earth cover has been placed over the top of the pipe.
- C. The pipe interior shall be maintained dry and broom clean throughout the construction period.
- D. Gasket, gasket groove, and bell sealing surfaces shall be cleaned and lubricated with a lubricant furnished by the pipe manufacturer. The lubricant shall be approved for use in potable water and shall be harmless to the rubber gasket. Use only lubricant supplied by the pipe manufacturer. Gasket shall be equalized prior to homing joint. Pipe shall be laid with bell ends looking ahead in the direction of laying. As soon as the spigot ring is centered in the bell of the previously laid pipe, it shall be forced home with approved equipment. After the gasket is compressed, verify the position of the gasket in the spigot ring groove with a feeler gage provided by the pipe manufacturer.
- E. The grout diaper for PCCP shall consist of a Tyvar synthetic fabric layer (gray in color) and a layer of closed cell foam. These layers are sewn together along with a pair of 5/8" wide steel bands at each edge which are used to secure the diaper to the pipe exterior. Use only grout diapers supplied by the pipe manufacturer. A stretching tool is used to tighten the steel bands. Once the bands are pulled tight, a steel clip is crimped around the bands to hold them in position. It is important that the diaper be carefully placed against the exterior surface of the pipe to ensure that it is flush with no gaps or gathers. The closed cell foam surface is to be placed against the pipe exterior.

The wet grout will flow down to the bottom of the diaper and begin to bulge it out. It is often helpful to place some bedding material (or sandbags) directly under the diaper at the bottom to support the weight of the wet grout. Take care to not push excessive amounts of bedding material under the diaper such that the diaper is pushed up into the joint recess impeding the flow of wet grout.

Mix the grout using one part ASTM C150 Type 1 or Type 2 portland cement to not more than three parts clean sand with sufficient water to achieve a pourable consistency. The grout should look and pour like a thick cream. Carefully pour the mixed grout into the gap at the top of the diaper. As the pouring proceeds, the workers must examine the diaper around the joint periphery to ensure that the grout is flowing all around. Once the diaper is full and wet grout is puddling at the gap at the top, apply a stiffer mix the consistency of wet brick mortar over the joint insuring that all steel components of the joint are covered.

- F. All pipe shall be sound and clean before laying. When laying is not in progress, including lunchtime, the open ends of the pipe shall be closed by watertight plug or other approved means to prevent unauthorized entrance of people, animals, dirt, or water into the pipeline already installed. Good alignment shall be preserved in laying. The deflections at joints shall not exceed the amount recommended by the pipe manufacturer.

3.03 TESTING

- A. The completed pipeline (or completed sections of the pipeline) shall be bulkheaded, filled with water, and pressure tested to the stipulated field test pressure. After the line is filled, and prior to pressure testing, it shall be allowed to soak under low pressure to allow the pipe walls to absorb water and permit temperature stabilization. While filling the line, the contractor shall be responsible for properly bleeding off trapped air to avoid adversely affecting the leakage test results.

During the hydrostatic test, the contractor shall use a calibrated meter or other device to accurately measure the quantity of water necessary to maintain the test pressure on the gauge. The line will not be accepted until this measured quantity is less than 10 gallons per inch of diameter per mile of pipe per 24 hours. All visible leaks must be repaired regardless of the measured leakage.

3.04 CLEANING

- A. At the conclusion of the work, thoroughly clean all of the new pipelines by flushing with water or other means to remove all dirt, stones or other debris which may have entered during the construction period. If, after this cleaning, obstructions remain, they shall be removed.

BAR-WRAPPED CONCRETE CYLINDER PIPE

PART 1 – GENERAL

1.01 SCOPE OF WORK

- A. Contractor shall furnish all labor, materials, tools, equipment, and incidentals necessary to install, ready for operation, all bar-wrapped concrete cylinder pipe including fittings, rubber gaskets, and mortar for joints of all pipe as shown on the drawings and as specified herein. The work shall include the testing of materials, pipe and pipelines.

1.02 RELATED WORK

- A. Trenching, Backfilling, and Compaction are included in Section ____.
- B. Fill Materials are included in Section ____.
- C. Valves and Appurtenances are included in Section ____.

1.03 SUBMITTALS

- A. Submit shop drawings to the engineer for review in accordance with Section ____ showing details of reinforcement, concrete, and joint dimensions for all pipe and fittings. Submit a tabulated laying schedule which references stationing and elevations as shown on the drawings as well as all fittings, bevels, restrained joints, and specials, along with the manufacturer's drawings indicating details of all items. The above shall be submitted to the engineer for review before manufacture and shipment. The locations of all pipes shall conform to the locations indicated on the drawings. Pipe supplied from inventory shall be authorized by the engineer.
- B. Submit anticipated production and delivery schedule.
- C. Design Data:
 - 1. Design specification data sheets listing all parameters used in the pipe design.
 - a. Type of Pipe
 - 1) Concrete Pressure Pipe, Bar-Wrapped Steel-Cylinder type
 - b. Cylinder Data
 - 1) Thickness and diameter
 - c. Bar Reinforcement Data
 - 1) Size
 - 2) Area
 - 3) Bar spacing
 - d. Concrete/Mortar Data
 - 1) Concrete/mortar proportions

- 2) Lining thickness
 - 3) Coating thickness
2. Submit design calculations in accordance with AWWA M9 Manual for Concrete Pressure Pipe, Chapter 7. Clearly indicate all calculation constants for this specific project.
- D. Test Reports
1. Shop test results for cylinder steel, reinforcing bar, cement, and gasket rubber
 2. Field pressure/leakage tests
- E. Certificates
1. Prior to shipment of pipe, submit a certified affidavit of compliance stating that the pipe for this contract was manufactured, inspected, and tested in accordance with the AWWA standards specified herein.

1.04 REFERENCE STANDARDS

- A. The AWWA Standard for Concrete Pressure Pipe, Bar-Wrapped, Steel-Cylinder Type (AWWA C303, latest revision) is made a part of these Specifications. Documents referenced in AWWA C303, Section 2 form a part of this specification to the extent specified herein.
- B. Other standards applicable to the work specified herein are, but not limited to, the following:
1. AWWA C303 – Concrete Pressure Pipe, Bar-Wrapped, Steel-Cylinder Type
 2. AWWA C651 – Disinfecting of Water Mains
 3. AWWA Manual M9 – Concrete Pressure Pipe
- C. American Society for Testing and Materials (ASTM)
1. ASTM A615 – Standard Specification for Deformed and Plain Billet-Steel Bars for Concrete Reinforcement
 2. ASTM C33 – Standard Specification for Concrete Aggregates
 3. ASTM C150 – Standard Specification for Portland Cement
 4. ASTM A659 – Standard Specification for Commercial Steel (CS), Sheet and Strip, Carbon (0.16 Maximum to 0.25 Maximum Percent, Hot-Rolled
 5. ASTM A1018 – Standard Specification for Steel, Sheet and Strip, Heavy-Thickness Coils, Hot-Rolled, Carbon, Commercial, Drawing, Structural, High-Strength Low-Alloy, and High-Strength Low-Alloy with Improved Formability
 6. ASTM A1011 – Standard Specification for Steel, Sheets and Strip, Hot-Rolled, Carbon, Structural, High-Strength Low-Alloy and High-Strength Low-Alloy with Improved Formability
 7. ASTM A283 – Standard Specification for Low and Intermediate Tensile Strength Carbon Steel Plates

8. ASTM A285 – Standard Specification for Pressure Vessel Plates, Carbon Steel, Low- and Intermediate-Tensile Strength
 9. ASTM A36 – Standard Specification for Carbon Structural Steel
- D. American Association of State Highway and Transportation Officials (AASHTO)
- E. Where reference is made to one of the above standards, the revision in effect at the time of bid opening shall apply.

1.05 QUALITY ASSURANCE

A. Qualification

1. The materials specified herein are intended to be standard types of bar-wrapped concrete cylinder pipe and fittings for use in transporting water.
 2. All bar-wrapped concrete cylinder pipe and fittings shall be furnished by reputable manufacturers with a minimum of ten years of experience in manufacturing bar-wrapped concrete pressure pipe. The manufacturing plant shall have a current Lloyd's Register Audit Certification for the manufacture of bar-wrapped pipe. Additionally, the pipe manufacturer shall be a member of the American Concrete Pressure Pipe Association. The pipe and fittings shall be manufactured and installed in accordance with industry standards and methods and shall comply in all respects with requirements of these specifications and with the latest edition of all referenced standards and specifications.
- B. Inspection of the pipe and fittings will be made by the engineer upon delivery at the site. The pipe shall be subject to rejection at any time on account of failure to meet any of the specification requirements. Pipe rejected after delivery shall be marked for identification and shall be repaired or removed from the job at once unless otherwise approved by the engineer.

PART 2 – PRODUCTS

2.01 MATERIALS

- A. Unless otherwise specified, the design materials and workmanship for pipe shall conform to the requirements of AWWA C303. Lining and coating thickness for pipe shall be as specified in AWWA C303.
- B. Bar-wrapped concrete cylinder pipe and fittings shall be manufactured by Thompson Pipe Group, Grand Prairie, TX or equal.
- C. Design Conditions
 - 1. Pipe shall be designed in accordance with the AWWA M9 Manual Chapter 7, using the following design conditions; these conditions shall also be used in designing fittings that include a portland cement mortar interior and exterior coating of the steel cylinder:
 - a. External Loading
 - 1) The earth load shall be taken as the greater of the following:
 - a) Depth from existing ground level to top of pipe as shown on plans, or
 - b) Five feet minimum in all cases.
 - 2) Earth loads shall be computed assuming a trench width of pipe outside diameter plus 2 feet using the following parameters:
 - a) Unit Soil Weight = 120 pounds per cubic foot
 - b) $r_{sd}p = 0.50$ $K\mu = 0.19$
 - 3) Deflection calculations shall be based on the following:
 - a) Bedding as recommended by the pipe manufacturer.
 - b) Bedding constant = 0.085
 - c) $E' = 1000$ psi
 - 4) Live loads shall be calculated as:
 - a) Pipe in streets and other paved areas: AASHTO HS20 for two trucks passing
 - b) Pipe within railroad right-of-way: AREA Cooper E80
 - c) Both HS20 and E80 live loads shall be computed in accordance with the American Concrete Pipe Association *Concrete Pipe Design Manual* or *Concrete Pipe Handbook*.
 - b. Internal Pressure
 - 1) Design working pressure (Pw) shall be ____ psi (Note: The AWWA M9 Manual design standard for B-303 requires the actual system working pressure for design purposes. The working pressure does not need to be artificially increased.)

- 2) Surge pressure (Pt) shall be ____ psi. (Note: (The surge pressure here is to be expressed as that pressure over and above the working pressure that can occur during a transient event. As a minimum, we suggest using a pressure of 40% of the working pressure or 40 psi, whichever is higher.)
- 3) Field test pressure (Pft) shall be ____ psi. (Note: The field test pressure is recommended to be no more than 20% above the working pressure. This recommendation is contained in the AWWA M9 Manual for concrete pressure pipe.)

D. Fittings

1. Steel thickness of all fittings shall be designed in accordance with Chapter 8 of the AWWA M9 Manual. Fittings shall be designed for the same conditions as the adjacent pipe.
2. Fabrication of the fittings shall be as per AWWA M9 Manual and C303.
3. Interior and exterior mortar coating shall be as per AWWA C303.

E. The date of manufacture or a serial number traceable to the date of manufacture and the design strength classification shall be clearly marked by stencil with waterproof paint at the end of the pipe barrel. Non-compliant or damaged pipe will be permanently rejected, repaired in the field if permitted by the engineer and the pipe manufacturer or returned to the pipe plant for repairs. Pits, blisters, rough spots, minor concrete or mortar breakage, and other imperfections may be repaired unless prohibited by the engineer. Repairs shall be carefully inspected before final approval. Cement mortar used for repairs shall have a minimum compressive strength of 3,000 psi at the end of 7 days and 4,500 psi at the end of 28 days, when tested as standard cylinders stored in the standard manner.

F. Portland cement shall be Type II and shall be in accordance with ASTM C150.

G. The pipe lining shall be placed by the centrifugal method.

H. Steel cylinders shall be as required in the AWWA C303 standard.

I. Mortar coating shall consist of one part cement to a maximum of three parts fine aggregate by weight.

J. Bell and spigot joint rings shall be steel, self-centering type, and as otherwise specified in AWWA C303. In areas of the alignment where the pipe will be subject to unbalanced hydrostatic thrust forces (bends, tees, bulkheads, wyes, and valves), the pipe joints shall be restrained (harnessed) by field welding joints or by mechanically restrained joints.

Restrained joint pipe lengths shall be calculated as described in the AWWA M9 Manual Chapter 9, latest edition. The steel cylinder thickness in pipe sections between the location of the maximum thrust and the end of the harnessed section will be prorated on the basis of zero longitudinal thrust at the end of the harnessed section.

Two acceptable types of mechanically harnessed or restrained joints are the harness clamp and Snap Ring® types of flexible restrained joints. The clamp type consists of two semicircular steel clamps which fit over steel lugs that are factory welded or rolled into the steel bell and spigot sections. The semicircular clamps are drawn together by bolts at the springline on both sides of the pipe to form a flexible restrained joint.

The Snap Ring® flexible restrained joint consists of a split steel ring which is recessed in the special steel bell section of the pipe until the joint is made. Once the joint is made, the split steel ring is drawn down into position to form a lock between the bell and spigot by tightening a single steel bolt.

Both joint types shall be capable of transmitting the longitudinal thrust forces due to working pressure and test pressure and must be encased in grout before the line is pressurized using special grout bands supplied by the pipe manufacturer.

Field welding of specific joints (ie. closure assemblies) for thrust restraint during the initial installation can be done from inside the pipe or outside the pipe as permitted by the pipe manufacturer and applicable safety regulations.

- K. The rubber gaskets shall be in accordance with AWWA C303 and shall be manufactured and supplied so that the completed joint will withstand an internal water pressure in excess of the highest pressure to which the pipe will be subjected without showing any leakage by the gasket or displacement of it.
- L. Bell and spigot wall fittings shall be the manufacturer's standard design. Wall fittings shall be supplied with adequate bracing to keep them round and true during transportation and installation. A waterstop/seep ring shall be included if indicated.
- M. Alignment for long-radius, curved sections as specified on the drawings may be produced by joint deflections of joints not to exceed that recommended by the manufacturer. Required deflections which are in excess of those recommendations shall be produced by beveling the spigot ends of the pipe.
- N. Pipe shall be supplied in nominal lengths as per the pipe manufacturer's standard fabrication practices. However, laying length shall not exceed 35 feet.

PART 3 – EXECUTION

3.01 GENERAL

- A. Care shall be taken during loading, transporting, and unloading to prevent injury to the pipes, fittings, or coatings. Pipe or fittings shall not be dropped. All pipe and fittings shall be thoroughly cleaned before laying, shall be kept clean until they are used in the work, and when laid, shall conform to the lines and grades shown on the drawings.
- B. If any damaged pipe is discovered after it has been laid, it shall be repaired in a satisfactory manner if permitted by the pipe manufacturer and the engineer or it shall be removed and replaced with a sound pipe.
- C. Regulate and control equipment and construction operations such that the live loading on the pipe does not exceed the loads for which the pipe is designed and manufactured. Pipe found to have deflections from construction equipment or other loading exceeding those allowed by AWWA C303 shall be removed from the line and replaced with sound pipe and closures as required.
- D. The method of jointing the pipe shall be in strict accordance with the manufacturer's instructions. Arrange for the manufacturer's representative to provide installation training for the contractor's crew prior to the start of pipe installation. The manufacturer's representative shall be on the jobsite and witness installation on the first day.
- E. Pipe Manufacturer's Field Service Representative:
 - 1. Pipe manufacturer shall provide a qualified field service representative, who shall be available to be on the project site, with proper notice, from the contractor's, engineer's, or owner's representative.
 - 2. The field service representative, who shall be an employee of the pipe manufacturer, must have documented experience as a representative of the pipe manufacturer in the area of providing such services.
 - 3. It is the intent of the owner to be assured that the installation of this pipeline is performed in accordance with the specified standards and manufacturer's recommendations. Good installation procedures will assure integrity of the pipeline with the minimum amount of pipe joints required for completion of the main. Therefore, the contractor shall include in their bid as a minimum that the pipe manufacturer's field service representative will be on-site for the following periods:
 - a) Initial construction training and monitoring.
 - b) Provide problem-solving assistance during construction.

3.02 INSTALLING BAR-WRAPPED CONCRETE CYLINDER PIPE AND FITTINGS

- A. Bar-wrapped concrete cylinder pipe and fittings shall be installed in accordance with requirements of AWWA M9, except as otherwise provided herein. A firm, even bearing throughout the length of the pipe shall be provided by tamping select fill in the haunch area at the side of the pipe to achieve the required bedding support angle. BLOCKING WILL NOT BE PERMITTED.

- B. All bar-wrapped concrete cylinder pipe shall have a minimum of three and one-half feet of cover before any small construction equipment is operated over the top. Pipe shall be laid to the elevations shown on the drawings unless approved otherwise by the engineer.
- C. The pipe interior shall be maintained dry and broom clean throughout the construction period.
- D. Gasket, gasket groove, and bell sealing surfaces shall be cleaned and lubricated with a lubricant furnished by the pipe manufacturer. The lubricant shall be approved for use in potable water and shall be harmless to the rubber gasket. Use only lubricant supplied by the pipe manufacturer. Pipe shall be laid with bell ends looking ahead in the direction of laying. As soon as the spigot ring is centered in the bell of the previously laid pipe, it shall be forced home with approved equipment. After the gasket is compressed, verify the position of the gasket in the spigot ring groove with a feeler gage provided by the pipe manufacturer.
- E. The grout diaper for BWP shall consist of a Typar synthetic fabric layer (gray in color) and a layer of closed cell foam. These layers are sewn together along with a pair of 5/8" wide steel bands at each edge which are used to secure the diaper to the pipe exterior. Use only grout diapers supplied by the pipe manufacturer. A stretching tool is used to tighten the steel bands. Once the bands are pulled tight, a steel clip is crimped around the bands to hold them in position. It is important that the diaper be carefully placed against the exterior surface of the pipe to ensure that it is flush with no gaps or gathers. The closed cell foam surface is to be placed against the pipe exterior.

The wet grout will flow down to the bottom of the diaper and cause it to bulge out. It is often helpful to place some bedding material (or sandbags) directly under the diaper at the bottom to support the weight of the wet grout. Take care to not push excessive amounts of bedding material under the diaper such that the diaper is pushed up into the joint recess, impeding the flow of wet grout.

Mix the grout using one part ASTM C150 Type 1 or Type 2 portland cement to not more than three parts clean sand with sufficient water to achieve a pourable consistency. The grout should look and pour like a thick cream. Carefully pour the mixed grout into the gap at the top of the diaper. As the pouring proceeds, the workers must examine the diaper around the joint periphery to ensure that the grout is flowing all around. Once the diaper is full and wet grout is puddling at the gap at the top, apply a stiffer mix the consistency of wet brick mortar over the joint and insure that all steel components of the joint are covered.

- F. All pipe shall be sound and clean before laying. When laying is not in progress, including lunchtime, the open ends of the pipe shall be closed by watertight plug or other approved means to prevent unauthorized entrance of people, animals, dirt, or water into the pipeline already installed. Good alignment shall be preserved in laying. The deflections at joints shall not exceed the amount recommended by the pipe manufacturer.

3.03 TESTING

- A. The completed pipeline (or completed sections of the pipeline) shall be bulkheaded, filled with water, and pressure tested to 120 percent of the internal working pressure. After the line is filled, and prior to pressure testing, it shall be allowed to soak under low pressure to allow the pipe walls to absorb water and permit temperature stabilization. While filling the line, the contractor shall be responsible for properly bleeding off trapped air to avoid adversely affecting the leakage test results.

During the hydrostatic test, the contractor shall use a calibrated meter or other device to accurately measure the quantity of water necessary to maintain the test pressure on the gauge. The line will not be accepted until this measured quantity is less than 10 gallons per inch of diameter per mile of pipe per 24 hours. All visible leaks must be repaired regardless of the measured leakage.

3.04 CLEANING

- A. At the conclusion of the work, thoroughly clean all of the new pipelines by flushing with water or other means to remove all dirt, stones or other debris which may have entered during the construction period. If, after this cleaning, obstructions remain, they shall be removed.

SUGGESTED CONCRETE PRESSURE PIPE SPECIFICATIONS

Bar-Wrapped Concrete Cylinder Pipe Suggested Applications

Application	Prestressed Concrete Cylinder Pipe	Bar-Wrapped Concrete Cylinder Pipe
Raw and Potable Fresh Water Lines	✓	✓
Treated Sewer Effluent Lines	✓	✓
Gravity Raw Sewage Lines	✓	
Pressure Raw Sewage Lines	✓	
Seawater Lines	✓	✓
Power Plant Cooling Water Lines	✓	✓
Power Plant Make-Up Water Lines	✓	✓
Water Impoundment Dam Principal Spillway Pipe	✓	
Treatment Plant Process Pipe	✓	✓
Industrial Plant Process Pipe	✓	✓
Tunnel Carrier Pipe	✓	✓
Chilled Water Lines	✓	✓
Subaqueous Intake and Outfall Lines	✓	✓
Pile Supported Lines	✓	✓



PIPELINE SERVICES AND EMERGENCY REPAIR

Thompson Pipe Group offers its customers the assistance of experienced field service representatives. They are available for consultation before or during pipe installation, tapping lines while in or out of service, and assistance in the repair of damaged pipe sections occurring either during installation or in operation.

This section contains information on the field welding of joints, repair sections, and on repair saddles. Further information on follower ring closures, field welded closures, and field welded butt strap closures can be found in Section 11 and short pipe are discussed in Section 3. Tapping is detailed in Section 15. For more detailed information, refer to the Thompson Pipe Group Pipeline Services Repair Guide.

WELDED JOINTS

There are circumstances, where it is necessary to weld a joint in the field. These circumstances may include thrust restraint or the repair of joints. Other types of restrained joints as shown in Section 4 are recommended for thrust restraint.

In addition, shop-welded joints can be provided for longer pipe lengths when required. If it is necessary to field weld a joint, Thompson Pipe Group technical representatives should be consulted.

WELDED JOINT REPAIR (BOTH L-301 AND B-303)

Figure 20-1

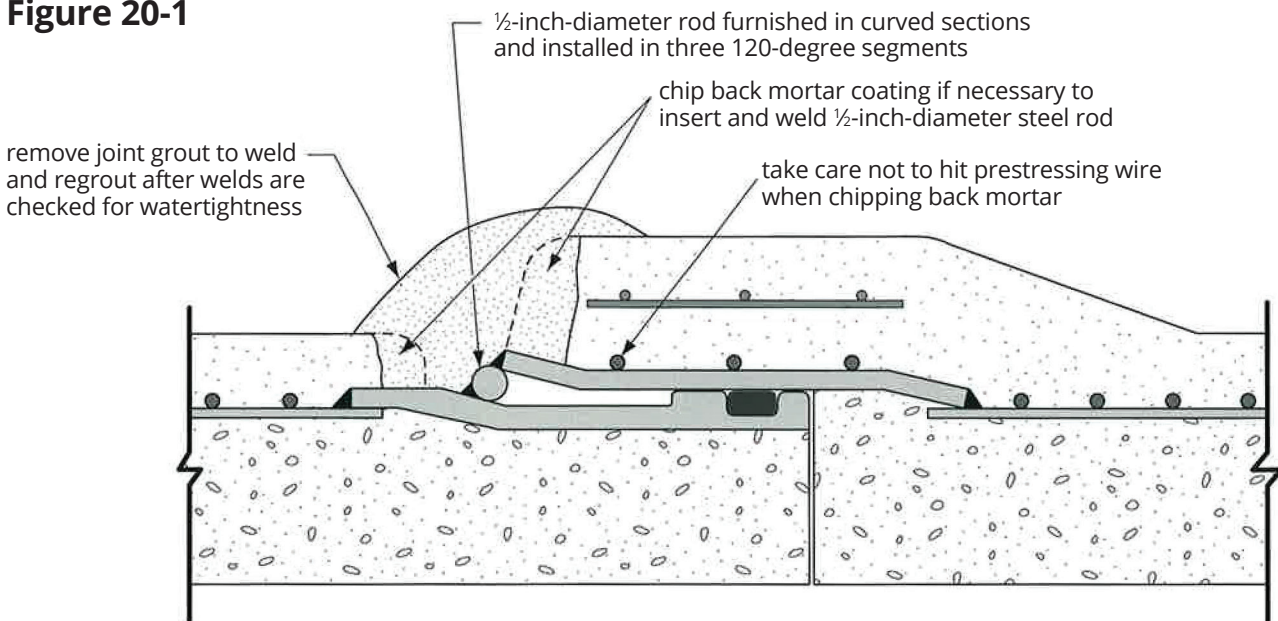

REPAIR SADDLES

If a prestressed concrete lined cylinder pipe becomes damaged in the field and the damage is confined to an area 12 inches in diameter or less, Thompson Pipe Group maintains a stock of saddles that can be utilized to repair the damaged pipe section. Special repair saddles for larger damaged areas on prestressed concrete lined cylinder pipe and for prestressed concrete embedded cylinder pipe can be manufactured at your request. Note this type of repair saddle can also be used on B-303 pipe. The saddles, in this case, must be specifically designed for use on B-303 pipe. Saddles for PCCP and B-303 are not interchangeable.

Figure 20-2

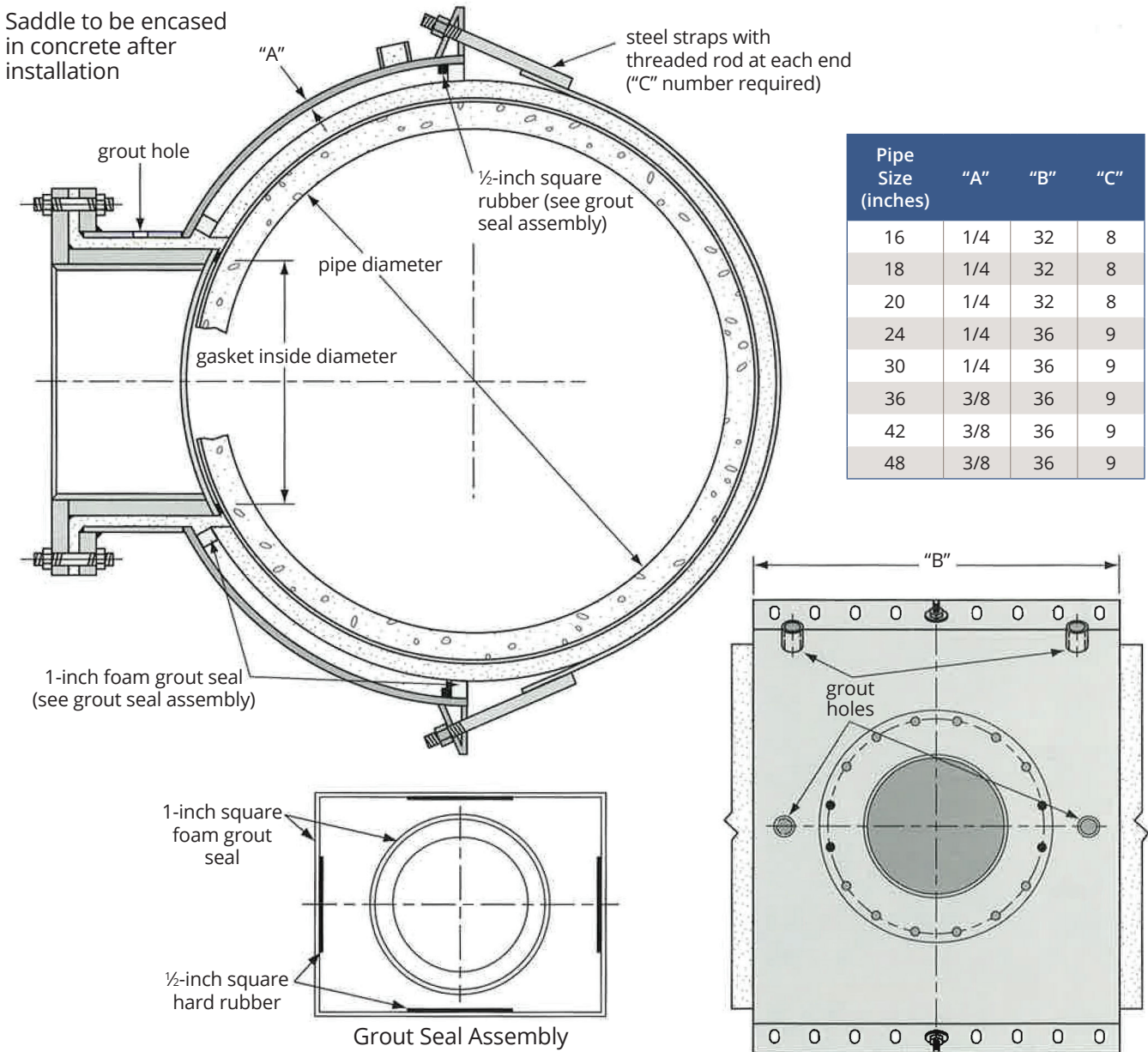

REPAIR SECTIONS

If the damage to an in-service pipe cannot be repaired by welding joints or by use of a repair saddle, the damaged section of pipe must be replaced. For example, the damaged pipe could be removed and replaced with a closure assembly package (Figure 20-3).

For further information on possible repair methods, refer to the Thompson Pipe Group Pipeline Services Repair Guide.

Figure 20-3

1. Measure clear space distance between joints of existing pipe.
2. Cut piece "C" to the required length.
3. Place piece "A" & "C" in the line; make up the joints in the normal manner.
4. Weld split butt-strap (piece "B") in place.
5. Make up inside pipe and closure gap with cement mortar (1" minimum)

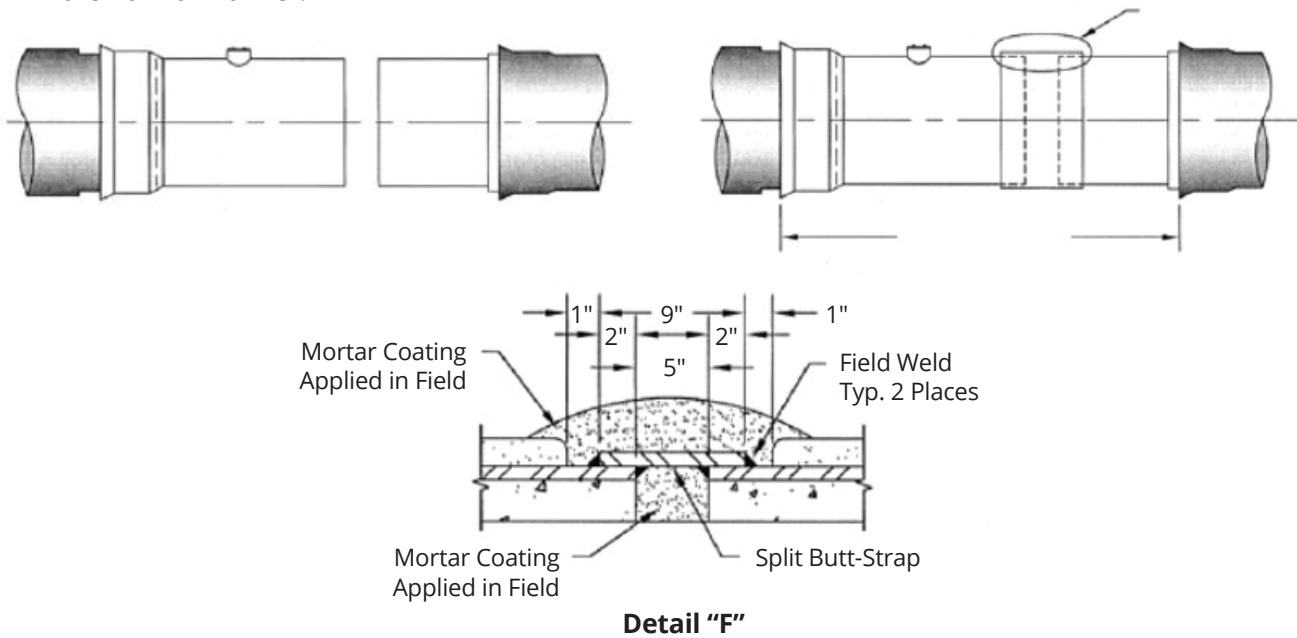

- A. Short piece with access
- B. Split butt-strap (two pieces)
- C. Short piece
- D. Access detail "D" -10" -18"; 1 req'd., 20" & 24"; 2 required.
- E. Access detail "E": 27" - 144"; 1 required.

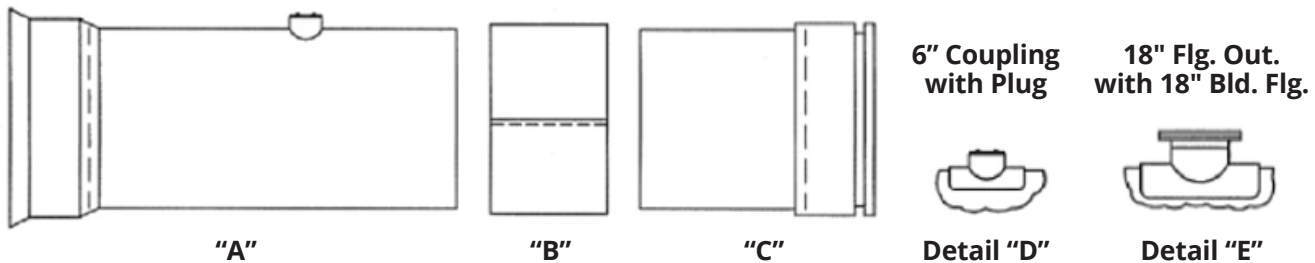

B-303 PIPE

Some repair methods for B-303 pipe, by its design, are applicable to only B-303 pipe. They would not be recommended for use with PCCP. One example would be repair of a small hole in the pipe caused by a directional drill or construction equipment impact. As can be seen in Figure 20-4, the reinforcing bars can be temporarily bent back out of the way and a small plate welded over the hole. After completion, the bars are bent back down onto the surface of the plate and welded. Portland cement-based patching material is then placed onto the area ensuring complete coverage of all exposed steel.

It's always recommended that Thompson Pipe Group be contacted regarding all planned repairs.

Figure 20-4

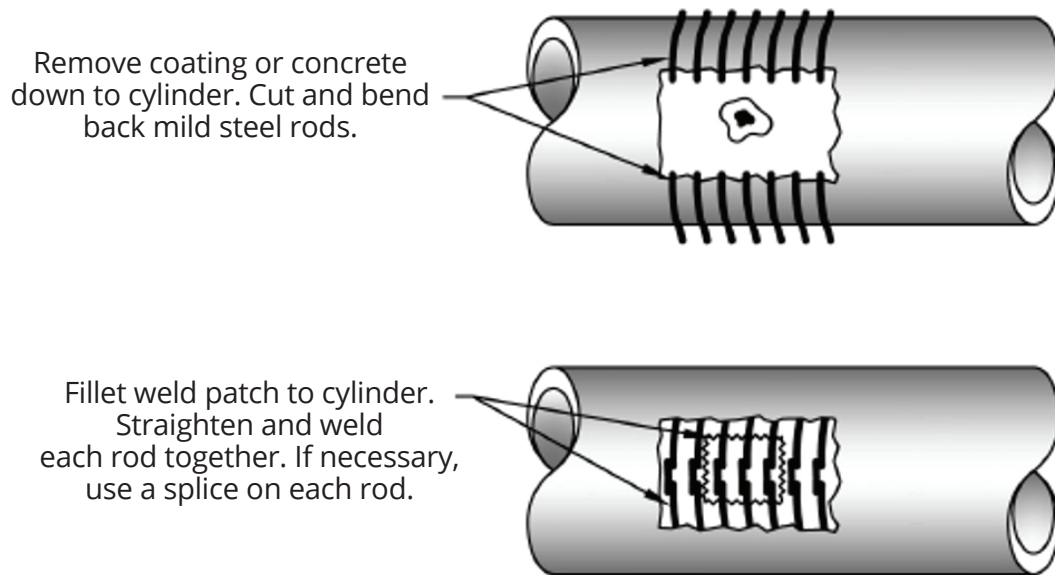



SECTION 21

APPENDIX

Standard Abbreviations Generally Used in the Laying Schedule and on Detail Drawings

ADPT	Adapter	FFE	From Flange End
AMJS	Anchored Mechanical Joint Spigot	FLG	Flange
AN	Anchored	FO	Flange Outlet
B or BOT	Bottom	FOLL/RING or FR....	Follower Ring
BA	Ball Joint	FSE	From Spigot End
BE	Bell End	FWJ	Field Welded Joint
BL	Bottom Left	G or GA	Cylinder Gauge
BR	Bottom Right	(H)	Horizontal
BEV	Beveled	HB	Half Bevel
BH	Bulkhead	HC	Harness Clamp Joint
BLD FLG	Blind Flange	HCB	Harnessed Carnegie Bell
BN	Bonded Joint	HCS	Harnessed Carnegie Spigot
BO	Blowoff	HHB	Heavy Harness Bell
CB	Carnegie Bell	HHC	Heavy Harness Clamp Joint
CIB	Cast Iron Bell	HHS	Heavy Harness Spigot
CIS	Cast Iron Spigot	HW	Heavy Wall Pipe
CL	Pipe Class	HW Bar	Hardway Bar
C/L	Centerline	ICTE	Interior Coal Tar Epoxy Paint
CLOS	Closure	ID	Inside Diameter
CONC	Concentric	ISC	Interior Seal Coat Paint
CS	Carnegie Spigot	INT	Interior
CTE	Coal Tar Epoxy	INV	Invert
C300	AWWA C300 Pipe	JT	Joint
C302	AWWA C302 Pipe	L	Left
D or DEG	Degrees	LCP	Lined Cylinder Pipe
DP	Deep Joint	LGTH	Length
DPB	Deep Carnegie Bell	LPE	Lugged Plain End
DPS	Deep Carnegie Spigot	LS	Long side
DWC	Double Wrap & Coat	LSB	Long Side Bottom
ECC	Eccentric	LSL	Long Side Left
ECP	Embedded Cyl Pipe	LSR.	Long Side Right
ECTE	Exterior Coal Tar Epoxy Paint	LST	Long Side Top
EDP	Extra Deep Joint	MC	Mechanical Coupling
EL or ELB	Elbow	MH	Manhole
EW BAR	Easyway Bar	MJB	Mechanical Joint Bell
EXT	Exterior	MJS	Mechanical Joint Spigot
FB	Full Bevel	MOCB	Mortared Over Carnegie Bell
FBE	From Bell End	MOCS	Mortared Over Carnegie Spigot

MTO	Mueller Threaded Outlet	SS	Short Side
MU	Mueller	STA	Station
NPTO	National Pipe Thread Outlet	STR	Straight (Standard Length Pipe)
OD	Outside Diameter	SUB	Subaqueous Joint
OJ	Open Joint	SWJ	Shop Welded Joint
OL	Outlet	T	Top
PE	Plain End	TL	Top Left
PL	Plate	TR	Top Right
PI	Point of Intersection	TAN	Tangent
PT	Paint	TBO	Tangent Blowoff
R	Right	TST	Testable Joint
RC	Raised Coating	TFO	Tangent Flange Outlet
RED	Reducer	(V)	Vertical
RFG	Rotate For Grade	VICT	Victaulic
RMC	Raised Mortar Coating Skids	WCB	Welded Carnegie Bell
SE	Spigot End	WCS	Welded Carnegie Spigot
SH	Short	WHE	Exterior White Epoxy Paint
SL	Springline	WP	Wallpiece
SR	Snap Ring® Joint	90TLK	90 Degree T-LOK
SRw/NB	Snap Ring® w/Nose Bar	180TLK	180 Degree T-LOK
SRB	Snap Ring® Bell	270TLK	270 Degree T-LOK
SRS	Snap Ring® Spigot	360TLK	360 Degree T-LOK

PIPE ORIENTATION

When standing at the spigot end of a pipe and looking at the bell end, the right side of the pipe is on the observer's right and the left side is on his left.

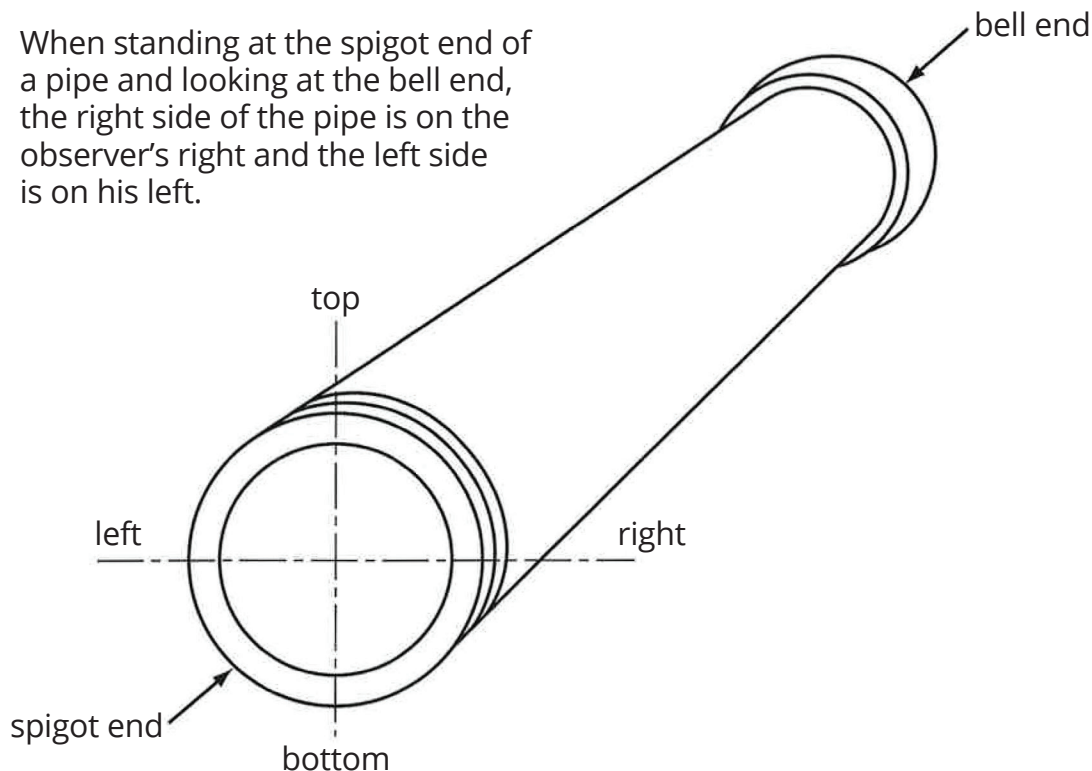

QUANTITIES OF JOINT LUBRICANT AND GROUT – STANDARD AND RESTRAINED JOINTS

Pipe Diameter (inches)	Approximate Number of Joints per 25 pounds of Lubricant	Approximate Amount of Grout per Standard Joint (cubic feet)	Approximate Amount of Grout per Restrained Joint (cubic feet)
16	100	0.35	0.70
18	87	0.40	0.80
20	75	0.42	0.84
24	50	0.57	1.14
30	45	0.71	1.42
36	40	0.85	1.70
42	35	1.22	2.44
48	30	1.37	2.74
54	25	1.62	3.24
60	20	1.75	3.50
66	19	1.95	3.90
72	18	2.12	4.24
78	17	2.38	4.76
84	15	2.66	5.32
90	14	2.91	5.82
96	12	3.11	6.22
102	9	3.37	6.74
108	9	3.48	6.96
114	9	3.71	7.42
120	8	3.97	7.94
126	8	4.14	8.30
132	7	4.33	8.66
138	7	4.49	9.00
144	6	4.67	9.34

CONVERSION FACTORS

The customary units of weight and mass as used in the United States are based on the English system of measurement and avoirdupois units unless otherwise designated.

The word gallon, used in any conversion factor, designates the U.S. gallon. To convert into the imperial gallon, multiply the U.S. Gallon by 0.83267. Likewise, the word "ton" designates a short ton, 2,000 pounds.

The figures 10^{-1} , 10^{-2} , 10^{-3} , etc. denote 0.1, 0.01, 0.001, etc. respectively. The figures 10^1 , 10^2 , 10^3 , etc. denote 10, 100, 1,000, etc. respectively.

In the conversion factors given below using the properties of water, calculations are based on water at 39.2 degrees Fahrenheit (4 degrees centigrade) in vacuum, weighing 62.427 pounds per cubic foot, or 8.345 pounds per U.S. gallon. Water freezes at 32 degrees Fahrenheit and is at its maximum density at 39.2 degrees Fahrenheit.

"Parts Per Million," designated as P.P.M., is always by weight. As used in the sanitary field, P.P.M. represents the number of pounds of dry solids contained in one million pounds of water, including solids. In this field, one part per million may be expressed as 8.345 pounds of dry solids to one million U.S. gallons of water.

ENGLISH CONVERSION FACTORS

Multiply	by	To obtain
Acres	43,560	Square feet
Acre-feet	43,560	Cubic feet
Acre-feet	3.259×10^5	Gallons
Atmospheres	29.92	Inches of mercury
Atmospheres	33.90	Feet of water
Atmospheres	14.70	Lbs./sq. Inch
Barrels cement	376	Pounds-cement
Bags or sacks-cement	94	Pounds-cement
B.T.U.	778.17	Foot-lbs.
B.T.U.	3.9301×10^{-4}	Horsepower-hrs.
B.T.U.	2.9306×10^{-4}	Kilowatt-hrs.
B.T.U./min.	12.970	Foot lbs./sec.
B.T.U./min.	0.023581	Horsepower
B.T.U./min.	0.017584	Kilowatts
Cubic feet	7.48052	Gallons
Cubic feet	1728	Cubic inches
Cubic feet	0.03704	Cubic yards
Cubic feet/second	0.646317	Million gals./day
Cubic feet/second	448.831	Gallons /min.
Cubic inches	5.787×10^{-4}	Cubic feet
Cubic inches	4.329×10^{-3}	Gallons
Cubic yards	27	Cubic feet
Cubic yards	46,656	Cubic inches
Cubic yards	202.0	Gallons
Drams	27.34375	Grains
Drams	0.0625	Ounces

Multiply	by	To obtain
Fathoms	6	Feet
Feet of water	0.8826	Inches of mercury
Feet of water	0.4335	Lbs./sq. inch
Feet of water	62.427	Lbs./sq. feet
Feet of water	0.02950	Atmospheres
Foot-pounds	1.285×10^{-3}	B.T.U.
Foot-pounds	5.0505×10^{-7}	Horsepower-hrs.
Foot-pounds	3.766×10^{-7}	Kilowatt-hrs.
Foot-pounds/min.	3.0303×10^{-5}	Horsepower
Foot-pounds/min.	2.260×10^{-5}	Kilowatts
Gallons	0.13368	Cubic feet
Gallons	231	Cubic inches
Gallons, Imperial	1.20095	U.S. gallons
Gallons, U.S.	0.83267	Imperial gallons
Gallons water (at 4° C)	8.3453	Pounds of water
Gallons water (at 62° F)	8.3355	Pounds of water
Gallons/min	2.228×10^{-3}	Cubic feet/sec.
Gallons/min	8.0208	Cu. ft./h.r
Grains (troy)	1	Grains (avdp.)
Grains (troy)	0.06480	Grams
Grains/U.S. gal.	17.119	Parts/million
Grains/U.S. gal.	142.86	Lbs./million gal.
Grains/Imp. gal.	14.286	Parts/million
Hectares	2.471	Acres
Horsepower	42.44	B.T.U./min.
Horsepower	550	Foot-lbs./sec.
Horsepower	0.7457	Kilowatts
Horsepower (boiler)	33.520	B.T.U./hr.
Horsepower (boiler)	9.803	Kilowatts
Inches of mercury	1.133	Feet of water
Inches of mercury	0.4912	Lbs./sq. inch
Inches of mercury	0.03342	Atmospheres
Inches of water	0.07355	Inches of mercury
Inches of water	0.03613	Lbs./sq. inch
Kilowatts	56.92	B.T.U./min.
Kilowatts	737.5	Foot/lbs./sec.
Kilowatts	1.341	Horsepower
Miles	5280	Feet
Miles/min.	88	Feet/sec.
Million gals./day	1.54723	Cubic ft./sec.
Miner's inches	1.5	Cubic ft./min.
Ounces	437.5	Grains
Ounces	0.9115	Ounces (troy)
Ounces (fluid)	1.805	Cubic inches
Parts/million	8.345	Lbs./million gal
Parts/million	0.058415	Grains/U.S. gal
Parts/million	0.07016	Grains/Imp. gal
Pounds	16	Ounces
Pounds	7000	Grains

Multiply	by	To obtain
Pounds	1.21528	Pounds (troy)
Pounds of water	0.01602	Cubic feet
Pounds of water	27.68	Cubic inches
Pounds of water	0.1198	Gallons
Pounds/cubic foot	5.787×10^{-4}	Lbs./cubic inch
Pounds/sq. foot	0.01602	Feet of water
Pounds/sq. inch	2.307	Feet of water
Pounds/sq. inch	2.0358	Inches of mercury
Pounds/sq.inch	0.06803	Atmospheres
Quires	25	Sheets
Reams.	500	Sheets
Square feet	144	Square inches
Square feet	2.296×10^{-5}	Acres
Square miles	640	Acres
Square miles	2.788×10^7	Square feet
Square yards	9	Square feet
Square yards	2.066×10^{-4}	Acres
Tons (long).	2240	Pounds
Tons (long).	1.12	Tons (short)
Tons (short)	2000	Pounds
Tons of water/24 hrs	0.16643	Gallons/min.
Watts	0.05686	B.T.U./min.
Watts	0.7375	Foot-pounds/sec.
Watts	1.341×10^{-3}	Horsepower

METRIC CONVERSION FACTORS

Multiply	by	To obtain
Acres	4047	Square meters
Acre-feet	1233.5	Cubic meters
Atmosphere	1.01325	Bars
Atmospheres	76.0	Centimeters of mercury
Bars	0.98692	Atmosphere
Bars	1.02×10^4	Kgs./sq. meter
Bars	14.50777	Lbs./sq. in.
Bars	100	Kilopascals
Bars	33.46	Feet of water
B.T.U.	0.2520	Kilogram calories
B.T.U.	107.6	Kilogram meters
Centimeter.	0.3937	Inches
Centimeters of mercury	0.01316	Atmospheres
Centimeters of mercury	0.4461	Feet of water
Centimeters of mercury	27.85	Lbs./sq. f.t
Centimeters of mercury	0.1934	Lbs./sq. in.
Centimeters/second	1.969	Feet/minute
Centimeters/second	0.03281	Feet/sec.
Centimeters/second	0.6	Meters/min.

Multiply	by	To obtain
Cubic centimeters	3.531×10^{-5}	Cubic feet
Cubic centimeters	0.06102	Cubic inches
Cubic centimeters	2.642×10^{-4}	Gallons
Cubic centimeters	1.0×10^{-6}	Cubic meters
Cubic centimeters	1.0×10^{-3}	Liters
Cubic feet	28.32	Liters
Cubic feet	2.832×10^4	Cubic centimeters
Cubic feet	0.02832	Cubic meters
Cubic inches	16.39	Cubic centimeters
Cubic inches	1.639×10^{-5}	Cubic meters
Cubic inches	0.01639	Liters
Cubic meters	35.31	Cubic feet
Cubic meters	1.308	Cubic yards
Cubic meters	264.2	Gallons
Cubic meters	1.0×10^3	Liters
Cubic yards	0.7646	Cubic meters
Cubic yards	764.6	Liters
Dram	1.771845	Grams
Feet	30.48	Centimeters
Feet	0.3048	Meters
Feet of water	304.8	Kgs./sq. meter
Feet/sec./sec	0.3048	Meters/sec./sec.
Feet/sec	30.48	Centimeters/sec.
Feet/sec	18.29	Meters/minute
Foot-pounds	0.1383	Kilogram-meters
Gallons	3785	Cubic centimeters
Gallons	3.785×10^{-3}	Cubic meters
Gallons	3.785	Liters
Gallons/minute	0.06308	Liters/second
Gallons/minute	6.308×10^{-5}	Cubic meters/sec.
Grams	15.432	Grains (troy)
Grams	0.03527	Ounces (avdp.)
Grams	980.7	Dynes
Grams/sq. centimeter	0.9808×10^3	Bars
Grams/liter	58.417	Grains/gal.
Grams/liter	8.344	Pounds/1000 gallons
Grams/liter	1000	Parts/million
Grams/cubic centimeter	1000	Kilograms/cubic meter
Inches	2.540	Centimeters
Inches of mercury	345.3	Kgs./sq. meter
Inches/second	0.0254	Meters/second
Inches/sec./sec.	0.0254	Meters/sec./sec.
Kilograms	2.2046	Pounds
Kilogram/calories/minute	51.43	Foot-pounds/sec.
Kilogram-calories/minute	0.06972	Kilowatts
Kilogram-calories/minute	0.09351	Horsepower
Kilograms/sq. meter	1.422×10^{-3}	Pounds/sq. inch
Kilometers	3281	Feet
Kilometers	0.6214	Miles

Multiply	by	To obtain
Kilometers/hour	0.9113	Feet/sec.
Kilometers/hour	27.78	Centimeters/sec.
Kilowatts	14.33	Kilogram-calories/minute
Liters	0.2642	Gallons
Liters	61.02	Cubic inches
Liters	0.03531	Cubic feet
Meters	3.281	Feet
Meters	39.37	Inches
Meters	1.094	Yards
Miles	1.609	Kilometers
Miles/minute	1.609	Kilometer/minute
Milligrams/liter	1	Parts/million
Ounces	28.3495	Grams
Ounces (fluid)	29.58	Cubic centimeters
Pounds	453.5924	Grams
Pounds/cubic foot	0.01602	Grams/cubic centimeter
Pounds/cubic foot	16.02	Kilograms/cubicmeter
Pounds/foot	1.488	Kilograms/meter
Pounds/inch	178.6	Grams/centimeter
Pounds/sq. foot	4.883	Kilograms/sq. meter
Pounds/sq. inch	703.1	Kilograms/sq. meter
Pounds/sq. inch	6895	Pascals
Pounds/sq. inch	0.07031	Kilograms/sq. centimeter
Megapascals	145	Pounds/sq. inch
Pascal	1.45×10^{-4}	Pounds/sq. inch
Square centimeters	0.1550	Square inches
Square centimeters	1.076×10^{-3}	Square feet
Square feet	0.09290	Square meters
Square inches	6.452	Square centimeters
Square kilometers	247.1	Acres
Square kilometers	1.076×10^7	Square feet
Square kilometers	1.196×10^6	Square yards
Square meters	10.76	Square feet
Square meters	1.196	Square yards
Square miles	2.590	Square kilometers
Square yards	0.8361	Square meters
Tons (long)	1016	Kilograms
Tonnes (metric)	10×10^3	Kilograms
Tonnes (metric)	2205	Pounds
Tons (short)	907.185	Kilograms
Watts	0.01433	Kilogram-calories/minute
Yards	0.9144	Meters



INDEX

A

Access manholes	6.3
Acid soils	16.7
Adapters	Section Ten
bevel	10.4
flange	10.1
mechanical joint	10.2
Carnegie joint	10.4
Victaulic	10.3
Adverse environments	Section Sixteen
Aerial installation	14.3
Allowable soil pressures	13.2
American Water Works Association	
AWWA Standard C301	1.1
AWWA Standard C304	1.1
AWWA Manual M9	13.2
AWWA Standard C300	3.1
Anchor ring pipe	13.8
Appendix	Section Twenty-One
conversion factors	21.4
pipe orientation	21.2
quantities joint lubricant and grout	21.3
standard abbreviations	21.1
Atmospheric exposure	16.8

B

Ball joints	4.11
Bar-wrapped pipe	3.9
Bedding and Backfill	PCCP Design Guide
Bevels.	5.1
half bevel pipe	5.6
full bevel pipe	5.5
Bevel adapters	10.4
Blowoff outlets	6.1
Bonded joints	4.8
exothermic fusion weld	4.8
U-clip type	4.10

Bonding	4.8, 16.9
Bulkheads.	11.1
dished type	11.1
flat plate type	11.3
night caps/ plugs	12.2
thrust restraint	13.6
Buoyancy	14.1

C

Carbonation	16.7
Cathodic protection	16.10
Chloride soils	16.5
Closures	
follower ring	11.8
welded	11.8
Coatings and linings	
exterior	17.1, 17.2
interior	17.2
Coefficient of friction	13.5
Combined elbows	7.2
Concentric reducers	9.1
Concrete	
casting	2.2
core	2.2
curing	2.2
testing	2.2, 2.5
Connections to other pipelines.	16.9
Construction loads	PCCP Design Guide
Conversion factors	21.4
Crane loads	PCCP Design Guide
Crosses	8.1
Custom fittings	11.11
Cylinder thicknesses	
elbows	7.4
reducers	9.2
tees	8.5

D	
Deep joints	4.2
deflection table	5.2
Deflection	5.1
Deflection tables	
bevel adapters	10.4
deep joints	5.3
extra deep joints	5.7
full bevel joints	5.5
half bevel joints	5.6
standard joints	5.4
Design	Section Twelve
bedding and backfill	PCCP Design Guide
construction loads	PCCP Design Guide
crane loads	PCCP Design Guide
pipe design sheet sample	18.5
external loads	PCCP Design Guide
footer loads	PCCP Design Guide
hydraulics	12.6
pile support	14.3
thrust loads	Section Thirteen
train loads	PCCP Design Guide
truck loads	PCCP Design Guide
Double wrapped and coated pipe	14.1
Drawings	
detail	18.5
line	18.4
E	
Eccentric reducers	9.1
Elbows	Section Seven
cylinder thickness	7.4
laying lengths	7.3
rotation and combined	7.2
thrust restraint	Section Thirteen
Embedded cylinder pipe	3.5
deflection	
bevel adapters	10.4
deep joints	5.3
full bevel joints	5.5
half bevel joints	5.6
standard joints	5.4
manufacturing	2.1
outlet laying lengths	Section Six
subaqueous joint	4.8
testable joint	4.6
Environment	Section Sixteen
pipeline protection	16.5
external protection guidelines summary ...	16.9
soil types	16.1
Epoxy paint	17.1
External loads	PCCP Design Guide
Extra deep joints	4.12
deflection	5.7
F	
Field services	20.1
Fittings	2.4
Flanges	11.5
Flotation (buoyancy)	14.1
Flow chart for manufacturing	2.1
Flow equations, hydraulics	12.6
Follower ring closure	11.8
Footer loads	PCCP Design Guide
Friction losses, hydraulics	12.6
Frictional resistance, thrust	13.5
G	
Galvanic series	16.8
Grout quantities for pipe joints	22.3
Guidelines to protect PCCP in adverse environments	16.9
H	
Harness clamps	4.4
Hazen-Williams equation for head loss	12.5
Head loss	12.7
Heavy wall pipe	14.1
History	1.1
Horizontal curve restraint	13.3, 13.4
Hydraulics	12.6
Hydrodynamic force	13.1
Hydrostatic force	13.1
Hydrostatic testing	
pipe cylinder	2.1
completed pipeline	20.3, 20.6

I	
Inspection	2.5
Intakes	
specification	19.1
Internal pressure	PCCP Design Guide
surge	PCCP Design Guide
working	PCCP Design Guide
Introduction to prestressed	
concrete pressure pipe	Section One

J	
Jacking pipe	14.6
Joints	
deflection (see deflection tables)	
depth	5.2, 5.3
diameter	5.2, 5.3
flexibility	4.12
grout	21.3
lubricant	21.3
restrained	4.3, 4.4
Joint types	
ball joint.	4.11
bonded	4.8, 4.9
deep	4.2
extra deep	4.12
flange	21.3
harness clamp	4.4
mechanical joint	11.4
plain end	11.10
Snap Ring®	4.3
standard	4.1
steel	10.2
subaqueous	4.8
testable	4.6
Victaulic	10.3
welded	13.7
zinc metalizing	4.13

L	
Laying lengths	
adapters	Section Ten
bevels	5.5, 5.6
elbows	7.3
embedded cylinder pipe	3.4
end connections	Section Eleven

laying schedule sample	18.2
lined cylinder pipe	3.2
reducers	Section Nine
tees	8.3
wyes	8.7, 8.8
Layout	Section Eighteen
abbreviations used	21.1
design sheet	18.4
laying schedule	18.3
line drawing	18.5
material list	18.6
typical detail drawing	18.5
Lewistown Pipe Company	1.1
Line drawing sample	18.5
Lined cylinder pipe	3.2
deflection	
bevel adapters	10.4
deep joints	5.3
extra deep joints	5.7
full bevel	5.5
half bevel	5.6
manufacturing	2.1
outlet laying lengths	Section Six
subaqueous	4.7
Linings, protective	17.2
Loads	PCCP Design Guide
construction	PCCP Design Guide
crane	PCCP Design Guide
external	PCCP Design Guide
footer	PCCP Design Guide
train	PCCP Design Guide
truck	PCCP Design Guide
Lubricant, joint	
quantities	21.3

M	
Manholes, access	6.3
Manufacturing	
embedded cylinder pipe	2.2
fittings	2.4
flow chart	2.1
lined cylinder pipe	2.2
Material shipping list	18.6
Mechanical joints	11.4

Miscellaneous fittings	Section Eleven
Moisture and free oxygen levels	16.3
Moisture table	16.4
Monitoring, pipeline	16.9
Mortar coating	2.3

N

Night caps/plugs	11.2
Nomograph for flow	12.8
Non-float pipe	14.1

O

Orientation of pipe	21.2
Outfalls	14.2
Outlet laying lengths	Section Six
Outlet pipe	
access manholes	6.3
centerline	6.4
flange	6.4, 6.5
mechanical joint	6.4, 6.5
reinforcing bands	6.11, 6.12
tangent	6.5
threaded	6.2

P

Painting Pipe	17.1, 17.2
PCCP Design Guide	Section Thirteen
Pedalfer soils	16.1
Pedocal soils	16.1
Pile supported pipe	14.3
Pipeline environment	Section Sixteen
Pipeline materials	16.5
Pipe orientation	21.2
Pipe weights	3.2, 3.3
Plain ends	11.10
Polyethylene encasement	17.2
Prestressing wire	2.5

Q

Quality assurance	2.5
-----------------------------	-----

R

Reducers	
concentric	9.1
cylinder thickness	9.2
eccentric	9.1
thrust restraint	13.6
Reinforcing bands, outlets	6.11, 6.12
Repair saddles	20.2
Restrained joints	
anchor ring	13.6
harness clamp	4.4
restrained distance calculations	13.9
Snap Ring®	4.3
welded	13.7
River crossings	14.2

S

Saddles	
repair	20.2
tapping	15.1
Short pipe	3.1
Slurry	2.3
Snap Ring® joint	4.3
Soil pressure table	13.2
Soil types	
pedalfers	16.1
pedocals	16.1
Special applications	Fourteen
Standard joint	4.1
Standard pipe	
deflection	5.2
embedded cylinder pipe	3.5
lined cylinder pipe	3.3
Steel cylinder	2.1
Stray current interference	16.6
Subaqueous joints	
embedded cylinder	4.8
lined cylinder	4.8
Subaqueous installation	14.2
Sulfate soils	16.5
Supplemental protection	
for PCCP	Section Eighteen

T

Tangent outlets	6.5
laying lengths	6.6
Tapping	
flanged type	15.3
small diameter strap type	15.2
Tees	
laying lengths	8.4
cylinder thickness	8.5
with crotch plates	8.1
without crotch plates	8.2
Testable joint	4.6
Tests	
hydrostatic (manufacturing)	2.1
quality assurance	2.5
Threaded outlets	6.2
Thrust	
at bulkheads	13.3
at elbows	13.4
at reducers	13.4
at tees	13.4
blocks	13.1
large deflection	13.2
restrained joints	13.7
restraining	13.1
sample calculations	13.3
small deflection	13.1
Train loads	PCCP Design Guide
Treatment plant piping	14.6
Truck loads	PCCP Design Guide
Tunnel installations	14.3
Tunneling methods	14.3

U

Underwater installation	14.2
-------------------------------	------

V

Vertical curve restraint	13.1
Vertical wrapping machine	2.3
Victaulic adapters	10.3
end details	11.8

W

Wall pieces	11.4
dimensions	11.7
full wall penetration	11.4
joints both faces	11.6
partial penetration	11.5
Wall thicknesses (pipe)	
embedded cylinder pipe	3.4
lined cylinder pipe	3.2
Water table	16.4
Weight of pipe	3.2, 3.3
Welded closure	11.18
Welded joints	20.1
Wyes	
laying lengths	8.7

Z

Zinc Metalizing	4.13
-----------------------	------