



Flowtite

Installation Guide Above Ground with non-restrained Joints



AMIATIT PIPE SYSTEMS

1 Introductory Information 3

1.1 Foreword 3

1.2 Introduction 3

1.3 Field Technician 3

1.4 Fire Safety 3

2 Shipping, Handling and Storage 4

2.1 Inspecting Pipe 4

2.2 Repairing Pipe 4

2.3 Unloading and Handling Pipe 4

2.4 Site Pipe Storage 5

2.5 Storing Gaskets and Lubricant 5

2.6 Transporting Pipe 6

2.7 Handling Nested Pipes 6

3 Joining Pipes 7

3.1 FLOWTITE Double Bell Couplings 7

3.2 Other Coupling Joints 11

3.3 Flanged Joints Contact Moulded 12

4 Installation of Aboveground Pipes 14

4.1 Introduction 14

4.2 Supporting of Pipes 14

4.3 Maximum Supporting Spacing 22

4.4 Negative Pressure 22

5 Checking the Installed Pipe 24

5.1 Field Hydrotesting 24

5.2 Inspection Prior to Filling of Pipe 24

5.3 Inspection of Filled Pipeline Prior to Pressurizing 25

5.4 Inspection of Pressurized Pipelines 25

6 Thrust Restraints, Concrete Encasement and Rigid Connections Structure 26

6.1 Thrust Restraints 26

6.2 Concrete Encasement 27

6.3 Rigid Connections 28

6.4 Casings (Tunnels) 29

7 Field Adjustments 30

7.1 Length Adjustment 30

7.2 Field Closures with FLOWTITE 30

7.3 Field Closures width Non-FLOWTITE Couplings 31

Appendices 32

A. Approximate Weights for Pipes and Couplings 32

B. Joint Lubricant Requirements 33

1 Introductory Information

01

02

03

04

05

06

07

app.

1.1 Foreword

This manual is intended to assist the installer in understanding the requirements and procedures for the successful handling and installation of FLOWTITE pipes above ground. It applies for pipes joined by non-restrained couplings as the double bell FLOWTITE coupling or flexible steel couplings. It may also be a helpful source of data for project engineers, although it is not a design guide or system engineering manual.

We have tried to address the unusual, as well as usual, circumstances that may be encountered in the field; however, it is certain that unique situations requiring special consideration will occur. When this happens, ask the supplier for help.

Also, installations other than aboveground on cradles, such as direct bury or subaqueous are not discussed herein. For direct bury use "Flowtite Installation Guide for Buried Pipes". Otherwise, consult the supplier for suggested procedures and limitations in these cases. Most importantly, this booklet is not meant to replace common sense, good engineering judgement, safety regulations, local ordinances or the specifications and instructions of the owners engineers who is the final authority on all jobs. Should conflicts in any of this information arise that create doubts as how to proceed properly, please consult the supplier and the owner's engineer to obtain assistance.

1.2 Introduction

The excellent corrosion resistance and many other benefits of FLOWTITE pipe can be realized if the pipe is properly installed. FLOWTITE pipe is designed considering the support that will result from these recommended installation procedures. FLOWTITE Pipe Systems generally recommends the use of standard SN5000 pipes for aboveground pipe installations. The recommended installation procedures are therefore based on the application of standard SN5000 pipes. The procedures also apply for pipes with higher stiffness, i.e. SN10000. Aboveground installation of pipes with stiffness lower than SN5000 requires special consideration. The installation procedures outlined in this brochure and the suggestions of the Field Service Representatives, when carefully followed, will help assure a proper, long-lasting installation. Consult the supplier on any questions or when variations in these instructions are being considered.

1.3 Field Technician

The supplier can, at the request of the purchaser and within the terms of the agreement between the purchaser and the supplier, provide a Field Technician. The Field Technician can advise the purchaser and/or the Installer to help him achieve a satisfactory pipe installation. It is recommended that "on the job" field service should be engaged in the initial stage of installation and may continue periodically throughout the project. The service may range from continuous (essentially full time) to intermittent depending on agreement between purchaser and supplier.

1.4 Fire Safety

Glass-reinforced polyester (GRP) pipe, like virtually all pipe made with petrochemicals, can burn and is, therefore, not recommended for use in applications which are exposed to intense heat or flames. During installation, care must be taken to avoid exposure of the pipe to welder's sparks, cutting-torch flames or other heat/flame/electrical sources which could ignite the pipe material. This precaution is particularly important when working with volatile chemicals in making layup joints, repairing or modifying the pipe in the field.

2 Shipping, Handling and Storage

2.1 Inspecting Pipe

All pipes should be inspected upon receipt at the job site to insure that no damage has occurred in transit. Depending on length of storage, amount of job site handling and other factors that may influence the pipes condition, it is recommended that the pipe be re-inspected just prior to installation. Inspect the shipment upon delivery, as follows:

- 1 Make an overall inspection of the load. If the load is intact, ordinary inspection while unloading will normally be sufficient to make sure the pipe has arrived without damage.
- 2 If the load has shifted or indicates rough treatment, carefully inspect each pipe section for damage. Generally, an exterior inspection will be sufficient to detect any damage. When pipe size permits, an interior inspection of the pipe surface at the location of an exterior scrape may be helpful to determine if the pipe is damaged.
- 3 Check the quantity of each item against the bill of lading.
- 4 Note on the bill of lading any transit damage or loss and have the carrier representative sign your copy of the receipt. Claims against the carrier should be in accordance with their instructions.
- 5 If any imperfections or damage is found, segregate the affected pipes and contact the supplier.

Do not use pipe that appears damaged or defective.

2.2 Repairing Pipe

Normally, pipes with minor damage can be repaired quickly and easily at the job site by a qualified individual. If in doubt about the condition of a pipe, do not use it.

The Field Technician can help you determine whether repair is required and whether it is possible and practical. Repair designs can vary greatly due to pipe thickness, wall composition, application, and the type and extent of the damage. Therefore do not attempt to repair a damaged pipe without consulting the supplier first. Repairs must be made by a trained repair technician. Improperly repaired pipes may not perform as intended.

2.3 Unloading and Handling Pipe

Unloading the pipe is the responsibility of the customer. Be sure to maintain control of the pipe during unloading. Guide ropes attached to pipes or packages will enable easy manual control when lifting and handling. Spreader bars may be used when multiple support locations are necessary. Do not drop, impact, or bump the pipe, particularly at pipe ends.

Single Pipes

When handling single pipes, use pliable straps, slings or rope to lift. Do not use steel cables or chains to lift or transport the pipe. Pipe sections can be lifted with only one support point (**Figure 2-1**) although two support points placed as in **Figure 2-2** is the preferred method for safety reasons as it makes the pipe easier to control. Do not lift pipes using hooks at pipe ends or by passing a rope, chain or cable through the section end to end. See Appendix A for approximate weights of standard pipes and couplings.

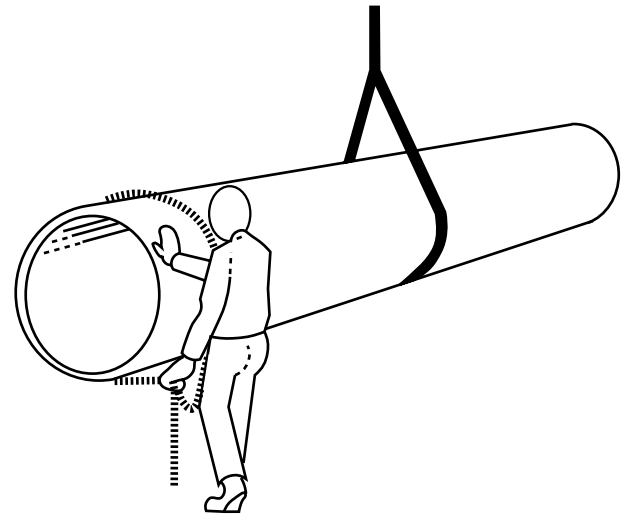

Figure 2-1 Lifting pipe at one support point

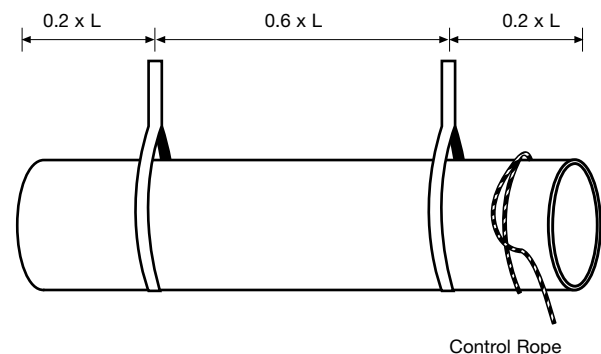

Figure 2-2 Lifting pipe at two support points

Unitized Loads

Unitized loads may be handled using a pair of slings as shown in **Figure 2-3**. Do not lift a non-unitized stack of pipes as a single bundle. Non-unitized pipes must be unloaded and handled separately (one at a time).

If at any time during handling or installation of the pipe, any damage such as a gouge, crack or fracture occurs, the pipe should be repaired before the section is installed.

Contact the supplier for inspection of damaged and for recommendation of repair method or disposal. See **Section 2.2** →.

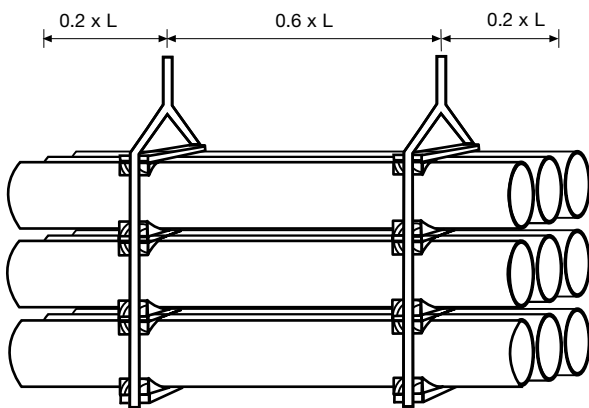

Figure 2-3 Lifting unitized package

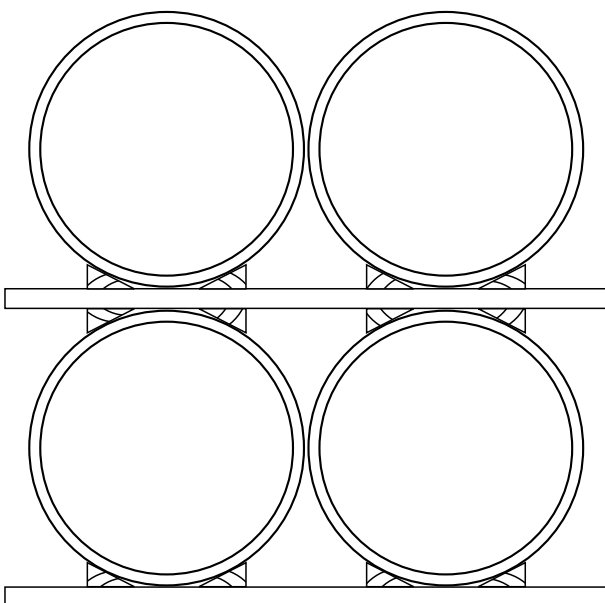

Figure 2-4 Storing pipe

2.4 Site Pipe Storage

It is generally advantageous to store pipe on flat timber to facilitate placement and removal of lifting slings around the pipe.

When storing pipe directly on the ground, be sure that the area is relatively flat and free of rocks and other potentially damaging debris. Placing the pipe on mounds of backfill material has been found to be an effective way of site storing the pipe. All pipes should be chocked to prevent rolling in high winds.

If it is necessary to stack pipes, it is best to stack on flat timber supports (minimum width of 75 mm) at quarter point with chocks (**see Figure 2-4**). If it is available, use the original shipping dunnage.

Insure the stack will be stable for conditions such as high winds, uneven storage surface or other horizontal loads.

If strong winds are anticipated consider using ropes or slings to tie pipes down. Maximum stack height is approximately 3 metres.

Bulges, flat areas or other abrupt changes of pipe curvature are not permitted. Storing of pipes outside of these limitations may result in damage to the pipes.

2.5 Storing Gaskets and Lubricant

Rubber ring gaskets, when shipped separately from the couplings, should be stored in the shade in their original packing and should not be exposed to sunlight except during the pipe joining. Also, the gaskets must be protected from exposure to greases and oils which are petroleum derivatives, and from solvents and other harmful substances.

Gasket lubricant should be carefully stored to prevent damage. Partially used buckets should be resealed to prevent contamination of the lubricant. If temperatures during installation are below 5° C, gaskets and lubricant should be sheltered until used.

2.6 Transporting Pipe

Support all pipe sections on flat timbers, spaced at maximum 4 metres with a maximum overhang of 2 metres. Chock the pipes to maintain stability and separation. Avoid abrasion.

Maximum stack height is approximately 2.5 metres. Strap pipe to the vehicle over the support points using pliable straps or rope (**Figure 2-5**). Never use steel cables or chains without adequate padding to protect the pipe from abrasion. Bulges, flat areas or other abrupt changes of curvature are not permitted. Transport of pipes outside of these limitations may result in damage to the pipes.

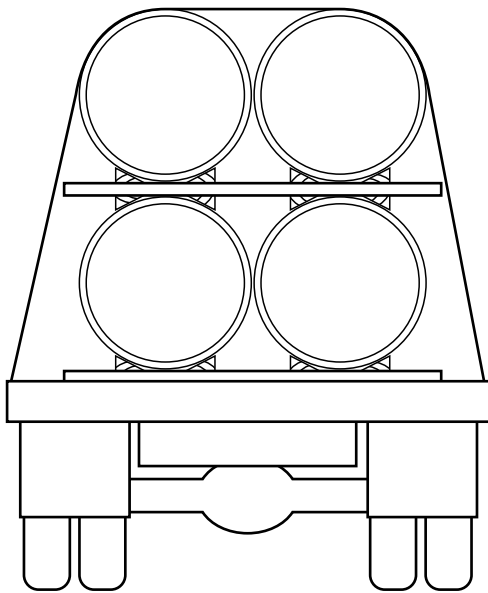

Figure 2-5 Transporting pipe

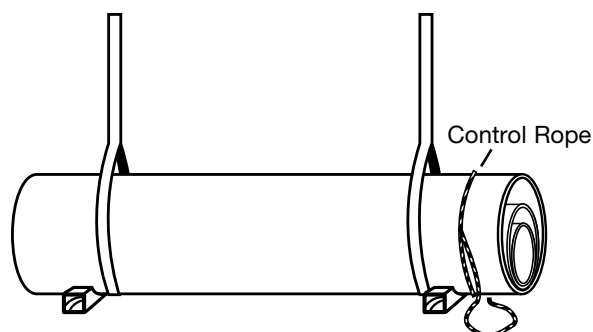

Figure 2-6 Double support point for nested pipes

2.7 Handling Nested Pipes

Pipes may be nested (smaller diameter pipes inside of larger sizes). These pipes generally have special packaging and may require special procedures for unloading, handling, storing and transporting. Special measures, if required, will be carried out by the pipe supplier prior to shipment. However, the following general procedures should always be followed:

- 1** Always lift the nested bundle using at least two pliable straps (**Figure 2-6**). Limitations, if any, for spacing between straps and lifting locations will be specified for each project. Insure that the lifting slings have sufficient capacity for the bundle weight. This may be calculated from the approximate pipe weights given in Appendix H.
- 2** Nested pipes are usually best stored in the transport packaging. Stacking of these packages is not advised unless otherwise specified.
- 3** Nested pipe bundles can only be safely transported in the original transport packaging. Special requirements, if any, for support, configuration and/or strapping to the vehicle will be specified for each project.
- 4** Package removal and de-nesting of the inside pipe(s) is best accomplished at a de-nesting station. Inside pipes, starting with the smallest size may be removed by lifting slightly with an inserted padded boom to suspend the section and carefully move it out of the bundle without damaging the other pipes (**Figure 2-7**). When weight, length and/or equipment limitations preclude the use of this method, procedures for sliding the inside pipe(s) out of the bundle will be recommended for each project.

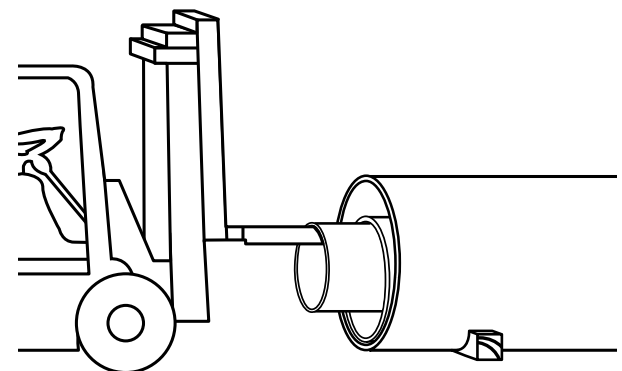

Figure 2-7 De-nesting with padded boom on forklift truck

3 Joining Pipes

01
02
03
04
05
06
07
app.

FLOWTITE pipe sections are typically joined using FLOWTITE couplings. Pipe and couplings may be supplied separately or the pipe may be supplied with a coupling installed on one end. If the couplings are not delivered pre-mounted, it is recommended that they be mounted at the storage yard or at the building site before the pipe is mounted on the supports.

Other joining system such as flanges, mechanical couplings and lay-up joints may also be used for joining FLOWTITE pipes.

3.1 FLOWTITE double Bell Couplings

The following steps (1-4) are meant for FLOWTITE Pressure Couplings.

Step 1 Cleaning Coupling

Thoroughly clean double bell coupling grooves and rubber gasket rings to make sure no dirt or oil is present (Figure 3-1).

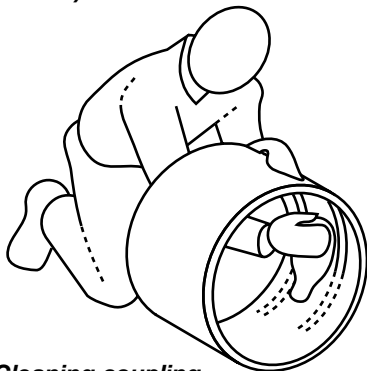

Figure 3-1 Cleaning coupling

Step 2 Install Gaskets

Insert the gasket into the groove leaving loops (typically two to four) of rubber extending out of the groove. Do not use any lubricant in the groove or on the gasket at this stage of assembly. Water may be used to moisten the gasket and groove to ease positioning and insertion of the gasket (Figure 3-2).

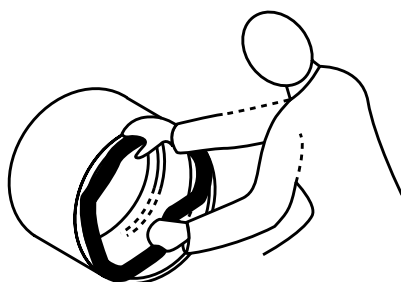

Figure 3-2 Installing gasket

With uniform pressure, push each loop of the rubber gasket into the gasket groove. When installed, pull carefully in the radial direction around the circumference to distribute compression of the gasket. Check also that both sides of the gasket protrude equally above the top of the groove around the whole circumference. Tapping with a rubber mallet will be helpful to accomplish the above.

Step 3 Lubricate Gaskets

Next, apply a thin layer of lubricant to the rubber gaskets (Figure 3-3). See Appendix I for normal amount of lubricant consumed per joint →.

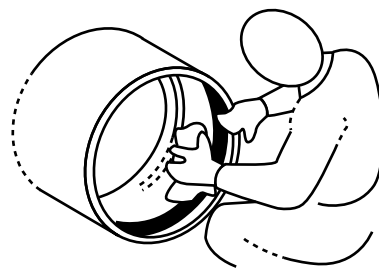

Figure 3-3 Lubricant gaskets

Step 4 Clean and Lubricate Spigots

Thoroughly clean pipe spigots to remove any dirt, grit, grease, etc. Inspect spigot sealing surface for possible damage. Apply a thin layer of lubricant to the spigots from the end of the pipe to the black alignments stripe. After lubricating, take care to keep the coupling and spigots clean (Figure 3-4).

! Caution: It is very important to use only the correct lubricant. The supplier provides sufficient lubricant with each delivery of couplings. If for some reason you run out, please contact the supplier for additional supply or advice on alternative lubricants. Never use a petroleum based lubricant.

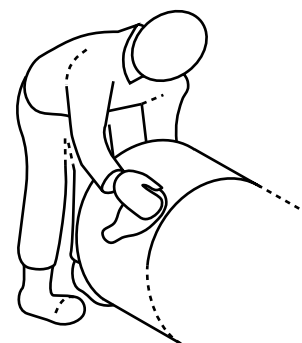

Figure 3-4 Cleaning spigot

Joining

If the coupling is not pre-mounted it should be mounted on the pipe in a clean, dry place before the pipes are joined. This is accomplished by placing a clamp or a sling around the pipe at a distance of 1 to 2 m from the spigot on to which the coupling will be mounted. Make sure the pipe spigot is resting at least 100 mm above the ground surface to keep away from dirt. Push the coupling on to the pipe spigot end manually and place a 100 x 50 mm timber across the coupling. Use two come-along jacks connected between the timber and the clamp and pull the coupling into position i.e. until the coupling is aligned with the "home line" (see Figure 3-5). See chapter „Gap between Pipe Spigots“ in the right column for appropriate distance to the homeline. The following steps (5 to 7) apply to joining pipes using clamps or slings and "come-along jacks". Other techniques may also be used providing the general objectives outlined here are met. In particular, insertion of the spigot ends of the pipe should be limited to the homeline and any damage to the pipe and coupling avoided.

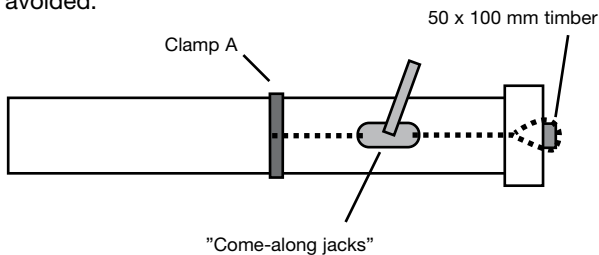

Figure 3-5 Mounting of coupling on pipe

Step 5 Pipe Placement

The pipe with the coupling mounted is aligned on the pipe supports.

Step 6 Fixing of Clamps

Clamp (or sling) A is fixed anywhere on the first pipe or left in position from the previous joint. Fix Clamp (or sling) B on the pipe to be connected in a convenient position (Figure 3-6).

! Note: Clamp contact with the pipe shall be padded or otherwise protected to prevent damage to the pipe and to have high friction resistance with the pipe surface. If clamps are not available, nylon slings or rope may be used, but care must be taken in the alignment of the coupling.

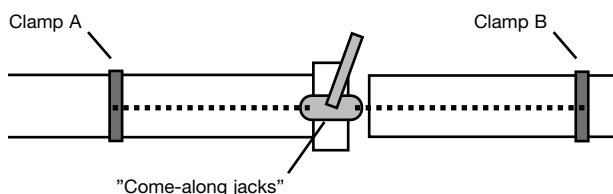

Figure 3-6 Pipe joining using clamps

Step 7 Join Coupling

Come-along jacks are placed one on each side of the pipe and connected to the clamps. The pipe is pulled into position into the coupling. For appropriate gap between pipe ends see chapter "Gap Between Pipe Spigots" below. Clamp A is then moved onto the next pipe to be joined.

The approximate mounting force can be calculated as follows:

$$\text{Mounting forces in tons} = (\text{DN in mm} / 1000) \times 2$$

Gap Between Pipe Spigots

Aboveground pipelines will, if exposed to direct sunlight, be warmed up by the sun and expand. This applies especially for pipelines that are empty during the installation phase or for other reasons. To avoid excessive loads on pipes and pipe supports, the pipes must be joined with sufficient gap between spigots so as to avoid contact between the spigots even at the highest possible temperatures.

The adequate gap depends on the highest possible temperature rise that can be expected for the pipe and the length of pipe between anchors that can expand into the joint. For evaluation of minimum gap between spigots, a linear coefficient of thermal expansion of max. $28 \times 10^{-6}/^{\circ}\text{C}$ can be assumed for FLOWTITE pipes in the longitudinal direction. The minimum gap can be calculated as:

$$g_{\min} = (T_{\max} - T_{\text{inst}})L \times 28 \times 10^{-6}$$

where:

T_{\max} is the maximum expected pipe temperature in $^{\circ}\text{C}$.

T_{inst} is the pipe installation temperature in $^{\circ}\text{C}$.

L is the pipe length (anchor to anchor) expanding into the joint in mm.

A gap of 25 mm between spigots will be sufficient for most installations with pipe length up to and including 12 m. The gap between pipe ends should not exceed 30 mm.

For joints with angular deflection, the gap will vary around the circumference of the pipe. In such cases the minimum gap shall be within the limitations stated above while the maximum gap should under no circumstances exceed 60 mm. The gap requirements above apply for non-pressurized pipe.

Angular Deflection at Double Bell Couplings

The angular deflection at coupling joints must be limited in order to avoid excessive loads on pipeline and supports. Pressurized aboveground FLOWTITE pipes shall be installed in straight alignment while changes in line direction are achieved by bends and thrust restraints. Unintended angular deflection at coupling joints for pipes installed in straight alignment, shall not exceed 20% of the values in **Table 3-1**. Slight changes in line direction of low pressure pipelines less or equal PN6, can however, on special occasions, be achieved by angular deflections at joints. Such installations require special consideration and it must be assured that supports at joints with angular deflection have adequate thrust restraint.

! Note: The pipe supplier shall be consulted prior to installing pipes with angular deflection.

Nominal Pipe Diameter	Nominal Angle of Deflection	Nominal Joint/Coupling Offset
(mm)	(°)	(mm)
300	3	17
350	3	20
400	3	22
450	3	25
500	3	28
600	2	21
700	2	25
800	2	29
900	2	32
1000	1	18
1100	1	20
1200	1	21
1400	1	25
1600	1	29
1800	1	32
2000	0.5	18
2200	0.5	20
2400	0.5	21
2600	0.5	23
2800	0.5	25
3000	0.5	27

Table 3-1 Angular Deflection at Double Bell Coupling Joint (See Figure 3-6)

If pipes are installed with angular deflection at joints, it must be ensured that the total angular deflection does not exceed the nominal values given in **Table 3-1**. In that regard, normal installation tolerances and the load induced angular deflections, explained below, have to be accounted for. The angular deflection of a joint shall be distributed on both sides of the coupling, see **Figure 3-8**. The coupling to pipe angular deflection shall under no circumstances exceed the values given in **Table 3-1**. For aboveground pipelines, the loads acting on the pipeline will create angular deflection at joints although the pipes are installed in straight alignment. Normally most of the loads are gravitational forces causing angular deflection in the vertical convex direction, see **Figure 3-7**. The magnitude of this angular deflection depends on the pipe diameter and class as well as the supporting and loading conditions. For pipes installed in two cradles, with maximum support spacing and loading according to **Table 4-5**, this load induced angular deflection can on special occasions reach 70% of the nominal values given in **Table 3-1**. For pipes installed in multiple cradles, according to **Table 4-6**, this effect is limited to maximum 30% of the values from **Table 3-1**.

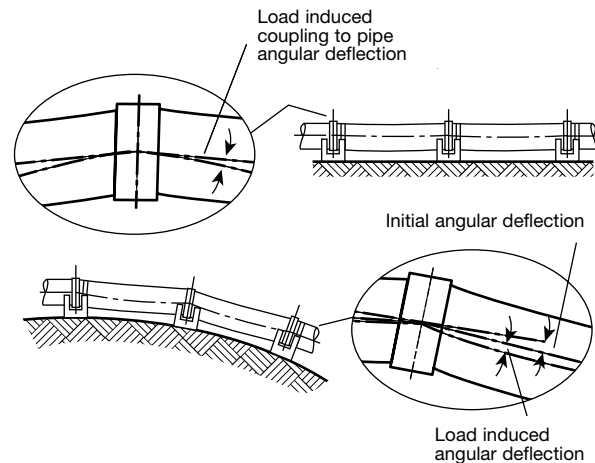

Note: Angles are exaggerated for illustration

Figure 3-7 Pipe deflection

FLOWTITE Sewer Coupling (FSC)

A gasket is used for the FSC, which is pre-equipped by the supplier and fixed to the coupling groove. With that the steps, described in **Section 3.1** – cleaning of the grooves and installing of the gasket – can be dropped. All other working instructions and user data are identical with the steps – mentioned in **Section 3.1** – for the FLOWTITE Pressure Coupling.

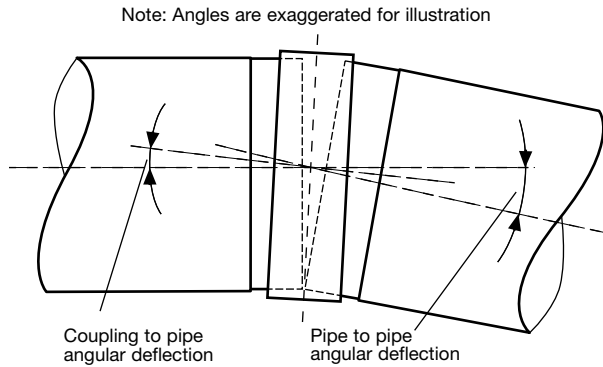

Figure 3-8 Angular deflection

Anchoring of Pipes

Joined pipes shall not be left unanchored. Extreme temperature variations, e.g. caused by exposure to sunlight, will result in expansions and contractions in the pipes. If a string of several pipes is exposed to such conditions prior to anchoring of the individual pipes, couplings and pipes can be forced out of position.

Checking the Installed Joint

The quality of the joining operation is of utmost importance for the performance of the pipeline. Therefore a thorough checking of the installed joint is strongly recommended. Angular deflection, coupling position, joint misalignment and gap between pipe ends should be checked. The quality of the joints should be checked as soon as possible after joining as the joint might be difficult to correct when the coupling gaskets have settled. The quality of the joint should also be checked after filling and pressurizing the pipeline, see [Section 5](#).

! Note: The installed joint should be checked at normal temperatures. High and/or uneven pipe temperatures, caused by e.g. direct sunlight, will affect the results of the check.

Angular Deflection

Both pipe to pipe and coupling to pipe angular deflection should be checked, see [Figure 3-8](#). The angular deflection is easiest checked with reference to the alignment stripes, see [Figures 3-9](#) and [3-10](#). The pipe to pipe angular deflection is for a given pipe dimension, approximately proportional to the joint offset which is the difference between the maximum and minimum distance between the alignment stripes, $d_{max} - d_{min}$, see [Figure 3-11](#).

The coupling to pipe angular deflection is in a similar way approximately proportional to the coupling offset, $a_{max} - a_{min}$ for the left side and $b_{max} - b_{min}$ for the right side, see [Figure 3-9](#). The pipe to pipe and the coupling to pipe angular deflection can then be calculated based on the measured offset and the pipe's outer diameter. Alternatively, the angular deflection can be estimated by proportioning the nominal joint/coupling offset given in [Table 3-1](#).

Angular Deflection = Nominal Angular Deflection x (Measured Offset/Nominal Offset)

For allowable angular deflection see the section on Angular Deflection of Double Bell Couplings.

Coupling Position

The coupling shall be mounted centric relative to the

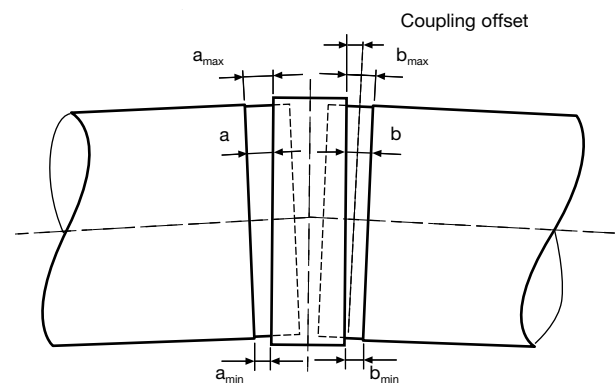

Figure 3-9 Measuring of coupling angular offset and position

joint within a tolerance of ± 10 mm. The coupling position is easiest measured with reference to the alignment stripes. The average distance from the alignment stripe to the coupling edge is estimated for both sides of the coupling as:

$$a_{ave} = (a_{max} - a_{min})/2$$

$$b_{ave} = (b_{max} - b_{min})/2$$

See [Figure 3-9](#) for definitions. The coupling position relative to the centre of the joint is then calculated as:

$$-10 \text{ mm} \leq (a_{ave} - b_{ave})/2 \leq 10 \text{ mm}$$

Joint misalignment

Maximum misalignment of pipe ends shall not exceed the less of 0,5% of pipe diameter or 3 mm. The misalignment can be measured with two identical knotted rulers pressed against the pipe at both sides of the coupling, see **Figure 3-10**. If the depth of the machined spigot surface is different for the two pipes, the measured misalignment shall be corrected accordingly. For pipes 700 mm and larger the misalignment can be measured with a ruler from the inside of the pipe, see **Figure 3-10**.

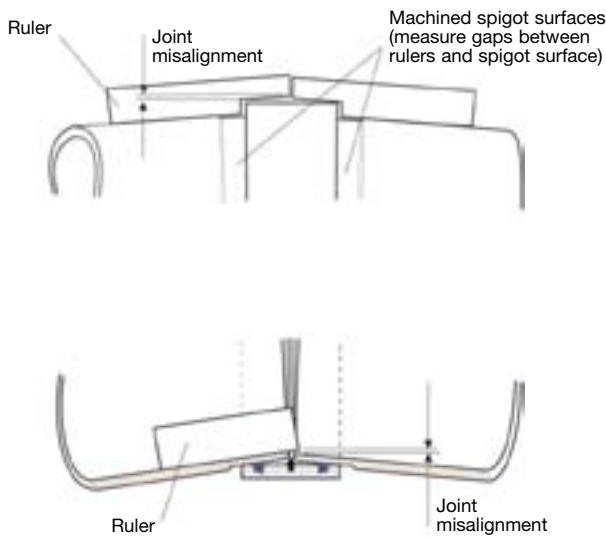

Figure 3-10 Misalignment

Gap Between Pipe Spigots

The gap between pipe spigots is easiest checked by measuring the distance between the alignment stripes, see **Figure 3-11**. The gap, g , is then calculated as:
 $g = d - 2s$

The distance from the pipe end to the alignment stripes, s , can be found in the pipe specification or measured prior to installation. For pipes DN700 and larger the gap can be measured directly from the inside of the pipe. For joints with angular deflection, both maximum and minimum gap shall be measured. For requirements for gap between pipe spigots, see the section on Gap Between Pipe Spigots.

Adjusting Joints

The joint shall be adjusted if any of the checks described in the preceding section falls outside the specified limits. The necessary adjustments of coupling or pipe position shall be made carefully, avoiding concentrated loads or impact loads that might damage pipe or coupling.

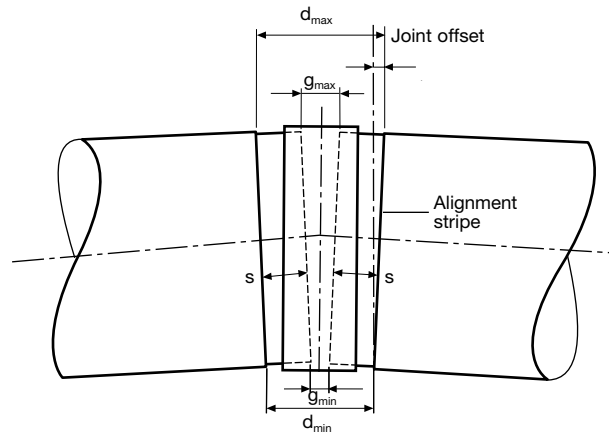

Figure 3-11 Gap between pipe ends

3.2 Other Joining Methods

Flexible Steel Couplings

(Straub, TeeKay, Arpol, etc. – see **Figure 3-12**)

When connecting FLOWTITE pipe to other pipe materials with different outside diameters, flexible steel couplings are one of the preferred joining methods. These couplings consist of a steel mantle with an interior rubber sealing sleeve. They may also be used to join FLOWTITE pipe sections together, for example in a repair or for closure.

Three grades are commonly available:

- 1 Coated steel mantle
- 2 Stainless steel mantle
- 3 Hot dip galvanized steel mantle

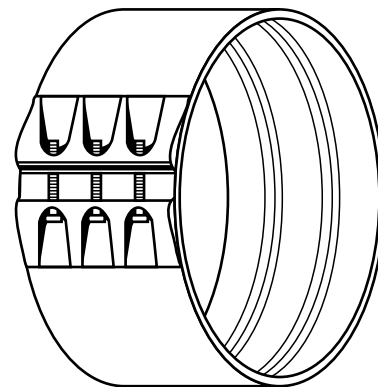

Figure 3-12 Flexible steel coupling

Control of the bolting torque of flexible steel couplings is important. Do not over torque as this may over stress the bolts or the pipe. Follow the coupling manufacturer's recommended assembly instructions, but with the pipe supplier's recommended bolt torque limits.

! Note: Flexible steel couplings must be ordered with the manufacturer's insert for containment of the gasket.

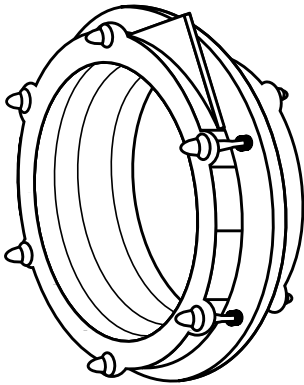

Figure 3–13 Dual bolt mechanical coupling

Mechanical Steel Couplings

(Viking Johnson, Helden, Kamflex, etc. see **Figure 3–13**)

Mechanical couplings have been used successfully to join pipes of different materials and diametres, and to adapt to flange outlets. There is a wide variation in the design of these couplings, including bolt size, number of bolts and gasket design. Large variations also exist in the diameter tolerance of other materials, which often results in higher bolt torque than necessary in order to achieve a tight seal on the FLOWTITE side.

Consequently, we cannot recommend the general use of mechanical couplings with FLOWTITE pipe. If a mechanical coupling is used to join FLOWTITE to another pipe material then only mechanical couplings with a dual independent bolting system should be used (**Figure 3–13**). This allows for the independent tightening of the FLOWTITE side, which typically requires less torque than recommended by the coupling manufacturer.

It is advised that the local FLOWTITE pipe supplier be consulted when mechanical couplings are contemplated for use on a project. Be prepared to present information on the specific design (brand and model). The pipe supplier can then advise under what conditions, if any, this design might be suitable for use with FLOWTITE.

Corrosion Protection

Regardless of the corrosion protection applied to the steel mantle, the balance of the coupling needs to be corrosion protected as well. Typically this involves the application of a shrink fit polyethylene sleeve over the installed coupling.

GRP Adapters

The FLOWTITE coupling can be used to join FLOWTITE pipe to other materials with the same outside diameter (**Table 7–1**) for non-pressure applications. For higher pressures consult the manufacturer.

Special GRP adaptors or stepped couplings can be made to connect GRP pipe with other materials or different diametres. Consult the manufacturer.

3.3 Flanged Joints

Contact Moulded

Loose ring and fixed flanges are also available for joining to other pipe materials, valves or accessories. GRP flanges should be joined according to the following procedure: (**Figure 3–14**)

- 1** Thoroughly clean the flange face and the O-ring groove.
- 2** Ensure the sealing gasket is clean and undamaged.
- 3** Position sealing gasket in groove.
- 4** Align flanges to be joined.
- 5** Insert bolts, washers and nuts. All hardware must be clean and lubricated to avoid incorrect tightening. Washers must be used on all GRP flanges.
- 6** Using a torque wrench, tighten all bolts to 35 Nm torque, [20 Nm for small diameter DN 250] following standard flange bolt tightening sequences.
- 7** Repeat this procedure, raising the bolt torque to 70 Nm, [35 Nm for small diameter] or until the flanges touch at their inside edges. Do not exceed this torque. To do so may cause permanent damage to GRP flanges.
- 8** Check bolt torques one hour later and adjust if necessary to 70 Nm (35 Nm for small diameter).

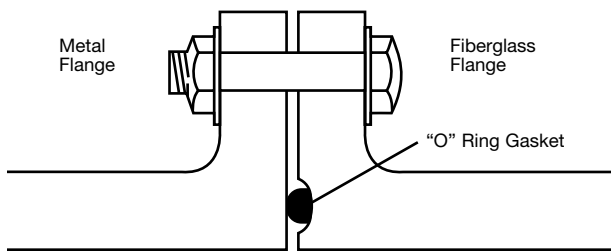

Figure 3-14 Flanged Joint

Loose Ring Flanges

FLOWTITE pipe can also be supplied with loose ring (van Stone) flanges. The loose ring can be rotated to easily align with the bolt holes in the mating flange.

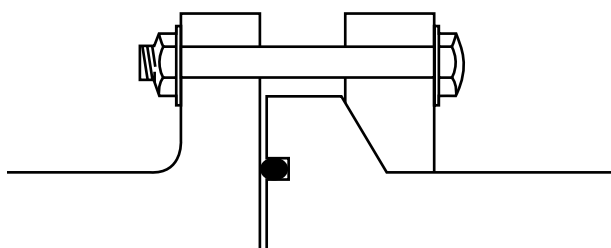

Figure 3-15 Loose ring flange with O-ring gasket

The loose ring flange can be manufactured for two types of gasket sealing using

- 1 an "O"-ring seal (groove required in flange face, see **Figure 3-15**) and
- 2 an "O"-ring profile gasket with steel ring for flat flange surfaces (no groove required) as shown in **Figure 3-16**.

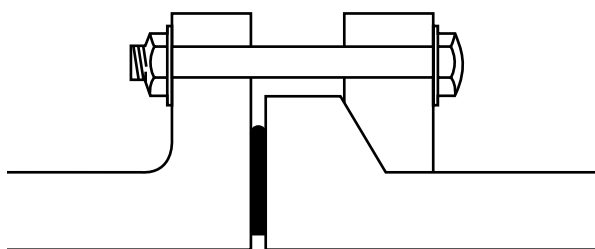

Figure 3-16 Loose ring flange with O-ring profile gasket with steel ring

The joining procedure for both types of loose ring flanges is identical and is described below.

- 1 Thoroughly clean the flange face to be joined and where applicable the "O"-ring groove.
- 2 Ensure the gasket to be used is clean and undamaged. Do not use defective gaskets.
- 3 Position the gasket onto the flange face. For the "O" ring seal, ensure that the gasket is pushed firmly into the "O"-ring groove. It is recommended that the "O"-ring be secured with small strips of tape or adhesive.
- 4 Align flanges to be jointed.
- 5 Insert bolts, washers and nuts. All hardware must be clean and lubricated to avoid incorrect tightening. It is important that the mating surface between the bolt head/washers and backing ring plate are well lubricated to avoid excessive torque build up.
- 6 Use a torque wrench to tighten all bolts to the required torque settings in **Table 3-2** following standard flange bolt tightening sequences.
- 7 Check bolt torques one hour later and adjust if necessary to the set bolt torque.

Type of Gasket	PN	Maximum torque Nm*)
"O"-ring	6	50 x Pipe OD (in m)
"O"-ring	10	100 x Pipe OD (in m)
"O"-ring	16, 20	125 x Pipe OD (in m)
"O"-ring	25	200 x Pipe OD (in m)
"O"-profile with integral ring	6	45 x Pipe OD (in m)
"O"-profile with integral ring	10	75 x Pipe OD (in m)
"O"-profile with integral ring	16, 20	90 x Pipe OD (in m)
"O"-profile with integral ring	25	135 x Pipe OD (in m)

Table 3-2 Torque settings for loose ring flanges

! **Note:** When connecting two GRP flanges made with an "O"-ring gasket, only one flange shall have a gasket groove in the face.

4 Installation of Aboveground Pipes

4.1 Introduction

This section of the manual describes the requirements for installation of FLOWTITE pipes above ground. It applies for pipes joined by non-restrained couplings as the double bell FLOWTITE coupling or flexible steel couplings. When designing an aboveground pipe installation it is important to be aware of the forces that act on the pipe system and particularly for high pressure systems. When a component in a pressurized pipeline has a change in cross-sectional area or direction, a resultant force is induced. All such components, as e.g. bends, reducers, tees, wyes or valves, must be anchored to withstand these loads. For a buried pipeline, adequate resistance is provided by the pipe embedment and thrust blocks. Such resistance may not be provided at the supports of an aboveground pipeline. Care must be exercised to minimize misalignments and all components must be properly supported to ensure the stability of the pipeline.

4.2 Supporting of Pipes

FLOWTITE pipes are joined with couplings that do not restrain longitudinal expansion and contraction of the pipes. To minimize the loads induced in pipes and supports, the supports shall not restrain longitudinal expansion of the pipes. It is, however, essential that the pipe movements are guided and controlled in such a way that all pipe sections are stable and that the coupling's ability to accept longitudinal movement is not exceeded. The non-restrained couplings are flexible and it is very important that the stability of every pipe component is ensured by the supports. Every pipe shall therefore be supported by at least two cradles and anchored at one of these. The remaining cradle(s) shall be designed as guide(s), allowing longitudinal expansion of the pipe but restraining lateral movements. For pipes supported in more than two cradles, the cradle closest to the middle of the pipe should be used as an anchor. The anchors shall be located with regular spacing in order to ensure even distribution of longitudinal pipe expansion on the joints. However, the distance between two anchors shall not exceed 12 m. **Figure 4-1** shows typical supporting of pipes.

! **Note:** When a pipe is supported on more than two supports, the pipe supports shall be in straight alignment. Maximum deviation from straight alignment is 0,1% of the span length. Supports shall limit displacement of pipes, in all of the restrained directions, to 0,5% of the diameter or 6 mm, whichever is less.

! **Note:** It is important that support displacement does not result in misalignment of pipe ends in joints. Maximum allowable pipe end misalignment is the lesser of 0,5% of the diameter or 3 mm

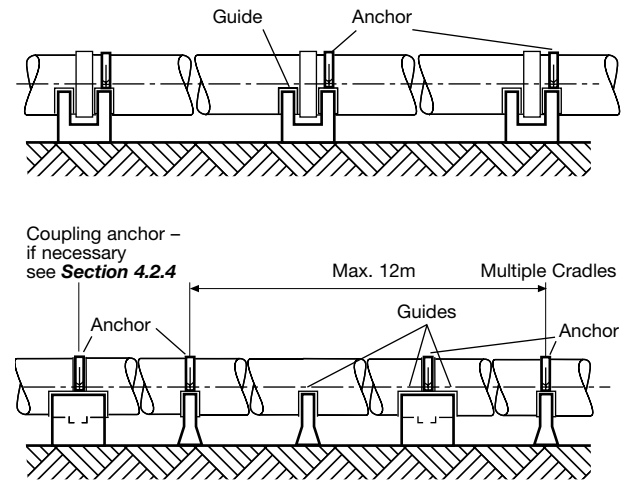

Figure 4-1 FLOWTITE pipes.
Typical support arrangement

Pipes shall be installed in straight alignment in order to avoid reaction forces caused by angular deflection at joints. See **Section 3** [➔](#).

The pipes must be supported adjacent to the joints in order to ensure the stability of the couplings. Maximum distance from the centreline of the joint to centerline of a support shall be 250 mm for pipes with DN500 or less and the lesser of 0,5 x DN or 500 mm for pipes with DN600 or larger (**Figure 4-1**).

4.2.1 Support Design

Any excessive point or line loading shall be avoided when pipes are installed aboveground. Aboveground FLOWTITE pipes shall therefore be supported in cradles. Normally the cradles are made from concrete or steel. The cradles shall have a supporting angle of 150°. The diameter of the finished cradle with cradle liners shall be 0,5% larger than the outer diameter of the non-pressurized pipe (**Figure 4-2**). The cradles shall have:

- a minimum width of 150 mm for all pipes with $DN \leq 1000$ mm,
- a minimum width of 200 mm for pipes between DN1100 mm and DN2000 mm and
- a minimum width of 250 mm for pipes with $DN > 2000$ mm

The inside of the cradles shall be covered with a 5 mm thick cradle liner to avoid direct contact between pipe and cradle. Liners must be made from materials that are resistant to the actual environment. High friction liners shall be applied at anchors while low friction liners shall be applied at guides. See **Section 4.2.3** [➔](#), Anchor design and **Section 4.2.4** [➔](#), Guide design for liner specifications. **Figure 4-2** shows the cradle design. The pipe supports are designed as anchors or guides. Anchors are designed to restrain pipe movement. Guides are designed to allow the pipe to expand in the longitudinal direction but restrain it from any lateral displacement.

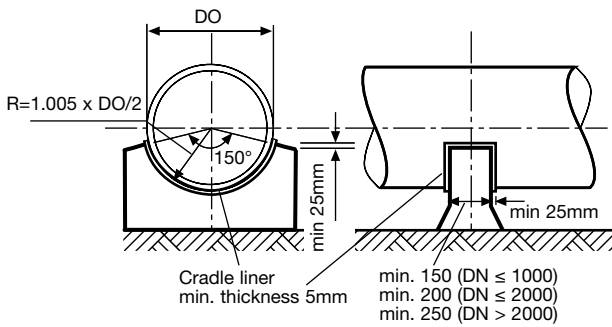

Figure 4-2 Cradle design

4.2.2 Loads on Supports

The supports shall be rigid and designed to withstand the actual loads caused by:

- External and environmental loads
- Weight of pipe and fluid
- Reaction forces caused by internal pressure
- Friction induced in couplings and against guides in case of temperature and/or pressure variations.

It is the responsibility of the owner’s engineer to determine design loads for the supports. Frictional force between pipe and guide shall be determined based on total compression between pipe and cradle and the frictional coefficient between the pipe material and the cradle liner. For the cradle liners suggested in **Section 4.2.4**, Guide design, the frictional coefficient can be assumed to be 0.3. **Table 4-1** provides approximate axial coupling frictional forces that should be considered in the design of support cradles. These loads result from contraction and elongation of pipe during operation and frictional resistance in the gasketed joint. **Table 4-1** is based on the assumption of simultaneous expansions and contractions of the neighboring pipes. If non-simultaneous expansions and contractions can be expected, contact the pipe supplier for adequate axial forces.

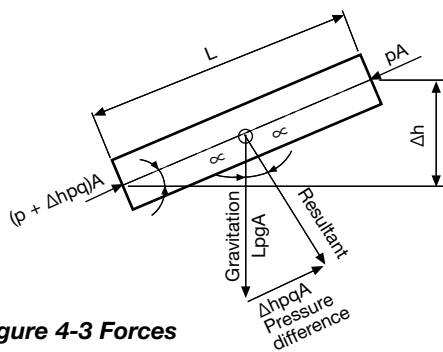

Figure 4-3 Forces

DN	FS*	FP**			
	Gravity	PN 1	PN 6	PN 10	PN 16
300	4	5	5	6	7
350	4	5	6	6	8
400	4	5	6	7	8
450	4	6	6	7	9
500	4	6	7	8	10
600	5	7	8	9	11
700	5	7	8	10	12
800	5	8	9	11	14
900	6	8	10	12	15
1000	6	9	11	13	16
1100	7	9	12	14	17
1200	7	10	12	15	19
1300	7	11	13	16	20
1400	8	11	14	17	21
1500	8	12	15	18	23
1600	9	12	15	19	24
1700	9	13	16	20	25
1800	9	14	17	21	27
1900	10	14	18	22	28
2000	10	15	18	23	29
2100	10	15	19	24	
2200	11	16	20	25	
2300	11	16	21	26	
2400	12	17	22	27	
2500		18	22		
2600		18	23		
2700		19	24		
2800		19	25		
2900		20	25		
3000		21	26		

* Sewer Pipes for High Pressure Cleaning

** Standard Pipes

For detailed information please contact your local supplier.

Table 4-1 SN5000 FLOWTITE pipes. Axial loads due to frictional resistance in joints (kN)

! **Note:** The reaction forces, caused by dead weight of water, act perpendicular to the pipe. For pipe installations with steep slope this results in a significant horizontal load on the pipe foundations. It is a common error to regard the reaction from water as vertical since it is a gravitational force, see **Figure 4-3**.

! **Note:** The water column within a pressurized pipeline often carries a considerable compressive load. It is important to ensure that the supporting structures are stiff enough to avoid column buckling of the pipeline.

4.2.3 Anchor Design

Anchors shall be designed as cradles with high friction cradle liners and a pretensioned steel clamp pressing the pipe against the cradle. The pretension of the clamp shall be sufficient to prevent the pipe from moving in the cradle.

! **Note:** GRP pipes have higher design strain than steel. The steel clamp shall therefore be designed with spring elements to compensate for this difference. The spring elements shall be designed such that sufficient strap tension can be ensured at low pressure or no pressure without overloading the strap or the pipe in situations involving high working pressure. The design of the steel clamp and the spring elements depends on the properties of the pipe and the loading conditions. **Figure 4-4** shows typical design of steel clamp with bracket and disk springs.

The key dimensions for seven different standard clamp designs are shown in **Table 4-3**.

Nominal Pipe Diameter [mm]	Recommended Bracket Height h [mm]
$300 \leq DN \leq 400$	150
$450 \leq DN \leq 600$	200
$700 \leq DN \leq 900$	250
$1000 \leq DN \leq 1300$	300
$1400 \leq DN \leq 2000$	400
$2100 \leq DN \leq 3000$	500

Table 4-2 Bracket Height

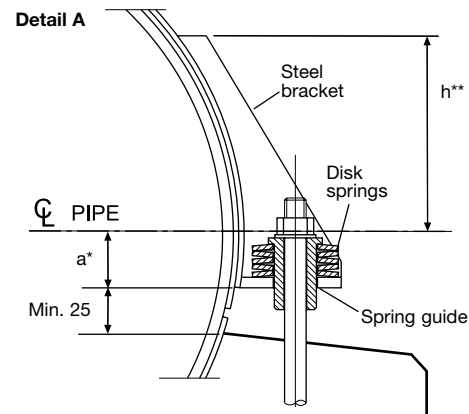
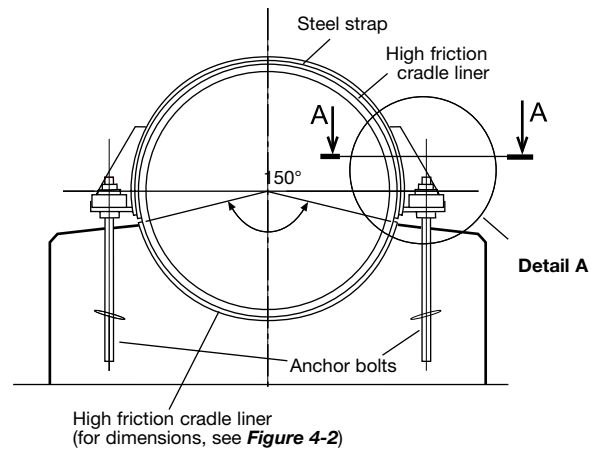

Section A-A

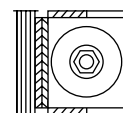

* For $DN \geq 600$ $a = 50$ mm
For $DN < 600$ $a = DN/8-25$

** The height of the bracket shall be chosen such that the stability of the bracket is ensured. A line drawn tangent to the pipe at the upper edge of the bracket must cross the centerline of the anchorbolt well above the baseplate of the bracket. See **Table 4-2**.

Figure 4-4 Clamp design

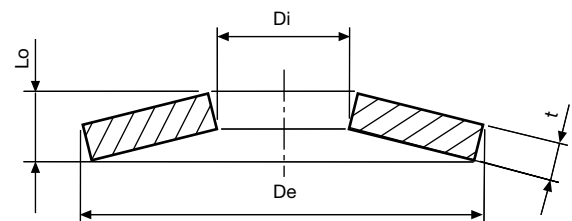

Figure 4-5 Disk spring dimensions

Clamp Design	I	II	III	IV	V	VI	VII
Design load	2 x 12 kN	2 x 22 kN	2 x 36 kN	2 x 50 kN	2 x 67 kN	2 x 95 kN	2 x 140 kN
Steel strap**	100 x 5mm	100 x 5mm	120 x 5mm	120 x 5mm	140 x 6mm	140 x 8mm	180 x 10mm
Cradle liner*	100 x 5mm	100 x 5mm	120 x 5mm	120 x 5mm	140 x 5mm	140 x 5mm	180 x 5mm
Disk springs							
External diameter, D _e	80	80	100	100	125	125	150
Internal diameter, D _i	36	36	51	51	64	61	81
Thickness, t	3	4	5	6	7	8	10
Length, l ₀	5.7	6.2	7.8	8.2	10.0	10.9	13.0
Max. allowable single spring compression	2.03mm	1.65mm	2.10mm	1.65mm	2.25mm	2.18mm	2.25mm
Anchor bolts**	M20	M20	M25	M25	M30	M30	M36

* The clamping specification in Table 4.3 is based on high friction cradle liner with friction factor against pipe and cradle min. 0.7 as i. e. 60-70 Shore A Thermoplastic Polyurethane.

** Dimensions are based on the following minimum steel qualities:
Steel strap: ISO 630, Fe 360 (DIN 17100, St. 37)
Anchor bolt: ISO 630, Fe 510 (DIN 17100, St. 52)

Table 4-3 Key dimensions for standard clamp designs

Table 4-3 shows clamp design, number of spring elements, number of disk springs in spring element and precompression of spring elements for SN5000 FLOWTITE pipes. **Table 4-3** is worked out for FLOWTITE pipes on two supports as shown in **Figure 4-8** and maximum pipe length according to **Table 4-4**. **Table 4-3** is worked out based on the following loading conditions:

- Maximum working pressure = Nominal pressure
- Maximum surge pressure = 1.4 x Nominal pressure
- Maximum external load on pipe = 2.5 kN/m² on projected area
- Maximum slope of pipe 10°, 20° and 30°, see table heading →
- Joint axial load According to **Table 4-1**
- Minimum temperature, empty pipe 50°C lower than installation temperature
- Maximum temperature, empty pipe 50°C higher than installation temperature
- Minimum temperature, filled pipe 20°C lower than installation temperature
- Maximum temperature, filled pipe 20°C higher than installation temperature

The clamp design is specified in **Table 4-3** with the following nomenclature: N x n/c where

- N is the number of spring elements
- N=1 means spring element on one side of the clamp
- N=2 means spring elements on both sides of the clamp
- n is the number of disk springs in each spring element
- c is the required precompression of each spring element in mm. The values apply for non-pressurized, pipes. The applicable clamp design from **Table 4-2** is shown in the last column of the table. The clamp design applies for the area of the table marked with lines.

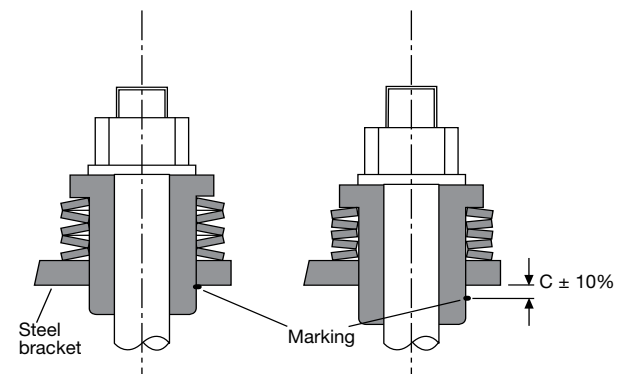

Figure 4-6 Adjusting precompression of disk springs

DN	FS*	FP**				Clamp Design
	Gravity***	PN 1***	PN 6	PN 10	PN 16	
300	4	6	1 x 3/2.5	1 x 3/2.4	1 x 3/2.4	I
350	4	7	1 x 3/2.7	1 x 3/2.7	1 x 3/2.7	
400	5	7	1 x 3/3.0	1 x 3/2.9	1 x 3/3.0	
450	5	8	1 x 3/3.3	1 x 3/3.1	1 x 5/4.2	
500	6	8	1 x 3/3.5	1 x 3/3.3	1 x 5/4.4	
600	6	9	1 x 5/5.0	1 x 5/4.9	1 x 7/7.6	
700	7	10	1 x 5/5.5	1 x 7/7.5	1 x 7/7.6	
800	8	11	1 x 5/3.1	1 x 5/3.0	1 x 7/4.0	
900	9	12	1 x 5/3.4	2 x 3/1.9	2 x 5/3.1	
1000	9	13	2 x 3/2.2	2 x 5/3.3	2 x 5/3.4	
1100	10	14	2 x 5/3.7	2 x 5/3.6	2 x 5/3.7	II
1200	11	16	2 x 5/4.0	2 x 5/3.9	2 x 7/5.4	
1300	12	17	2 x 5/4.3	2 x 7/5.7	2 x 7/5.8	
1400	13	18	2 x 7/6.2	2 x 7/6.1	2 x 5/3.5	
1500	14	19	2 x 7/6.6	2 x 5/3.8	2 x 5/3.8	
1600	15	20	2 x 5/4.1	2 x 5/4.0	2 x 5/4.0	
1700	16	21	2 x 5/4.4	2 x 5/4.3	2 x 7/5.8	
1800	17	22	2 x 5/4.6	2 x 7/6.1	2 x 7/6.2	
1900	18	23	2 x 5/4.9	2 x 7/6.4	2 x 7/6.5	
2000	19	24	2 x 7/6.9	2 x 7/6.8	2 x 9/8.7	
2100	20	25	2 x 7/7.3	2 x 9/9.0	III	
2200	20	26	2 x 7/7.6	2 x 9/9.4		
2300	21	27	2 x 9/10.0	2 x 9/9.9		
2400	22	28	2 x 9/10.4	2 x 11/12.5		
2500		29	2 x 9/10.9	IV		
2600		30	2 x 11/13.9			
2700		30	2 x 9/7.6			
2800		34	2 x 7/6.4			
2900		35	2 x 7/6.6			
3000		36	2 x 7/6.9			
						V

**Table 4-3a SN 5000 FLOWTITE Pipes on Two Supports.
Clamping of Pipes on Anchors. Maximum Slope 10°**

* Sewer Pipes for High Pressure Cleaning

** Standard Pipes

*** Disk springs not required. Clamp pretension given in kN
For detailed information please contact your local supplier.

Table 4-3 applies also for pipes supported in more than two cradles, provided that the cradle closest to the middle of the pipe is used as the anchor (**Figure 4-1**). For other installation and loading conditions, contact pipe supplier. The specified precompression of spring elements is achieved by marking the spring guide

relative to the clamp after having finger tightened the anchor nut. The marking shall be made as permanent as possible in order to enable checks at a later stage. Then the nut shall be tightened until the mark on the guide has been displaced to the specified precompression +/- 10% (**Figure 4-6**).

Note: The tension in the steel strap tends to be uneven due to the friction against the protective liner. The tension shall be distributed by tapping the steel strap with a rubber mallet while the anchor nuts are being tightened.

DN	FS*	FP**				Clamp Design
	Gravity	PN 1***	PN 6	PN 10	PN 16	
300	1 x 3/1.6	6	1 x 3/2.5	1 x 3/2.4	1 x 3/2.4	I
350	1 x 3/1.8	7	1 x 3/2.7	1 x 3/2.7	1 x 3/2.7	
400	1 x 3/2.0	8	1 x 3/3.0	1 x 5/4.8	1 x 3/2.7	
450	1 x 3/2.2	9	1 x 3/3.3	1 x 3/2.9	1 x 5/4.7	
500	1 x 3/2.4	10	1 x 5/5.8	1 x 5/5.1	1 x 5/5.1	
600	1 x 3/2.8	11	1 x 5/6.0	1 x 7/8.2	1 x 7/8.3	
700	1 x 3/3.2	12	1 x 7/9.5	1 x 5/3.3	1 x 7/4.5	
800	1 x 3/3.7	14	1 x 5/3.9	1 x 7/5.1	1 x 7/4.5	
900	1 x 3/4.2	16	1 x 7/5.9	2 x 5/4.1	2 x 5/4.1	
1000	2 x 3/4.4	18	2 x 5/4.6	2 x 5/4.6	2 x 5/2.2	III
1100	2 x 3/5.0	20	2 x 5/5.2	2 x 7/7.0	2 x 5/4.0	
1200	2 x 3/2.7	22	2 x 3/2.8	2 x 5/4.4	2 x 5/4.4	
1300	2 x 3/3.0	24	2 x 5/4.9	2 x 5/4.8	2 x 5/4.9	
1400	2 x 3/3.2	26	2 x 5/5.4	2 x 5/5.3	2 x 7/7.3	
1500	2 x 3/3.5	28	2 x 5/5.9	2 x 7/7.8	2 x 7/8.0	
1600	2 x 3/3.8	30	2 x 7/8.6	2 x 7/8.5	2 x 7/5.2	IV
1700	2 x 5/6.7	32	2 x 7/9.3	2 x 7/5.6	2 x 9/7.2	
1800	2 x 5/7.2	34	2 x 7/6.2	2 x 9/7.6	2 x 9/7.7	
1900	2 x 3/3.8	36	2 x 9/8.2	2 x 8/8.2	2 x 7/6.4	V
2000	2 x 3/4.0	40	2 x 9/8.9	2 x 7/6.8	2 x 7/6.8	
2100	2 x 3/4.3	42	2 x 5/5.5	2 x 7/7.3		
2200	2 x 3/4.6	45	2 x 7/7.9	2 x 7/7.7		
2300	2 x 3/5.0	47	2 x 7/8.4	2 x 9/10.3		
2400	2 x 3/8.5	52	2 x 7/8.9	2 x 9/11.0		
2500		55	2 x 9/11.9			VI
2600		57	2 x 7/7.5			
2700		60	2 x 7/7.9			
2800		63	2 x 9/10.4			
2900		66	2 x 9/10.9			
3000		74	2 x 11/13.3			

**Table 4-3b SN 5000 FLOWTITE Pipes on Two Supports.
Clamping of Pipes on Anchors. Maximum Slope 20°**

* Sewer Pipes for High Pressure Cleaning

** Standard Pipes

*** Disk springs not required. Clamp pretension given in kN
For detailed information please contact your local supplier.

DN	FS*	FP**				Clamp Design
	Gravity	PN 1	PN 6	PN 10	PN 16	
300	1 x 3/1.9	1 x 3/2.6	1 x 3/2.5	1 x 3/2.4	1 x 3/2.4	I
350	1 x 3/2.1	1 x 3/2.9	1 x 3/2.7	1 x 3/2.7	1 x 3/2.7	
400	1 x 3/2.4	1 x 3/3.2	1 x 3/3.0	1 x 3/2.9	1 x 5/4.8	
450	1 x 3/2.6	1 x 3/3.6	1 x 3/3.3	1 x 5/5.2	1 x 5/5.2	
500	1 x 3/2.9	1 x 3/4.0	1 x 5/5.8	1 x 5/5.8	1 x 7/8.0	
600	1 x 3/3.5	1 x 3/4.6	1 x 7/9.6	2 x 5/6.7	2 x 5/6.8	
700	1 x 3/4.1	1 x 3/5.4	2 x 5/8.0	1 x 7/5.3	1 x 7/5.3	
800	1 x 3/4.7	1 x 3/3.1	1 x 7/6.3	2 x 5/4.4	2 x 5/4.4	II
900	1 x 5/8.6	1 x 3/3.6	2 x 5/5.1	2 x 5/5.0	2 x 7/7.0	
1000	2 x 3/2.8	2 x 3/3.8	2 x 7/7.9	2 x 5/4.4	2 x 5/4.5	III
1100	2 x 3/3.2	2 x 3/4.3	2 x 5/5.1	2 x 5/5.0	2 x 5/5.1	
1200	2 x 3/3.6	2 x 5/7.7	2 x 5/5.7	2 x 5/5.6	2 x 7/7.9	
1300	2 x 3/4.0	2 x 3/4.1	2 x 5/6.4	2 x 7/8.7	2 x 7/8.8	
1400	2 x 5/7.1	2 x 3/4.5	2 x 7/9.7	2 x 7/6.8	2 x 7/6.9	
1500	2 x 3/3.8	2 x 3/4.9	2 x 7/6.5	2 x 7/6.8	2 x 9/8.2	IV
1600	2 x 3/4.2	2 x 3/5.4	2 x 7/7.1	2 x 9/8.8	2 x 5/5.0	
1700	2 x 3/4.6	2 x 3/9.4	2 x 9/9.7	2 x 5/5.4	2 x 7/7.5	V
1800	2 x 3/5.0	2 x 3/3.9	2 x 5/6.0	2 x 7/8.0	2 x 7/8.1	
1900	2 x 5/8.6	2 x 3/4.1	2 x 5/6.5	2 x 7/8.6	2 x 9/11.1	
2000	2 x 3/3.6	2 x 5/7.1	2 x 7/9.5	2 x 9/11.8	2 x 7/6.7	VI
2100	2 x 3/3.9	2 x 3/4.7	2 x 9/12.9	2 x 7/7.2		
2200	2 x 5/6.6	2 x 3/5.0	2 x 9/13.8	2 x 7/7.7		
2300	2 x 5/7.1	2 x 3/5.3	2 x 7/8.4	2 x 9/10.4		
2400	2 x 3/4.7	2 x 3/5.7	2 x 7/9.0	2 x 9/11.1		
2500		2 x 3/9.7	2 x 9/12.0			
2600		2 x 3/4.6	2 x 11/15.8			
2700		2 x 3/4.9	2 x 9/10.1			
2800		2 x 3/5.1	2 x 9/10.7			
2900		2 x 3/5.4	2 x 9/11.4			VII
3000		2 x 3/9.2	2 x 11/14.4			

* Sewer Pipes for High Pressure Cleaning

** Standard Pipes

**Table 4-3c SN 5000 FLOWTITE Pipes on Two Supports.
Clamping of Pipes on Anchors. Maximum Slope 30°**

4.2.4 Guide Design

Guides shall be designed as cradles with low friction cradle liners (**Figure 4-2**). The friction factor between FLOWTITE pipes and the liner shall be less than 0.3. This requirement is fulfilled by e.g. ultrahigh-molecular polyethylene and polytetrafluorethylene liners. It must be ensured that the liner material is resistant to the actual environment. The cradle liner shall be permanently attached to the guide cradle to ensure its stability. In many situations, the weight of pipe and fluid is sufficient to ensure the lateral stability of a pipe in a guide. The ends of short high pressure pipes can, however, lift up from guides as a result of an unfavourable combination of high pressure forces in the fluid and pipe to coupling angular deflection. The need for securing of pipe ends depends on the combination of internal pressure, pipe to coupling angular deflection and the supporting conditions. Vertical convex angular pipe to coupling deflection and internal pressure creates a force that tends to lift the pipe end (**Figure 4-7**).

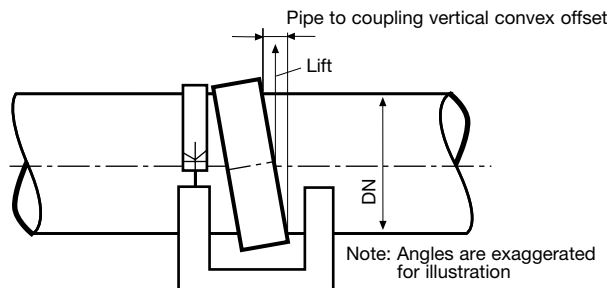

Figure 4-7 Stability of pipe ends on guides

If such a lifting force can become large enough to lift up pipe end, the pipe ends must be secured. The securing of pipe ends is best achieved by clamping the coupling to the foundation supporting the joint. For in situ cast concrete supports, see **Figure 4-8**. The clamps used for anchoring of pipes, see **Section 4.2.3**, can be used for clamping of couplings to foundations. See **Section 4.2.3** for selection and mounting of clamps.

Nominal Pipe Diameter (mm)	Vertical Convex Angle of Deflection (°)	PN 1			PN 6			PN 10			PN 16		
		Slope			Slope			Slope			Slope		
		10°	20°	30°	10°	20°	30°	10°	20°	30°	10°	20°	30°
300 ≤ DN < 500	3	1.2	1.3	1.4	n.a.	n.a.	n.a.	n.a.	n.a.	n.a.	n.a.	n.a.	n.a.
500 < DN ≤ 900	2	0.8	0.8	0.9	4.8	5.0	5.4	n.a.	n.a.	n.a.	n.a.	n.a.	n.a.
900 < DN ≤ 1800	1	0.4	0.4	0.5	2.4	2.5	2.7	4.0	4.2	4.5	6.4	6.7	7.2
DN > 1800	0.5	0.2	0.2	0.2	1.2	1.3	1.4	2.0	2.1	2.3	3.2	3.3	3.6

Table 4-4a Water Filled Pipes on Two Cradles. Minimum Pipe Length for Stable Ends

n.a. = not applicable clamp couplings
For PN > 16 please contact your local supplier

Nominal Pipe Diameter (mm)	Vertical Convex Angle of Deflection (°)	PN 1			PN 6			PN 10			PN 16		
		Slope			Slope			Slope			Slope		
		10°	20°	30°	10°	20°	30°	10°	20°	30°	10°	20°	30°
300 ≤ DN < 500	3	1.6	1.7	1.8	n.a.	n.a.	n.a.	n.a.	n.a.	n.a.	n.a.	n.a.	n.a.
500 < DN ≤ 900	2	1.1	1.1	1.2	n.a.	n.a.	n.a.	n.a.	n.a.	n.a.	n.a.	n.a.	n.a.
900 < DN ≤ 1800	1	0.5	0.6	0.6	3.2	3.3	3.6	5.3	5.6	6.0	n.a.	n.a.	n.a.
DN > 1800	0.5	0.3	0.3	0.3	1.6	1.7	1.8	2.7	2.8	3.0	4.2	4.4	4.8

Table 4-4b Water Filled Pipes on Multiple Cradles. Minimum Support Spacing for Stable Ends

n.a. = not applicable clamp couplings
For PN > 16 please contact your local supplier

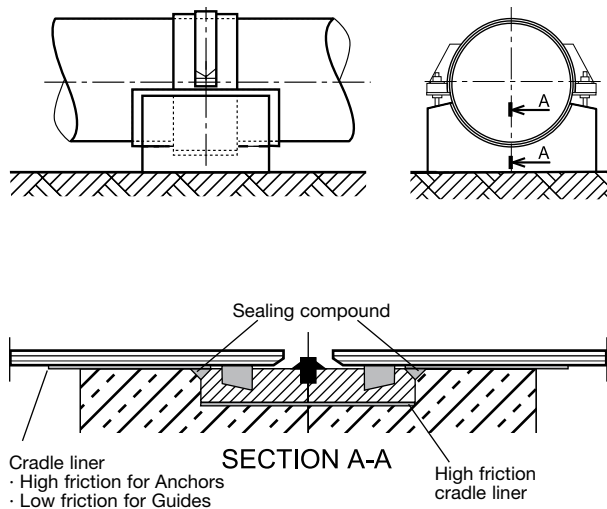

Figure 4-8 Anchoring of couplings to concrete supports

The need for securing pipe ends depends on the angular deflection at joints, the pressure in the pipes and the supporting conditions. Both pipe to pipe and coupling to pipe angular deflection must be considered. **Tables 4-4a** and **4-4b** show the minimum support spacing needed to ensure sufficient reaction from the dead weight of pipe and fluid to counteract the lifting force created. A vertical convex angular deflection corresponding to the values given in **Table 3-1** is assumed together with working pressure equal to the nominal pressure of the pipe, surge pressure equal to 1.4 x nominal pressure and maximum field test pressure as given in **Table 5-1**. The tables are worked out for pipe installations in different slopes.

4.3 Maximum Supporting Spacing

The maximum support spacing is determined based on the properties of the pipe and the loading conditions. Stresses in the pipe wall must be kept within allowable limits and excessive pipe deflections must be avoided. **Table 4-5** on the next page shows maximum pipe lengths for FLOWTITE pipes supported on two cradles. The table is based on the following loading conditions and pipe support as shown in **Figure 4-9**.

- Density of fluid = 1000 kg/m³
- Maximum working pressure = Nominal pressure
- Maximum field test pressure According to **Table 5-1**
- Maximum surge pressure = 1.4 x nominal
- Maximum external load on pipe = 2.5 kN/m² proj. area

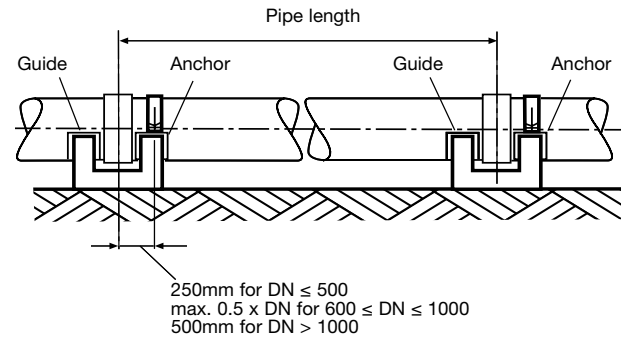

Figure 4-9 Pipes supported on two cradles

Table 4-6 on the next page shows maximum support spacing for FLOWTITE pipes supported on three or more cradles. Maximum standard FLOWTITE pipe length is 12 m and the table covers only support spacing less than 6 m. The table is worked out based on the following loading conditions and supporting as shown in **Figure 4-10**.

- Density of fluid = 1000 kg/m³
- Maximum working pressure = Nominal pressure
- Maximum field test pressure according to **Table 5-1**
- Maximum surge pressure = 1.4 x nominal
- Maximum external load on pipe = 2.5 kN/m² proj. area

For other loading conditions, please consult the supplier.

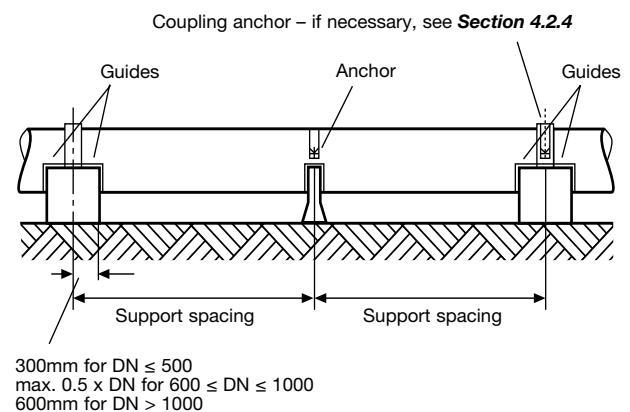

Figure 4-10 Pipes supported in multiple cradles

4.4 Negative Pressure

The allowable negative pressure (vacuum) is -0.5 bar for SN 5000 and -1.0 bar for SN 10000.

	FS*	FP**			
DN	Gravity	PN 1	PN 6	PN 10	PN 16
300	3.4	3.5	3.2	3.0	2.6
350	3.7	3.8	3.5	3.4	2.9
400	4.0	4.1	3.8	3.7	3.3
450	4.1	4.4	4.1	4.0	3.7
500	4.3	4.7	4.4	4.3	4.1
600	4.6	5.2	4.9	4.9	4.7
700	4.9	5.8	5.5	5.4	5.4
800	5.2	6.3	6.0	5.9	6.1
900	5.4	6.8	6.5	6.4	6.6
1000	5.6	7.2	7.0	6.9	7.2
1100	5.9	7.6	7.5	7.5	7.7
1200	6.2	8.0	7.8	7.8	8.1
1300	6.4	8.3	8.0	8.0	8.4
1400	6.6	8.5	8.3	8.3	8.6
1500	6.8	8.8	8.5	8.5	8.9
1600	7.0	9.0	8.7	8.8	9.2
1700	7.2	9.1	8.9	9.0	9.4
1800	7.3	9.3	9.1	9.2	9.7
1900	7.5	9.5	9.3	9.4	9.9
2000	7.7	9.7	9.5	9.6	10.1
2100	7.8	9.8	9.6	9.8	
2200	8.0	10.0	9.8	9.9	
2300	8.2	10.1	10.0	10.1	
2400	8.3	10.3	10.1	10.3	
2500		10.4	10.3		
2600		10.6	10.4		
2700		10.7	10.6		
2800		10.8	10.7		
2900		11.0	10.8		
3000		11.1	11.0		

* Sewer Pipes for High Pressure Cleaning
 ** Standard Pipes

For detailed information please contact your local supplier.

**Table 4-5 SN 5000 Maximum Pipe Length
 on Two Cradles [m]**

	FS*	FP**			
DN	Gravity	PN 1	PN 6	PN 10	PN 16
300	3.4	4.0	3.9	3.0	2.6
350	3.6	4.3	4.2	3.5	3.0
400	3.8	4.5	4.5	3.9	3.3
450	3.9	4.8	4.7	4.3	3.7
500	4.1	5.0	5.0	4.8	4.1
600	4.3	5.4	5.4	5.5	4.7
700	4.6	5.9	5.9	6.0	5.4
800	4.9	≥6.0	≥6.0	≥6.0	≥6.0
900	5.1	≥6.0	≥6.0	≥6.0	≥6.0
1000	5.4	≥6.0	≥6.0	≥6.0	≥6.0
1100	5.6	≥6.0	≥6.0	≥6.0	≥6.0
1200	5.9	≥6.0	≥6.0	≥6.0	≥6.0
≥1300	≥6.0	≥6.0	≥6.0	≥6.0	≥6.0

* Sewer Pipes for High Pressure Cleaning

** Standard Pipes

For detailed information please contact your local supplier.

**Table 4-6 SN 5000 Maximum Support Spacing,
 Multiple Cradle Installations [m]**

5 Checking the installed pipe

5.1 Field Hydrotesting

Some job specifications require the completed pipe installation to be hydrostatically tested prior to acceptance and service. This is good practice as it can permit early detection and correction of installation flaws, damaged products, etc. If a field hydrotest is specified, it must be done regularly as installation proceeds. In addition to routine care, normal precautions and typical procedures used in this work, the following suggestions should be noted:

- 1 Preparation Prior to Test – Inspect the completed installation to assure that all work has been finished properly. Of critical importance are:
 - Joints assembled correctly
 - System restraints (i.e. thrust blocks, and other anchors) in place and properly cured
 - Flange bolting torqued per instructions
 - Valves and pumps anchored.
 See **Section 5.2** →.
- 2 Filling the Line with Water – Open valves and vents, so that all air is expelled from the line during filling and avoid pressure surges. When the pipeline has been filled it shall be inspected. See **Section 5.3** →.
- 3 Pressurize the line slowly. Considerable energy is stored in a pipe line under pressure and this power should be respected.
- 4 Insure the gauge location will read the highest line pressure or adjust accordingly. Locations lower in the line will have higher pressure due to additional head.
- 5 Insure the maximum test pressure is not exceeded (See **Table 5-1** →). This may be dangerous and result in damage to the pipe system.
- 6 If after a brief period for stabilization the line does not hold constant pressure, insure that thermal effect (a temperature change) or entrapped air is not the cause. If the pipe is determined to be leaking and the location is not readily apparent, the following

methods may aid discovery of the problem source:

- Check flange and valve areas
- Check line tap locations
- Check joints for leakage

5.2 Inspection Prior to Filling of Pipe

The pipe shall not be filled with water until the complete installation has been inspected in order to assure that all work has been finished properly. Special attention shall be paid to the following aspects:

1 Joints

The joints shall be checked as described in **Section 3** → in regard to:

1. Angular deflection
2. Coupling position
3. Joint alignment and
4. The gap between the pipe ends

The coupling position relative to both of the pipes shall be marked at 4 points around the circumference (**Figure 5-1**) as reference for later checks. It shall be checked that the gaskets are correctly seated and that the gap between pipe spigot and coupling sleeve is free of concrete or other foreign inclusions.

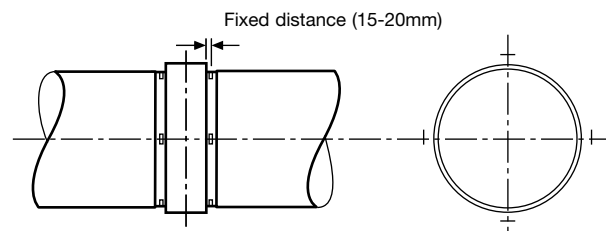

Figure 5-1 Marking coupling position

2 Supports

Check that the cradle gives even and continuous support to the pipe and that the cradle diameter is $0,5 \pm 0,25\%$ larger than the pipe. Check the support angle to be $150 \pm 5^\circ$. For pipes supported on more than two supports, the alignment of pipe supports shall be checked. Maximum deviation from straight alignment is 0,1% of the span length. Check that the cradle liner is in place between the pipe and the cradle and ensure that there is no direct contact between cradle and pipe. Check that there is no concrete or other foreign inclusion between the pipe and the cradle liner. Check that there are high-friction liners at anchors and low-friction liners at guides. Check the structural integrity of the supports. Mark the position of the pipe relative to the anchors, as reference for later inspection.

3 Clamps

Check that the liner is correctly positioned between the clamp and the pipe or coupling. Check the number and compression of disk springs against the specification.

Pressure Class	Maximum Field Test Pressure
100kPa	150kPa
600kPa	900kPa
1000kPa	1500kPa
1600kPa	2400kPa

For Higher Pressure please contact us.

Table 5-1 Maximum Field Test Pressure

Check structural integrity of the steel clamp and anchor bolts. Check that the steel clamp is positioned perpendicular to the pipe axis.

4 Pipes

Inspect the pipes to ensure that they have not been damaged in the installation phase. Check the support spacing against specifications.

5 Other

Check thrust blocks, anchors, valve pumps, etc.

5.3 Inspection of Filled Pipeline Prior to Pressurizing

When the pipe has been filled with water, it shall be inspected prior to pressurizing. Special attention shall be paid to the following aspects:

1 Joints

Inspect the joints for any sign of leakage. Check couplings' movement relative to the marks made prior to filling the pipe.

! **Note:** The weight of fluid in the pipe will cause rotation of pipe ends (**Figure 5-2**).

Check the coupling to pipe angular offset, see **Section 3** →.

If a coupling has moved, its new position relative to both of the pipes shall be marked at 4 points around the circumference (**Figure 5-1**). If there is any sign of coupling movement in excess of what can be explained by load induced pipe end rotation, the position of the coupling shall be checked. The stability of the coupling and the pipe end supports shall also be verified in an appropriate way. If there is a reason to believe that supports might have settled due to the added weight, the pipe end misalignment shall be checked. Pipe end misalignment shall be less than 0,5% of pipe diameter and 3 mm.

2 Supports

Check the structural integrity and stability of the supports. Check if the added weight has caused settlement or deflection of supports.

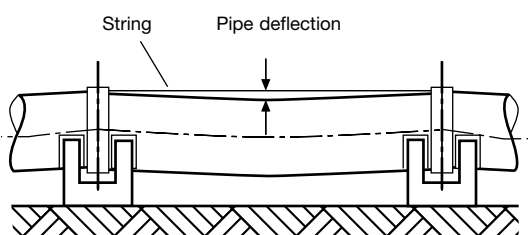

Figure 5-2 Pipe deflection

3 Pipes

Measure the maximum deflection of the pipes for each pipe span. The pipe deflection can be measured by using a tensioned string as a reference (**Figure 5-2**). If the maximum deflection at any pipe span exceeds the span length divided by 300, the pipe supplier shall be contacted prior to pressurizing the pipe.

5.4 Inspection of Pressurized Pipelines

When the pipe has been pressurized, the pipe shall be inspected. Special attention shall be paid to the following aspects:

1 Joints

Inspect the joints for any sign of leakage. It shall be checked if the couplings have moved relative to the marks made prior to pressurizing of the pipe.

! **Note:** In addition to the Poisson's effect, the pressure increase in the pipe can cause slight rotation of pipe ends (**Figure 5-2**).

Check the coupling to pipe angular offset, see **Section 3** →. If there is any sign of coupling movement in excess of what can be explained by the Poisson's effect and pressure induced pipe end rotation, the stability of the coupling and the pipe end supports shall be verified in an appropriate way.

2 Supports

Check the structural integrity and stability of the supports. Check if the pressure increase has caused settlement or deflection of supports. Use the marks to check if the pipe has moved relative to the anchors. If a pipe has moved relative to anchor, the pipe shall be depressurized and the anchoring revised prior to repressurizing.

3 Clamps

Check the compression of disk springs and ensure that the compression does not exceed the maximum allowable spring compression (**Table 4-2**). The spring compression can be measured using the marks on the spring guide (**Figure 4-6**). Check structural integrity of the steel clamp and anchor bolts.

4 Pipes

Measure and record the maximum deflection of the pipes for each pipe span. The pipe deflection can be measured by using a tensioned string as a reference (**Figure 5-2**).

If the maximum deflection at any pipe span has increased by more than 50% compared to the deflection measured for filled and unpressurized pipe, the pipe shall be depressurized immediately and the pipe supplier shall be contacted.

Check the pipes for dark areas or weeping.

6 Thrust Restraints, Concrete Encasement and Connections to Rigid Structures

6.1 Thrust Restraints

When the pipeline is pressurized, unbalanced thrust forces occur at bends, reducers, tees, wyes, bulkheads and other changes in line direction. These forces must be restrained in some manner to prevent joint separation. Determination of need and design, as well as the level of steel reinforcement of concrete structures, is the responsibility of the owner's engineer. FLOWTITE fittings are designed to withstand the full internal pressure, while the concrete structure shall support its shape and transfer the load. As the expansion of the pressurized fittings is typically greater than the tensile strength of the concrete would carry, steel reinforcement to control crack widths should be considered. The following conditions also apply:

Thrust Blocks

Thrust blocks must limit the displacement of the fitting relative to the adjacent pipe to preserve the leak tightness of the FLOWTITE coupling joint. The resulting angular deflection shall be less than the values indicated in **Table 3-1**.

For more details of pipe installation and system layout see clauses **6.2** and **6.3** →.

For operating pressures above 10 bar (PN>10) the block must completely surround the fitting. For lower pressures special fittings can be supplied that allow for partial embedding. The block must be built on firm foundation.

! Note: It is important that support settlement does not result in misalignment of pipe ends in joints. Maximum allowable pipe end misalignment is the lesser of 0,5% of the diameter or 3mm.

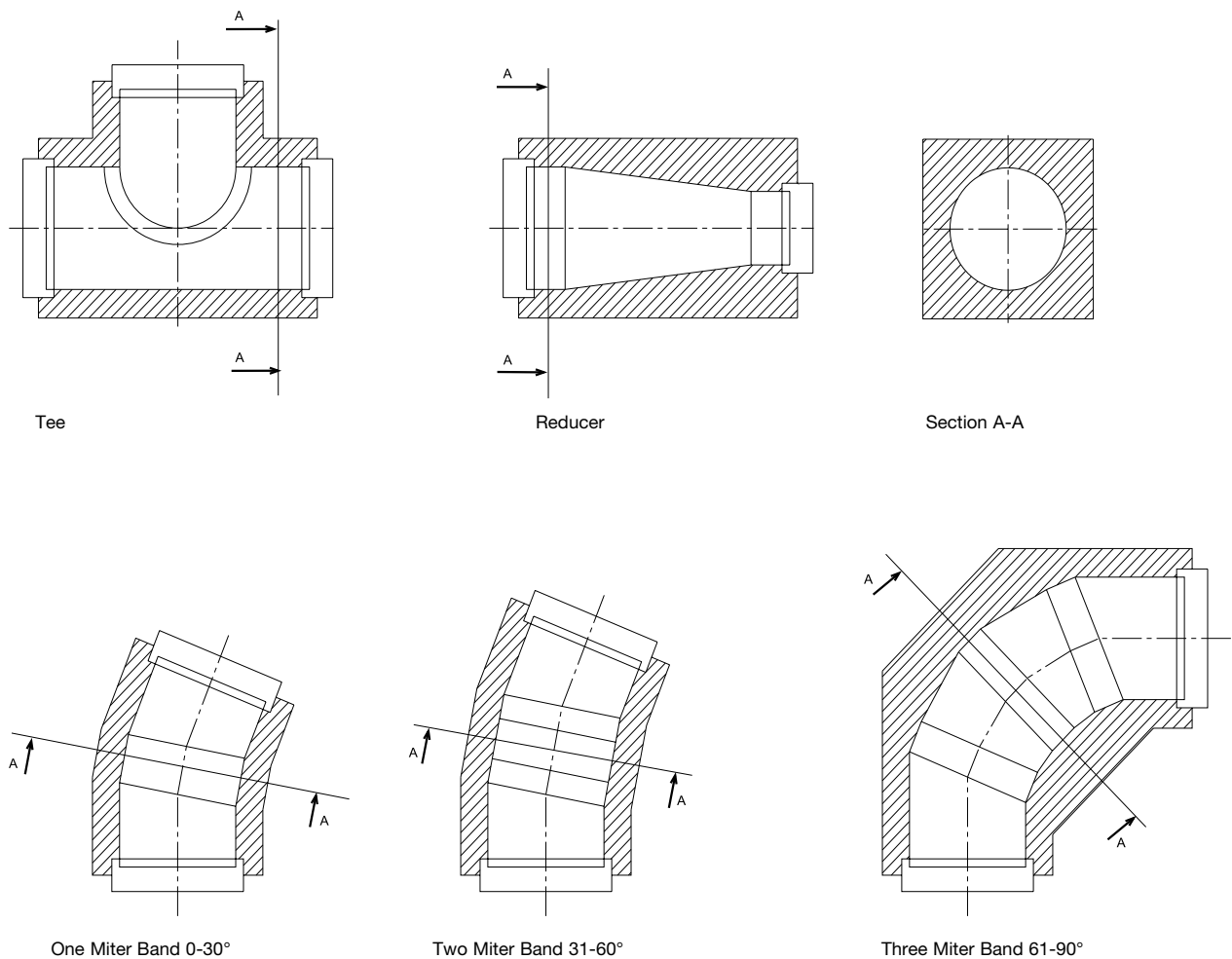

Figure 6-1 Thrust blocks

Thrust blocks are required when the line pressure exceeds 1 bar (100 kPa) for all fittings where unbalanced thrust occurs, such as: bends, reducers, bulkheads, blind flanges, tees, wyes and bifurcations.

Concentric manways (blind flange tees), drains and air vents, which do not generate unbalanced thrust in operation, do not require encasement, but do require thrust resistant branches and fittings.

! Note: The thrust block shapes shown are typical for illustration. The exact shape will be dependent on design and project requirement.

Valves

Valves must be sufficiently anchored to absorb the pressure thrust. More details on valves and chambers are provided in Flowtite Installation Guide for Buried Pipes.

Nozzles

Nozzles are tee branches meeting all of the following criteria:

- 1** Nozzle diameter ≤ 300mm.
- 2** Header diameter ≥ 3 times nozzle diameter.
- !** **Note:** it is not necessary to encase nozzle connections in concrete.

6.2 Concrete Encasement

When pipes (or fittings) must be encased in concrete, such as for thrust blocks, stress blocks, or to carry unusual loads, specific additions to the installation procedures must be observed.

DN	Maximum Spacing (m)
< 400	2.5
500 – 600	4.0
700 – 900	5.0
≥ 1000	6.0

Table 6–1 Maximum Strap Spacing

Pipe Anchoring

During the pouring of the concrete, the empty pipe or fitting will experience large uplift (flotation) forces. The pipe must be restrained against movement that could be caused by these loads. This is normally accomplished by strapping over the pipe to a base slab or other anchor(s). Straps should be a flat material of minimum 25 mm width, strong enough to withstand flotation uplift forces, with a minimum of two straps per section length and with the maximum spacing between straps as shown in **Table 6–1**. The straps should be tightened to prevent pipe uplift, but not so tight that additional pipe deflection is caused (see **Figure 6–2**).

Pipe Support

The pipe should be supported in such a way that the concrete can easily flow completely around and fully underneath the pipe. Also, the supports should result in an acceptable pipe shape (less than 3% deflection and no bulges or flat areas).

Concrete Pouring

The concrete must be placed in stages allowing sufficient time between layers for the cement to set and no longer exert buoyant forces. The maximum lift heights, as a function of stiffness class, are as shown in **Table 6–2**.

Maximum lift is the maximum depth of concrete that can be poured at one time for a given nominal stiffness class.

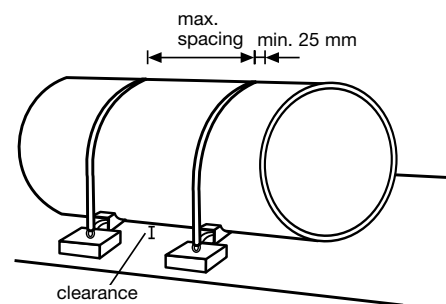

Figure 6–2 Pipe anchoring – Maximum spacing of straps see table Table 6-1

SN	Maximum lift
2500	Larger of 0.3m or DN/4
5000	Larger of 0.45m or DN/3
10000	Larger of 0.6m or DN/2

Table 6–2 Maximum Concrete Pour Lifts

6.3 Rigid Connections

When a pipe passes through a wall, is encased in concrete, meets a junction with a manhole, or is flanged to a pump, valve, or other structure, excessive bending stresses may develop in the pipe if differential movement occurs between the pipe and the rigid connection. For all rigid connections, action must be taken by the installer to minimize the development of high discontinuity stresses in the pipe. Two options are available. Alternate A (preferred) uses a coupling joint cast into the concrete-pipe interface. Alternate B wraps the pipe in rubber to ease the transition.

Alternate A

Where possible, cast a coupling joint in the concrete at the interface (**Figure 6-3**) so that the first pipe outside the concrete has complete freedom of movement (within the limits of the joint).

! Caution: When casting a coupling in concrete be sure to maintain its roundness so later joint assembly may be accomplished easily. Alternatively, make up the joint outside the encasement prior to pouring the concrete.

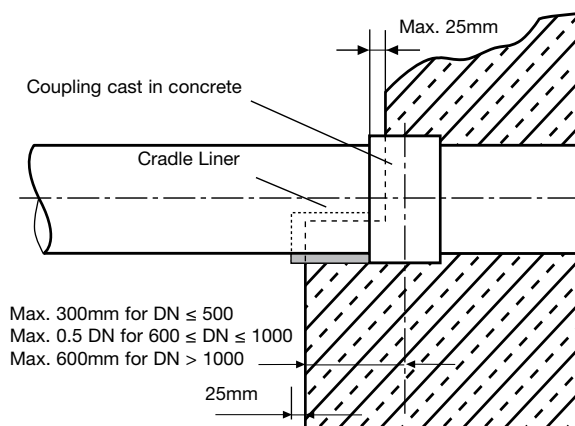

Figure 6-3 Alternate A

Alternate B

Where A is not possible, wrap (**Figure 6-4**) a band (or bands) of rubber (**Table 6-1 and Figure 6-5**) around the pipe prior to placement of any concrete such that the rubber slightly protrudes (25mm) from the concrete. Lay out the pipeline so the first completely exposed coupling joint is located as shown in **Figure 6-4**. Precautions must be taken to minimize the settlement of the reinforced concrete structure or pipe by providing an adequate foundation. Differential settlement in the pipe will cause stresses in the pipe and may cause pipe failure.

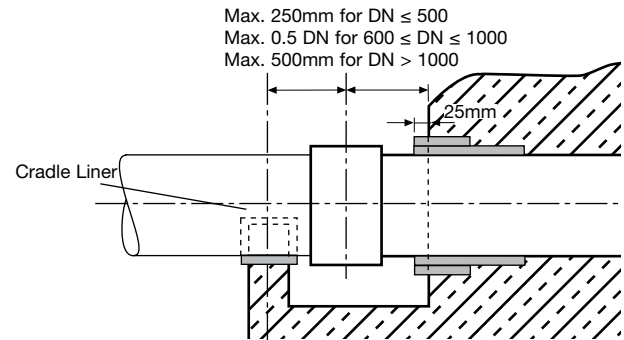

Figure 6-4 Alternate B: Rubber wraps

Diameter	Wrap configuration
300-900	A
1000-3000	C

Table 6-1 Configuration of Rubber Bands

Rubber Wrap Placement

- 1 Position as shown in **Figures 6-4** and **6-5**.
- 2 Tape all seams and edges to assure no cement can get between the rubber and the pipe or between the rubber wraps.

Type A:

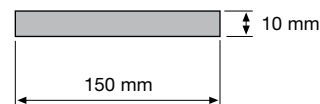

Type C:

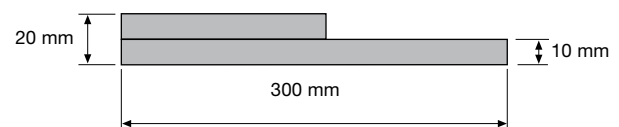

Figure 6-5 Rubber wrap configuration – Rubber shall be 50 Durometer

6.4 Casings (Tunnels)

When FLOWTITE standard pipe (unequal exterior flush) is installed in a casing the following precautions should be observed.

- 1 Pipes may be placed into the casing by pulling (drawing) or pushing (jacking). Please consult the supplier for the calculation of the maximum insertion length/-force.
 - 2 For an easy insertion and for protection from sliding damage the pipes should be equipped with plastic spacers, steel sleeves or wooden skids (as shown in **Figure 6-6** and **6-7**). These must provide sufficient height to permit clearance between the coupling joints and the casing wall.
 - 3 Installation into the casing is made considerably easier by using lubricant between the skids and the casing wall. Do not use a petroleum based lubricant as it may cause harm to some gaskets.
 - 4 The annular space between the casing and pipe may be filled with sand, gravel or cement grout. Care must be taken to not overstress or collapse the pipe during this step, particularly when grouting. Maximum grouting pressure is given in **Table 6-2**
- ! Note:** Do not wedge or brace the pipe in a manner that causes concentrated or point loads on the pipe. Consult the supplier prior to this step for advice on suitability of the chosen method.

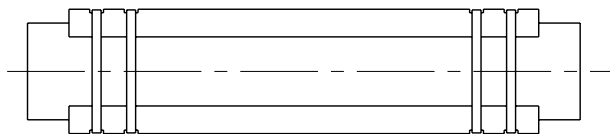

Figure 6-6 Typical skid arrangement

- ! Note:** If the annular space is not grouted and the pipe will be subjected to negative pressure, the pipe stiffness – installation combination must be sufficient to withstand the load. Consult the supplier for advice.

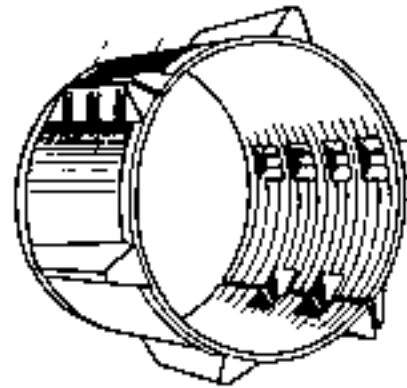

Figure 6-7 Plastic spacer unit

SN	Maximum Grout Pressure (bar)
2500	0.35
5000	0.70
10000	1.35

Table 6-2 Maximum Grouting Pressure (Pipe Invert) without Internal Supports

At the same time pipe systems with flush joint can be used.



Figure 6-8 Flush joint

7 Field Adjustments

7.1 Length Adjustment

A large majority of the pipe supplied by FLOWTITE producers has the outside diameter of the barrel of the pipe within the tolerance range of the calibrated spigot (**Table 7-1**). These pipes are often marked as Adjustment Pipe or similar. The following procedures will assist in correctly making the length adjustment:

- 1** Ensure that the pipe diameter is within the spigot tolerance range.
- 2** Determine the length required and mark a square cut on the selected pipe.
- 3** Cut the pipe at the appropriate location using a circular saw with a diamond coated blade. Use proper eye, ear and dust protection. Consult the pipe supplier for recommendations.
- 4** Clean the surface in the jointing area, sand smooth any rough spots and with a grinder bevel grind the pipe end to ease assembly (see **Figure 7-1**). No further grinding is necessary.

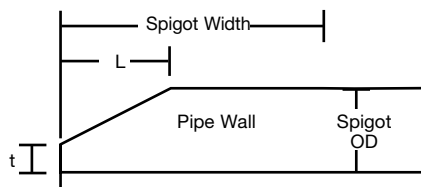

Figure 7-1 Pipe spigot and bevel dimensions definition for coupling joints

The design of the pipes does not require any sealing of the spigot ends after field cutting. If national law demands sealing, e.g. because of maintenance of industrial health and safety standards, one has to comply with it.

- !** **Note:** In relation to this it is of great importance that the interior edge of an adjustment pipe is chamfered after field cutting.

Dia- meter Series	DN (mm)	Min. OD (mm)	Max. OD (mm)	Spigot width (mm)	L (mm)
B2	300	323.4	324.5	130.0	6.0
B2	350	375.4	376.4	130.0	8.0
B2	400	426.3	427.3	130.0	10.0
B2	500	529.1	530.1	130.0	14.0
B1	600	616.0	617.0	160.0	17.0
B1	700	718.0	719.0	160.0	20.0
B1	800	820.0	821.0	160.0	20.0
B1	900	922.0	923.0	160.0	20.0
B1	1000	1024.0	1025.0	160.0	20.0
B1	1100	1126.0	1127.0	160.0	20.0
B1	1200	1228.0	1229.0	160.0	20.0
B1	1400	1432.0	1433.0	160.0	20.0
B1	1600	1636.0	1637.0	160.0	20.0
B1	1800	1840.0	1841.0	160.0	20.0
B1	2000	2044.0	2045.0	160.0	20.0
B1	2200	2248.0	2249.0	160.0	20.0
B1	2400	2452.0	2453.0	160.0	20.0
B1	2600	2656.0	2657.0	160.0	20.0
B1	2800	2860.0	2861.0	160.0	20.0
B1	3000	3064.0	3065.0	160.0	20.0

Table 7-1 Spigot Dimensions and Tolerances

- !** **Note:** Series B2 matches with Ductile Iron spigot O.D. Series B1 is GRP O.D. series. In some countries the Ductile Iron (B2) series may not be used.

7.2 Field Closures with FLOWTITE Couplings

FLOWTITE couplings can be used for field closures and repairs. The minimum length of the closure pipe should be 1 metre. The closure pipe must be supported to ensure its stability, see **Section 4.2** [→](#).

- !** **Note:** For field closure section, double the spigot width.

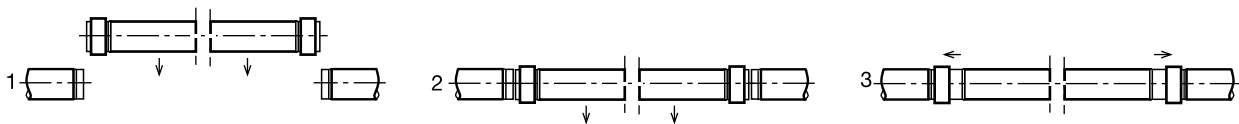

Figure 7-2 Closure section assembly

Procedure

Measure the distance between the pipe ends where you want to set in the closure pipe. The closure pipe should be 50–60 mm shorter than the measured length. The narrower the gap the easier it will be to make the closure. For minimum gap, see **Chapter 3** → Section “Gap Between Pipe Spigots”.

Pipe Selection

Choose a pipe which is within the spigot diameter tolerance. These pipes will have the required spigot outside dimension for joining along the entire pipe length. If possible choose a pipe with the outside dimension at the low end of the spigot range (see **Table 7-1**).

Pipe Preparation

Mark the pipe length required and make a cut perpendicular and square to the pipe axis with a circular saw. Use a grinding tool to make a 20 degree bevel on the pipe end and round-off the corners. Be careful that the remaining thickness on the pipe spigot end is not less than one half the pipe thickness. It is also important to have a minimum chamfer length, L, for guiding the pipe end without damaging the gasket. Follow the recommended lengths in **Table 7-1**. After bevelling, use sandpaper to remove any sharp corners on the pipe surface which may have been caused by the cutting. Smooth the spigot of any rough spots.

! Note: The spigot width must be at least equal to the coupling width. This will be twice the values shown in **Table 7-1**.

Please make sure that the surface has no grooves, and that the spigot OD is within the limits shown in **Table 7-1**.

Installation

- 1 Select two couplings, remove the centre registers, and leave the gaskets in place. Clean the couplings if necessary. The gasket groove must be free of dirt to allow unrestricted deformation of the gasket.
- 2 Lubricate carefully, including between the lips.

- 3 Lubricate also the clean spigot ends of the closure pipes with a thin continuous layer of lubricant. Do not forget the bevelled surfaces.
 - 4 Place one coupling square onto the end of the closure pipe so that the gasket is in contact around its entire circumference. Push or pull the coupling uniformly onto the closure pipe until the entire coupling is resting on the spigot end. It may be necessary to gently help the second ring over the chamfered end of the pipes. Repeat with the second coupling on the other end.
 - 5 Mark home-lines onto the adjacent pipe spigot ends to control the uniform backward movement of the coupling. The home-line’s location is calculated as follows:

$$HL = (Wc - Wg) / 2$$
 HL – homeline
 Wc – width of the coupling
 Wg – width of gap between closure pipe and adjacent pipe (measured).
 - 6 Mount and anchor the closure pipe on its supports aligned with the adjacent pipes and with equal clearance on either side. Any angle or tilt will complicate the assembling process.
 - 7 Clean the spigot ends of the adjacent pipes and lubricate with an even, thin layer. Install special tools to pull the coupling back to closing position. (consult your supplier for information about the tools). It is recommended that you pull the couplings over both sides simultaneously, keep the closure pipe centred and minimize pipe end contact. Stop pulling when the coupling’s edge touches the home-line. For man-entry size pipes, an individual inside the pipe watching the assembly process can be advantageous.
- ! Note:** After the coupling is in final position, a feeler gauge may be used to assure that gasket lips are properly oriented.

7.3 Field Closures with Non-FLOWTITE Couplings

Follow the general procedures of **Section 7.2** → except that the closure pipe will not typically need to have the special long machined spigot ends. The installation procedures for the particular coupling used must be followed (see **Section 3.2** →).

Appendix A

Approximate Weights for Pipes and Couplings

DN	FS* - Gravity				FP** - PN 1				PN 6				PN 10				PN 16			
	SN 2500	SN 5000	SN 10000	Coupling	SN 2500	SN 5000	SN 10000	Coupling	SN 2500	SN 5000	SN 10000	Coupling	SN 2500	SN 5000	SN 10000	Coupling				
mm	kg/m	kg/m	kg/m	kg	kg/m	kg/m	kg/m	kg	kg/m	kg/m	kg/m	kg	kg/m	kg/m	kg/m	kg	kg/m	kg/m	kg/m	kg
300	9.1	11.3	14.0	6.9	8.2	10.4	12.7	13.0	8.2	10.4	12.7	13.0	7.9	10.3	12.7	13.7	7.5	9.5	12.2	14.1
350	12.2	15.1	18.8	8.0	11.1	14.3	17.3	15.0	11.1	14.3	17.3	15.0	10.6	13.8	17.3	15.8	10.0	12.6	16.3	16.4
400	15.5	19.3	24.2	9.0	14.5	18.5	23.0	16.8	14.5	18.5	23.0	16.8	13.5	17.6	23.0	17.9	12.6	16.1	21.0	18.5
450	19.3	24.3	29.6	10.0	18.4	24.0	29.0	18.8	18.4	24.0	29.0	18.8	16.8	22.0	29.0	19.6	15.8	19.9	26.0	21.0
500	23.8	29.4	36.9	11.0	23.0	30.0	35.0	21.0	23.0	30.0	35.0	21.0	21.0	27.0	35.0	22.0	19.3	25.0	32.0	23.0
600	32.4	40.3	49.5	12.8	32.0	40.0	48.0	32.0	32.0	40.0	48.0	32.0	28.0	37.0	48.0	34.0	26.0	33.0	44.0	35.0
700	43.5	54.3	66.0	15.2	43.0	54.0	66.0	37.0	43.0	54.0	66.0	37.0	38.0	49.0	66.0	39.0	35.0	45.0	59.0	42.0
800	56.7	70.1	85.9	18.1	55.0	69.0	86.0	42.0	55.0	69.0	86.0	42.0	49.0	64.0	86.0	46.0	45.0	58.0	76.0	50.0
900	71.9	87.9	109.4	21.0	70.0	87.0	110.0	48.0	70.0	87.0	110.0	48.0	61.0	81.0	110.0	53.0	56.0	73.0	95.0	58.0
1000	87.8	108.0	134.3	23.8	86.0	110.0	135.0	54.0	86.0	110.0	135.0	54.0	75.0	100.0	135.0	60.0	69.0	89.0	120.0	66.0
1100	105.4	131.6	161.8	26.6	103.1	128.1	160.3	53.9	103.1	128.1	160.3	53.9	89.6	119.1	160.3	59.5	82.0	106.2	140.2	63.3
1200	126.1	155.6	192.8	29.3	125.0	155.0	195.0	66.0	125.0	155.0	195.0	66.0	110.0	145.0	195.0	74.0	98.0	130.0	170.0	81.0
1400	170.9	211.1	260.8	36.0	170.0	210.0	260.0	78.0	170.0	210.0	260.0	78.0	145.0	195.0	260.0	88.0	135.0	175.0	230.0	100.0
1600	222.7	275.0	338.9	43.1	220.0	270.0	340.0	90.0	220.0	270.0	340.0	90.0	190.0	255.0	340.0	105.0	175.0	225.0	295.0	125.0
1800	280.8	347.5	428.0	50.8	275.0	345.0	425.0	105.0	275.0	345.0	425.0	105.0	240.0	320.0	425.0	120.0	220.0	285.0	375.0	
2000	346.0	426.4	527.9	60.2	340.0	420.0	530.0	120.0	340.0	420.0	530.0	120.0	295.0	390.0	530.0	135.0				
2200	416.6	514.3	636.7	70.5	410.0	510.0	640.0	130.0	410.0	510.0	640.0	130.0	355.0	470.0	640.0	155.0				
2400	495.3	611.6	756.1	81.6	485.0	610.0	750.0	145.0	485.0	610.0	750.0	145.0	420.0	560.0	750.0	170.0				
2600	580.8	719.6	888.8	93.0	570.0	710.0	890.0	280.0	570.0	710.0	890.0	280.0								
2800	673.2	831.6	1029.6	106.0	660.0	820.0	1030.0	310.0	660.0	820.0	1030.0	310.0								
3000	769.4	951.3	1180.0	119.0	760.0	940.0	1170.0	335.0	760.0	940.0	1170.0	335.0								

* Sewer Pipes for High Pressure Cleaning
 ** Standard Pipes

- 01
- 02
- 03
- 04
- 05
- 06
- 07
- app.

Appendix B

01

02

03

04

05

06

07

app.

Joint Lubricant Requirements

Nominal Pipe Diameter (mm)	Nominal Amount of Lubricant (Kg) Required per Joint
300 to 500	0.075
600 to 800	0.10
900 to 1000	0.15
1100 to 1200	0.20
1300 to 1400	0.25
1500 to 1600	0.30
1800	0.35
2000	0.40
2200	0.45
2400	0.50
2600	0.55
2800	0.60
3000	0.65

! **Note:** Lubricants amounts are based on lubricating two gaskets and two spigot ends per joint. Factory pre-assembled coupling joints will only require half the above amounts per joint.

01

02

03

04

05

06

07

app.

This Installation Manual Above Ground is the intellectual property of Flowtite Technology AS. All rights reserved. No part of this Installation Guide may be reproduced, stored in a retrieval system, or transmitted in any form or by any means, electronic, mechanical, photocopying, recording or otherwise without the prior permission of the intellectual property owner.

Profiles for Fillings

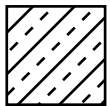

Concrete



Wood

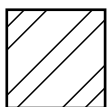

Stone

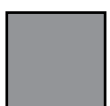

Steel

